

NISSAN

MODEL S14 SERIES

FOREWORD

This supplement contains information concerning necessary service procedures and relevant data for the model S14 series face-lift.

All information, illustrations and specifications contained in this supplement are based on the latest product information available at the time of publication. If your NISSAN model differs from the specifications contained in this supplement, consult your NISSAN distributor for information.

The right is reserved to make changes in specifications and methods at any time without notice.

QUICK REFERENCE INDEX

GENERAL INFORMATION	GI
MAINTENANCE	MA
ENGINE MECHANICAL	EM
ENGINE LUBRICATION & COOLING SYSTEMS	LC
ENGINE CONTROL SYSTEM	EC
ACCELERATOR CONTROL, FUEL & EXHAUST SYSTEMS	FE
CLUTCH	CL
MANUAL TRANSMISSION	MT
AUTOMATIC TRANSMISSION	AT
PROPELLER SHAFT & DIFFERENTIAL CARRIER	PD
FRONT AXLE & FRONT SUSPENSION	FA
REAR AXLE & REAR SUSPENSION	RA
BRAKE SYSTEM	BR
STEERING SYSTEM	ST
RESTRAINT SYSTEM	RS
BODY & TRIM	BT
HEATER & AIR CONDITIONER	HA
ELECTRICAL SYSTEM	EL
ALPHABETICAL INDEX	IDX

 NISSAN MOTOR CO., LTD.

© 1995 NISSAN MOTOR CO., LTD. Printed in Japan
Not to be reproduced in whole or in part without the prior written permission of Nissan Motor Company Ltd., Tokyo, Japan.

HOW TO USE THIS MANUAL

- ▶ This Service Manual contains the new service procedures, service data and specifications for the face-lifted model S14 series which has been in production since July, 1995.
- ▶ This Service Manual does not contain the service procedures, etc. which are the same as those for former models*. Please use this manual in conjunction with the NISSAN model S14 series Service Manual (Pub. No. SM4E-0S14G0).
- ▶ Follow the instruction below when using this manual.

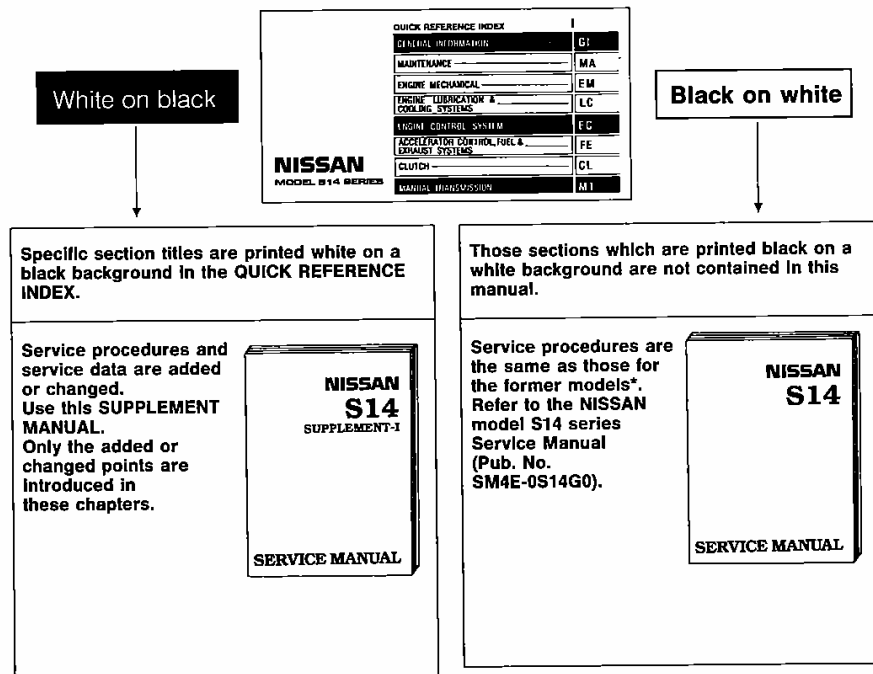

* Former models: Models before the model S14 series introduced in July, 1995.

IMPORTANT SAFETY NOTICE

The proper performance of service is essential for both the safety of the technician and the efficient functioning of the vehicle.

The service methods in this Service Manual are described in such a manner that the service may be performed safely and accurately.

Service varies with the procedures used, the skills of the technician and the tools and parts available. Accordingly, anyone using service procedures, tools or parts which are not specifically recommended by NISSAN must first be completely satisfied that neither personal safety nor the vehicle's safety will be jeopardized by the service method selected.

GENERAL INFORMATION

GI

SECTION **GI**

APPLIED FROM: For Europe: ◆ JN1GBAS14U0010001 ◆
For Australia: JN1GBAS14A0002001
For New Zealand: JN1GBAS14A0700501
Except for Europe, Australia and New Zealand: GBAS14-001001

OUTLINE OF MODIFICATIONS:

Electrical system

- NATS V2.0 (Nissan Anti-theft System Ver. 2.0)* has been adopted on models for Europe. (*Immobiliser)
- A rear fog lamp warning buzzer has been adopted on models for Europe.
- A seat belt warning lamp/buzzer has been adopted on models for Australia.

CONTENTS

PRECAUTIONS	2	CONSULT CHECKING SYSTEM	5
Precautions for NATS V2.0 (For Europe).....	2	Function and System Application.....	5
HOW TO USE THIS MANUAL	3	Checking Equipment.....	5
HOW TO READ WIRING DIAGRAMS	4	TIGHTENING TORQUE OF STANDARD BOLTS	6
Wiring Diagram Codes (Cell Codes).....	4		

PRECAUTIONS

Precautions for NATS V2.0 (For Europe)

NATS (Nissan Anti-Theft System)

NATS V2.0 will immobilize the engine if someone tries to start it without the registered key of NATS V2.0.

Both of the originally supplied ignition key IDs have been NATS registered.

The NATS security indicator is located on the instrument panel. The indicator blinks when the ignition switch is in "OFF" or "ACC" position. Therefore, NATS warns outsiders that the vehicle is equipped with the anti-theft system.

- When NATS detects trouble, the malfunction indicator lamp (MIL) blinks.

This blinking indicates that the anti-theft is not functioning, so prompt service is required.

- When servicing NATS (trouble diagnoses, system initialisation and additional registration of other NATS ignition key IDs), CONSULT hardware and CONSULT NATS software is necessary.

Regarding the procedures of NATS initialisation and NATS ignition key ID registration, refer to CONSULT operation manual, NATS V2.0.

Therefore, CONSULT NATS software (program card and operation manual) must be kept strictly confidential to maintain the integrity of the anti-theft function.

- When servicing NATS V2.0 (trouble diagnoses, system initialisation and additional registration of other NATS ignition key IDs), it may be necessary to re-register original key identification. Therefore, be sure to receive all keys from vehicle owner.

A maximum of four key IDs can be registered into NATS.

- When failing to start the engine first-time using the key of NATS V2.0, start as follows.

- (1) Turn ignition key to "OFF".
- (2) Wait approx. 5 seconds.
- (3) Turn ignition key to "START" again while keeping the key apart from any others on key-chain.

HOW TO USE THIS MANUAL

- THE LARGE ILLUSTRATIONS** are exploded views (See below.) and contain tightening torques, lubrication points and other information necessary to perform repairs. The illustrations should be used in reference to service matters only. When ordering parts, refer to the appropriate **PARTS CATALOG**.

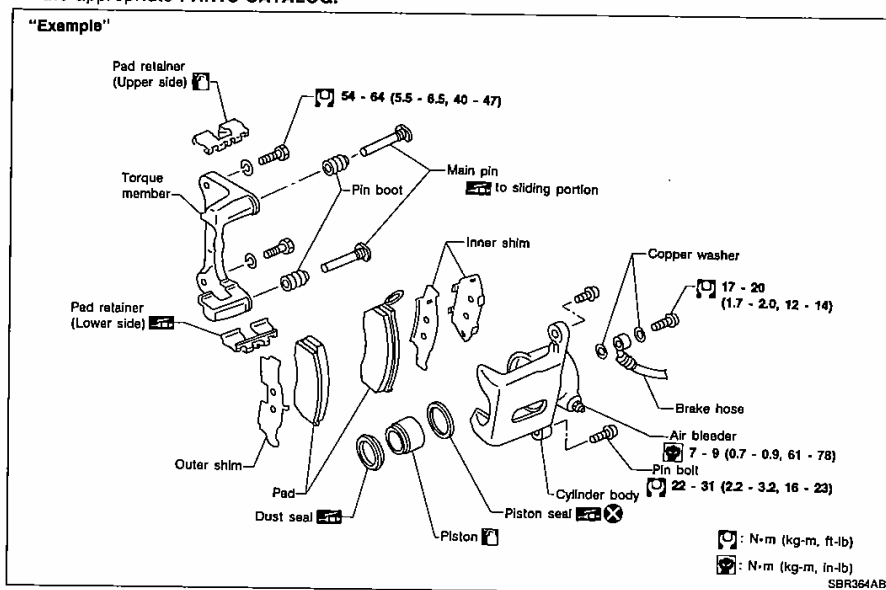

- The following **SYMBOLS AND ABBREVIATIONS** are used:

	: Tightening torque	A/C	: Air Conditioner
	: Should be lubricated with grease. Unless otherwise indicated, use recommended multi-purpose grease.	P/S	: Power Steering
	: Should be lubricated with oil.	Tool	: Special Service Tools
	: Sealing point	SDS	: Service Data and Specifications
	: Checking point	SAE	: Society of Automotive Engineers, Inc.
	: Always replace after every disassembly.	ATF	: Automatic Transmission Fluid
LH, RH	: Left-Hand, Right-Hand	D ₁	: Drive range 1st gear
FR, RR	: Front, Rear	D ₂	: Drive range 2nd gear
	: Apply petroleum jelly.	D ₃	: Drive range 3rd gear
	: Apply ATF	D ₄	: Drive range 4th gear
★	: Select with proper thickness.	OD	: Overdrive
☆	: Adjustment is required.	2 ₂	: 2nd range 2nd gear
M/T	: Manual Transaxle/Transmission	2 ₁	: 2nd range 1st gear
A/T	: Automatic Transaxle/Transmission	1 ₂	: 1st range 2nd gear
		1 ₁	: 1st range 1st gear

HOW TO READ WIRING DIAGRAMS

Wiring Diagram Codes (Cell Codes)

- Use the chart below to find out what each wiring diagram code stands for.
- Only the modified wiring diagrams are included in this service manual, as shown in the chart below.

Code	Section	Wiring Diagram Name
AAC/V	EC	IACV-AAC Valve
ABS	BR	Anti-lock Brake System
A/C, A	HA	Auto Air Conditioner
A/C, M	HA	Manual Air Conditioner
A/T	AT	Automatic Transmission
AT/C	EC	A/T Control
CHIME	EL	Warning Chime
CMPS	EC	Camshaft Position Sensor
COOL/F	EC	Cooling Fan Control
DEF/S	EC	Rear Window Defogger Signal
ECTS	EC	Engine Coolant Temperature Sensor
EGRC/V	EC	EGR and canister Control Solenoid Valve
F/FOG	EL	Front Fog Lamp
FICD	EC	IACV-FICD Solenoid Valve
F/PUMP	EC	Fuel Pump
HO2S	EC	Heated Oxygen Sensor
IGN/SG	EC	Ignition Signal
ILL	EL	Illumination
INJECT	EC	Injector
INT/L	EL	Interior, Spot and Trunk Room Lamps
KS	EC	Knock Sensor
MAFS	EC	Mass Air Flow Sensor
MAIN	EC	Main Power Supply and Ground Circuit
METER	EL	Speedometer, Tachometer, Temp. and Fuel Gauges
MIL	EC	MIL, Data Link Connector For Consult
MIRROR	EL	Door Mirror
MULTI	EL	Multi-remote Control System
NATS	EL	Nissan Anti-Theft System
PNP/SW	EC	Park/Neutral Position Switch
POWER	EL	Power Supply Routing
PST/SW	EC	Power Steering Oil Pressure Switch
R/FOG	EL	Rear Fog Lamp

Code	Section	Wiring Diagram Name
SRS	RS	Supplemental Restraint System
S/SIG	EC	Start Signal
THEFT	EL	Theft Warning System
TPS	EC	Throttle Position Sensor
TURN	EL	Turn Signal and Hazard Warning Lamps
VSS	EC	Vehicle Speed Sensor
VTC	EC	VTC Solenoid Valve
WARN	EL	Warning Lamps
WG/V	EC	Wastegate Valve Control Solenoid Valve
WINDOW	EL	Power Window

CONSULT CHECKING SYSTEM

Function and System Application

Diagnostic test mode	Function	ECCS	A/T	Air bag	ABS	NATS*1
Work support	This mode enables a technician to adjust some devices faster and more accurately by following the indications on CONSULT.	x	—	—	—	—
Self-diagnostic results	Self-diagnostic results can be read and erased quickly.	x	x	x	x	x
ECU discriminated No.	Classification number of a replacement ECU can be read to prevent an incorrect ECU from being installed.	—	—	x	—	—
Data monitor	Input/Output data in the ECM can be read.	x	x	—	x	—
Active test	Diagnostic Test Mode in which CONSULT drives some actuators apart from the ECMs and also shifts some parameters in a specified range.	x	—	—	x	—
ECM part number	ECM part number can be read.	x	x	—	x	—
Function test	Conducted by CONSULT instead of a technician to determine whether each system is "OK" or "NG".	x	—	—	—	—
Control unit initialisation	All registered ignition key IDs in NATS components can be initialised and new IDs can be registered.	—	—	—	—	x
Self-function check	ECM checks its own NATS communication interface.	—	—	—	—	x

x: Applicable

*1: NATS: Nissan Anti-Theft System

Checking Equipment

When ordering the below equipment, contact your NISSAN distributor.

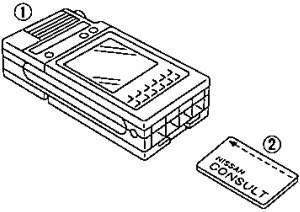
Tool name	Description
NISSAN CONSULT ① CONSULT unit and accessories ② Program card ● AE950 for Australia ● EE940 except for Australia ● NATS-E940*1 for NATS	

NT004

*1: An order for NATS program card must be placed only with NISSAN EUROPE N.V.

TIGHTENING TORQUE OF STANDARD BOLTS

Grade	Bolt size	Bolt diameter mm	Pitch mm	Tightening torque (Without lubricant)							
				Hexagon head bolt				Hexagon flange bolt			
				N·m	kg·m	ft·lb	in·lb	N·m	kg·m	ft·lb	in·lb
4T	M6	6.0	1.0	5.1	0.52	3.8	45.1	6.1	0.62	4.5	53.8
	M8	8.0	1.25	13	1.3	9	—	15	1.5	11	—
			1.0	13	1.3	9	—	16	1.6	12	—
	M10	10.0	1.5	25	2.5	18	—	29	3.0	22	—
			1.25	25	2.6	19	—	30	3.1	22	—
			1.75	42	4.3	31	—	51	5.2	38	—
	M12	12.0	1.25	46	4.7	34	—	56	5.7	41	—
1.5			74	7.5	54	—	88	9.0	65	—	
M14	14.0	1.5	74	7.5	54	—	88	9.0	65	—	
7T	M6	6.0	1.0	8.4	0.86	6.2	74.6	10	1.0	7	87
	M8	8.0	1.25	21	2.1	15	—	25	2.5	18	—
			1.0	22	2.2	16	—	26	2.7	20	—
	M10	10.0	1.5	41	4.2	30	—	48	4.9	35	—
			1.25	43	4.4	32	—	51	5.2	38	—
	M12	12.0	1.75	71	7.2	52	—	84	8.6	62	—
			1.25	77	7.9	57	—	92	9.4	68	—
M14	14.0	1.5	127	13.0	94	—	147	15.0	108	—	
9T	M6	6.0	1.0	12	1.2	9	—	15	1.5	11	—
	M8	8.0	1.25	29	3.0	22	—	35	3.6	26	—
			1.0	31	3.2	23	—	37	3.8	27	—
	M10	10.0	1.5	59	6.0	43	—	70	7.1	51	—
			1.25	62	6.3	46	—	74	7.5	54	—
	M12	12.0	1.75	98	10.0	72	—	118	12.0	87	—
			1.25	108	11.0	80	—	137	14.0	101	—
M14	14.0	1.5	177	18.0	130	—	206	21.0	152	—	

1. Special parts are excluded.
2. This standard is applicable to bolts having the following marks embossed on the bolt head.

Grade	Mark
4T	4
7T	7
9T	9

* : Nominal diameter

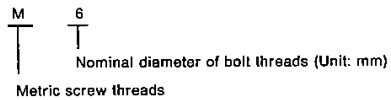

ENGINE CONTROL SYSTEM

SECTION **EC**

MODIFICATION NOTICE:

- The mass air flow sensor harness connector has been changed.
- The boost pressure sensor has been eliminated.
- The ECM harness connector has been changed from 76-pin type to 64-pin type (Europe models only).

EC

CONTENTS

ENGINE AND EMISSION CONTROL OVERALL	ENGINE AND EMISSION CONTROL SYSTEM
SYSTEM 2	DESCRIPTION 8
ECCS Component Parts Location..... 2	Boost Pressure Control 8
System Chart..... 3	IDLE SPEED/IGNITION TIMING/IDLE MIXTURE
System Diagram..... 4	RATIO INSPECTION..... 9
Vacuum Hose Drawing..... 5	TRouble DIAGNOSES 14
Circuit Diagram..... 6	Contents..... 14

When you read wiring diagrams:

- Read GI section, "HOW TO READ WIRING DIAGRAMS".
- See EL section, "POWER SUPPLY ROUTING" for power distribution circuit.

When you perform trouble diagnoses, read GI section, "HOW TO FOLLOW FLOW CHART IN TROUBLE DIAGNOSES" and "HOW TO PERFORM EFFICIENT DIAGNOSIS FOR AN ELECTRICAL INCIDENT".

ENGINE AND EMISSION CONTROL OVERALL SYSTEM

ECCS Component Parts Location

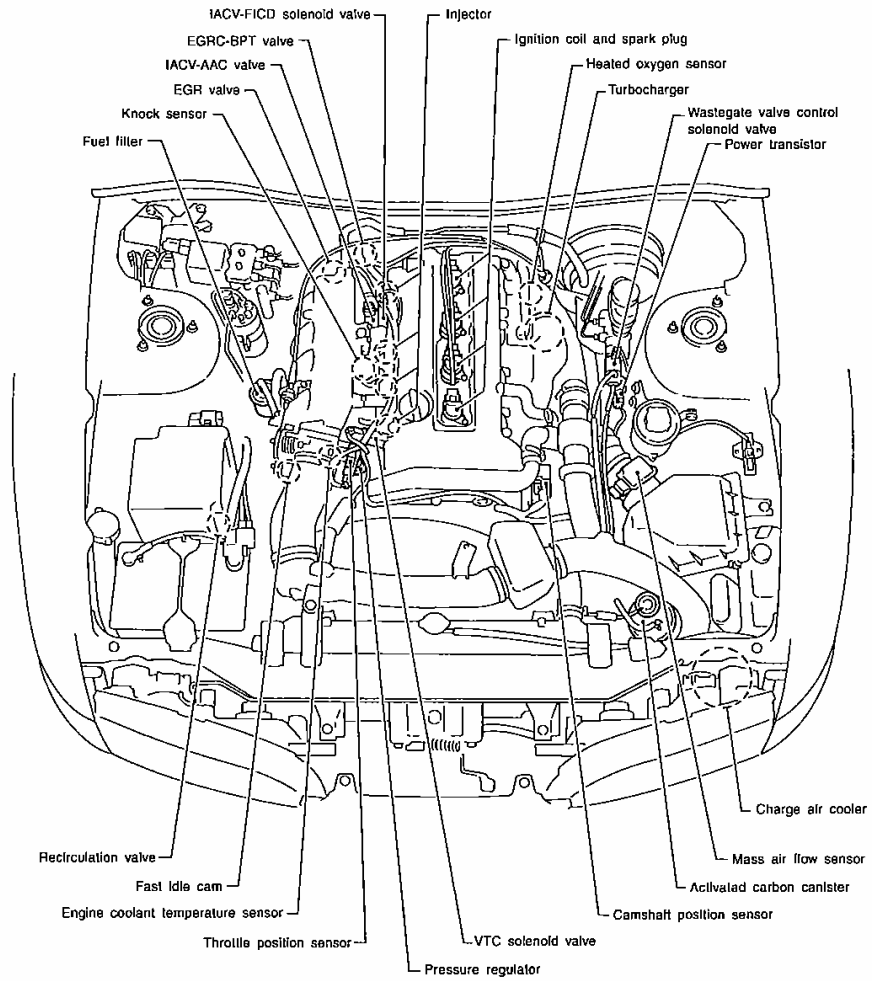

SEF628R

ENGINE AND EMISSION CONTROL OVERALL SYSTEM

System Chart

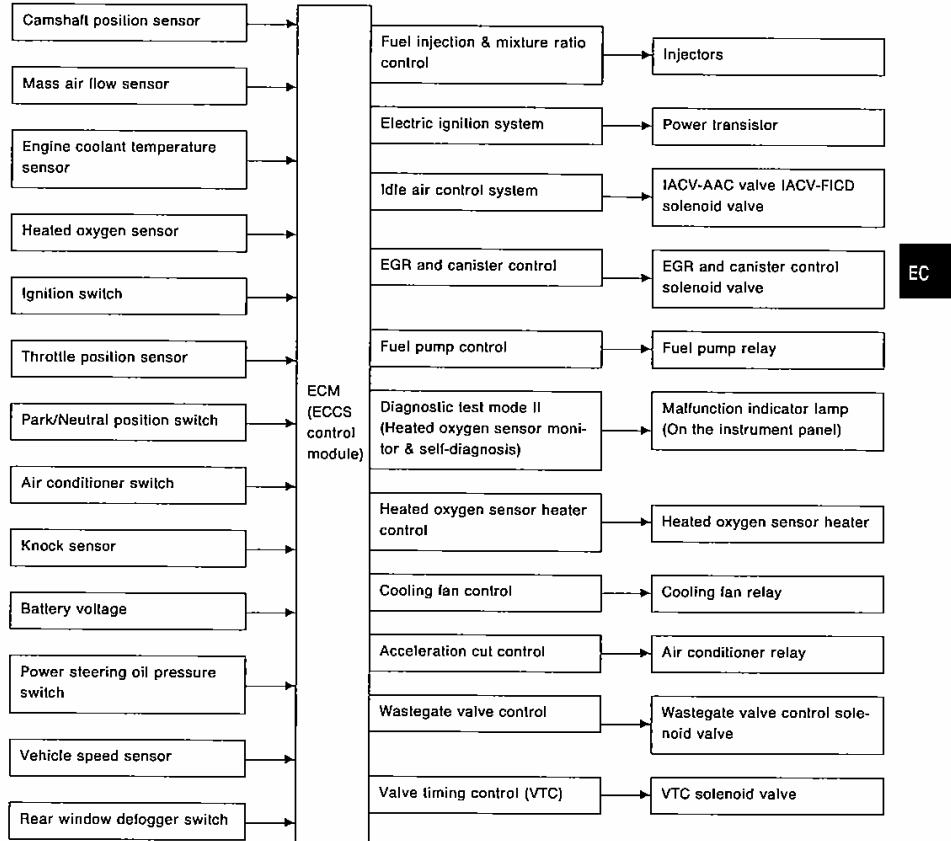

ENGINE AND EMISSION CONTROL OVERALL SYSTEM

System Diagram

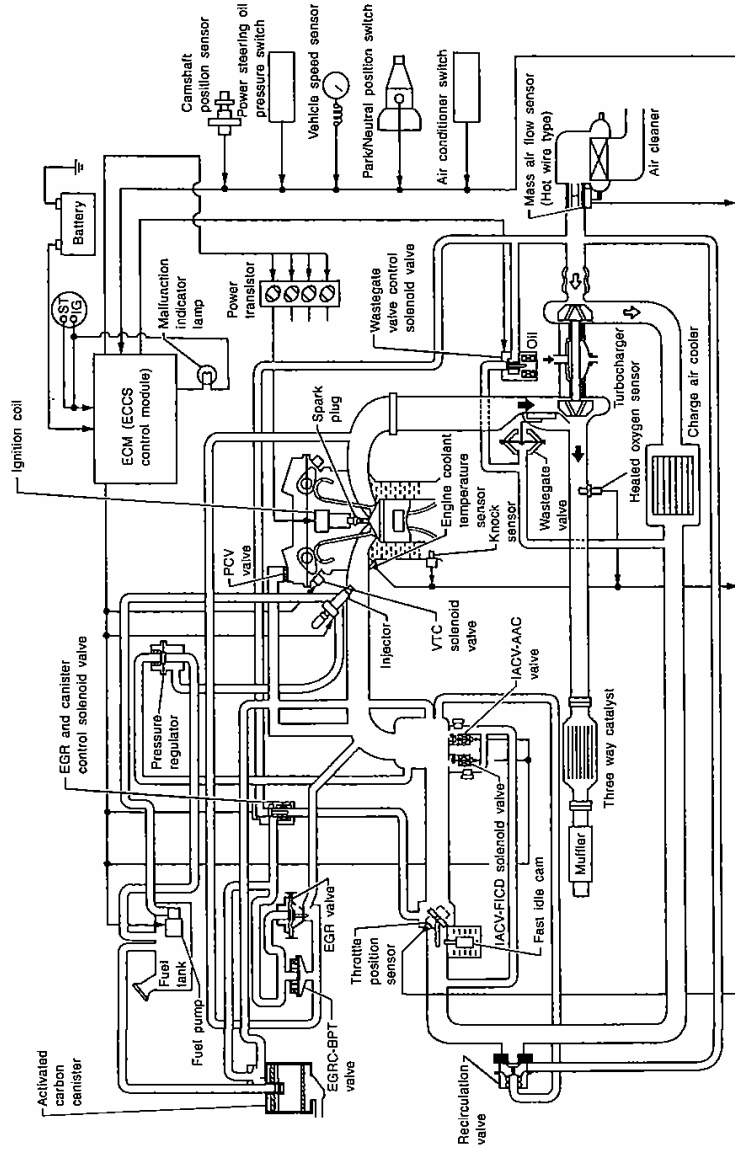

EC-4

SEF630R

ENGINE AND EMISSION CONTROL OVERALL SYSTEM

Vacuum Hose Drawing

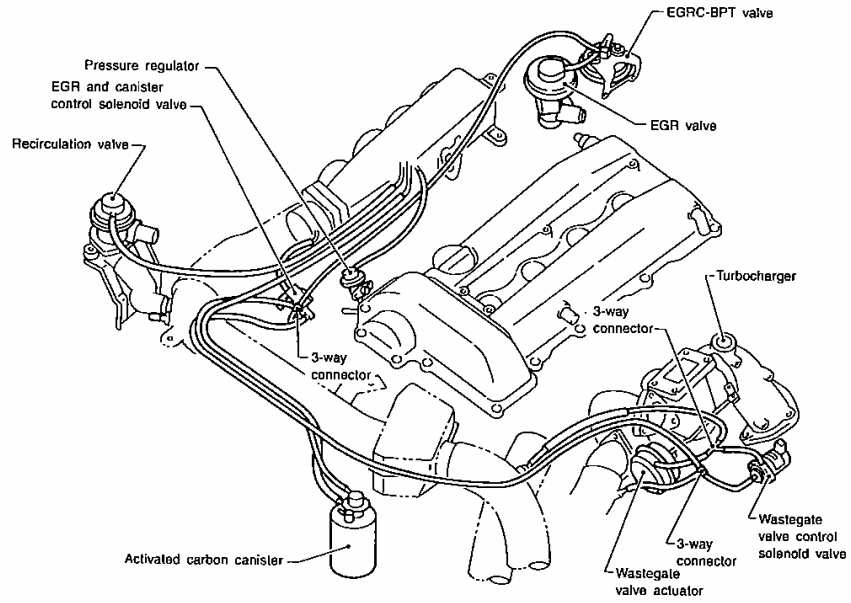

EC

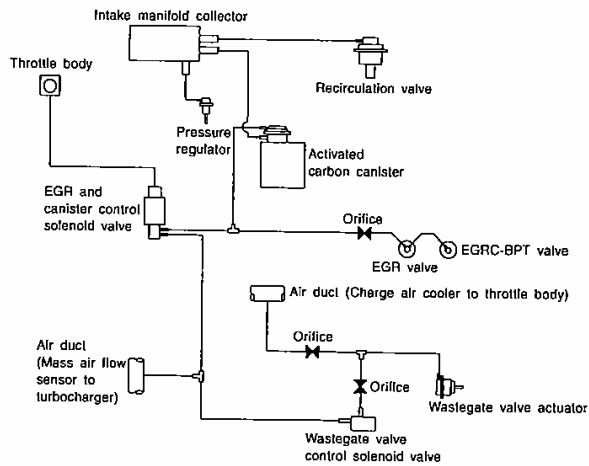

ENGINE AND EMISSION CONTROL OVERALL SYSTEM

Circuit Diagram

FOR EUROPE

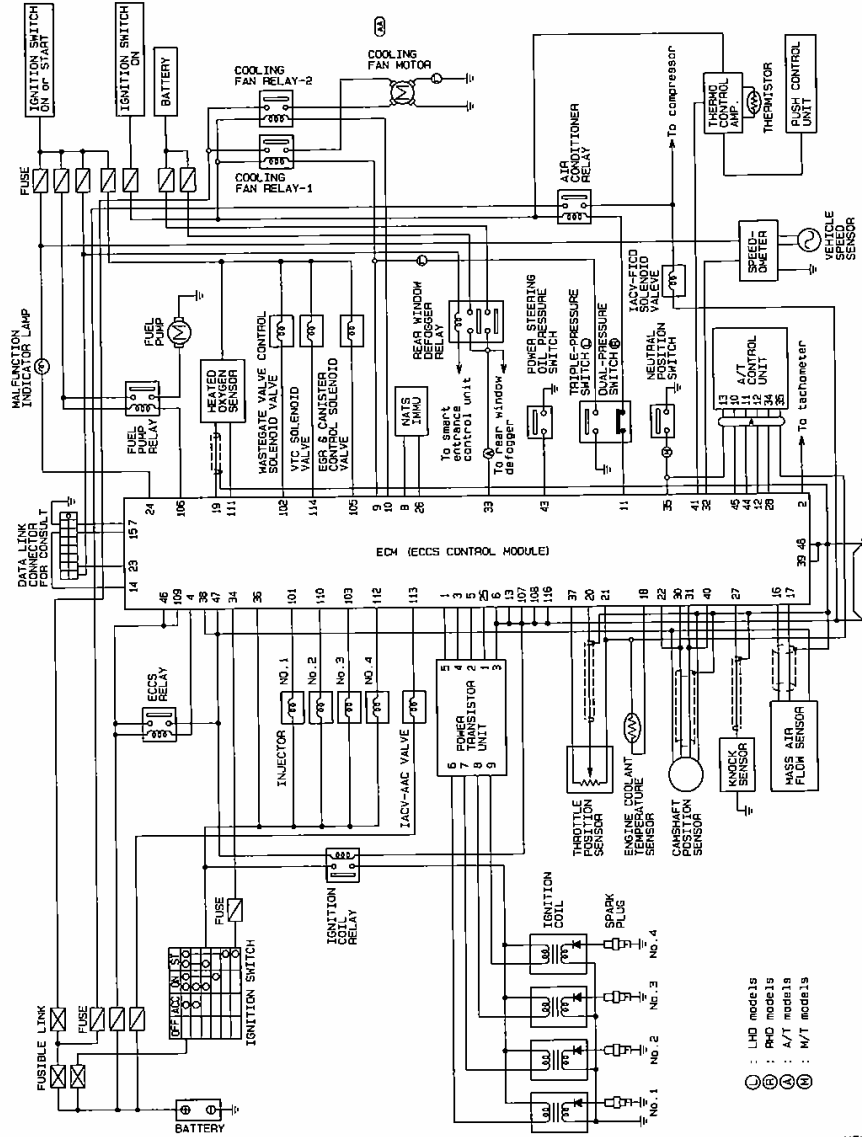

EC-6

HEC145

ENGINE AND EMISSION CONTROL OVERALL SYSTEM
Circuit Diagram (Cont'd)

EXCEPT FOR EUROPE

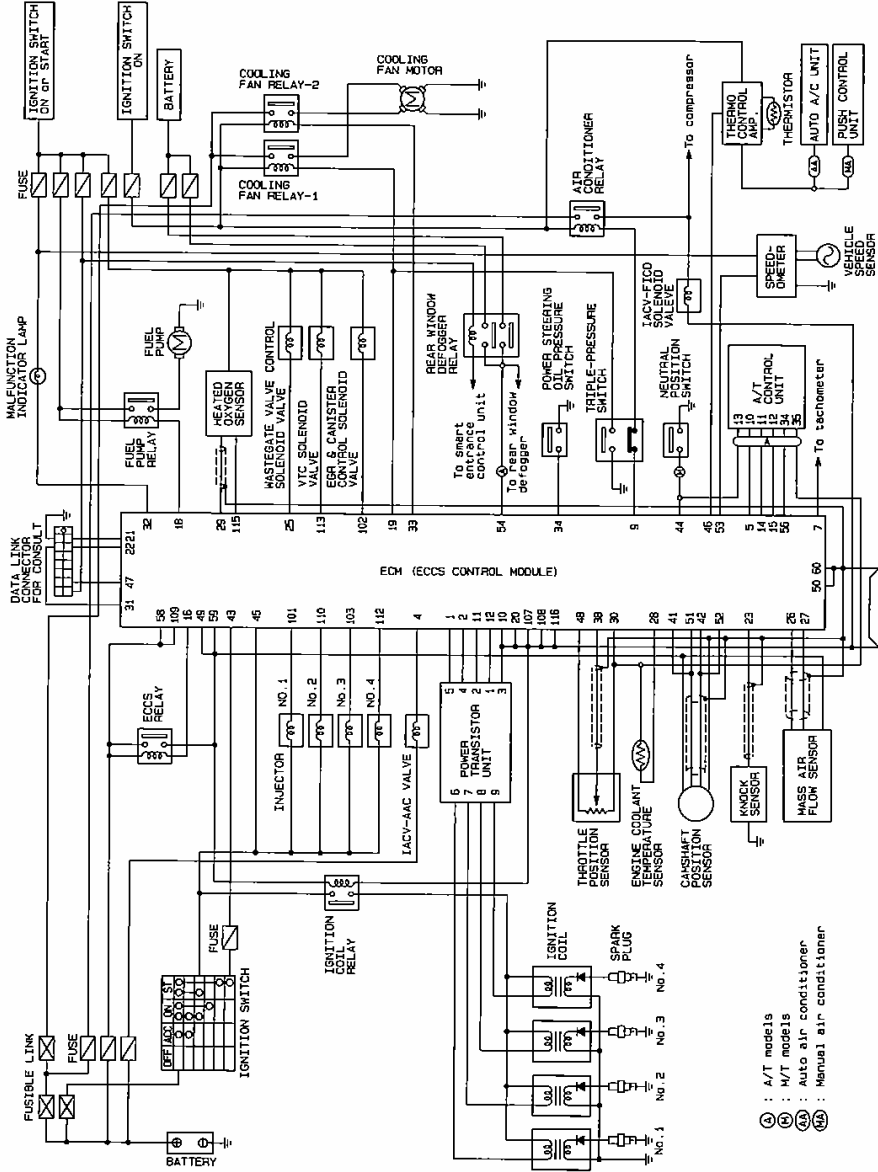

EC

ENGINE AND EMISSION CONTROL SYSTEM DESCRIPTION

Boost Pressure Control

INPUT/OUTPUT SIGNAL LINE

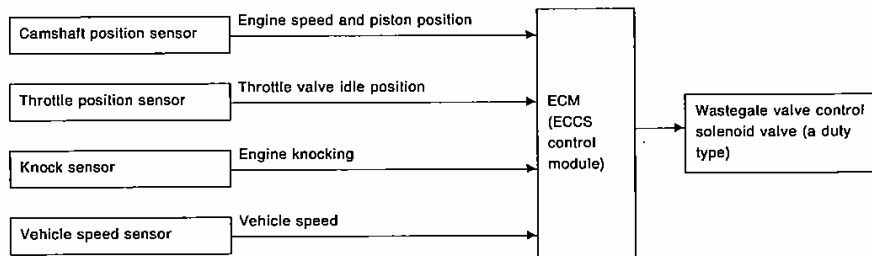

SYSTEM DESCRIPTION

The output signal maps of the ECM are selected according to fuel octane rating, gear position (M/T model) and vehicle speed (A/T model). The wastegate valve control solenoid valve

changes the source vacuum which activates the actuator. This results in a proportional boost pressure to the acceleration. Knock signs are used to determine fuel octane rating.

OPERATION

Fuel octane rating	Gear position or vehicle speed	Boost pressure control map
Premium	<ul style="list-style-type: none"> ● 1, 2 and 3 speed gears (M/T model) ● Less than 46 km/h (29 MPH) (A/T model) 	A slow response type
	<ul style="list-style-type: none"> ● 4 and 5 speed gears (M/T model) ● More than 46 km/h (29 MPH) (A/T model) 	A quick response type
Lower than the above	Any	Fixed

IDLE SPEED/IGNITION TIMING/IDLE MIXTURE RATIO INSPECTION

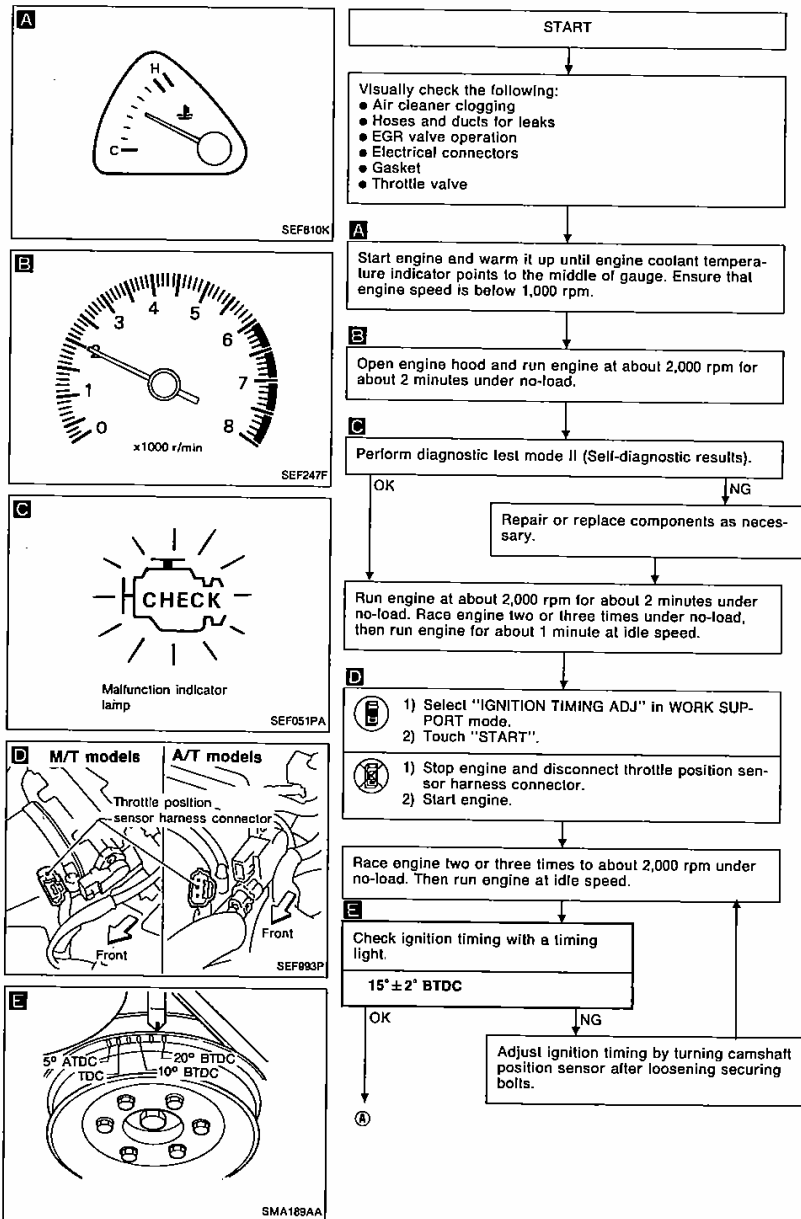

EC

IDLE SPEED/IGNITION TIMING/IDLE MIXTURE RATIO INSPECTION

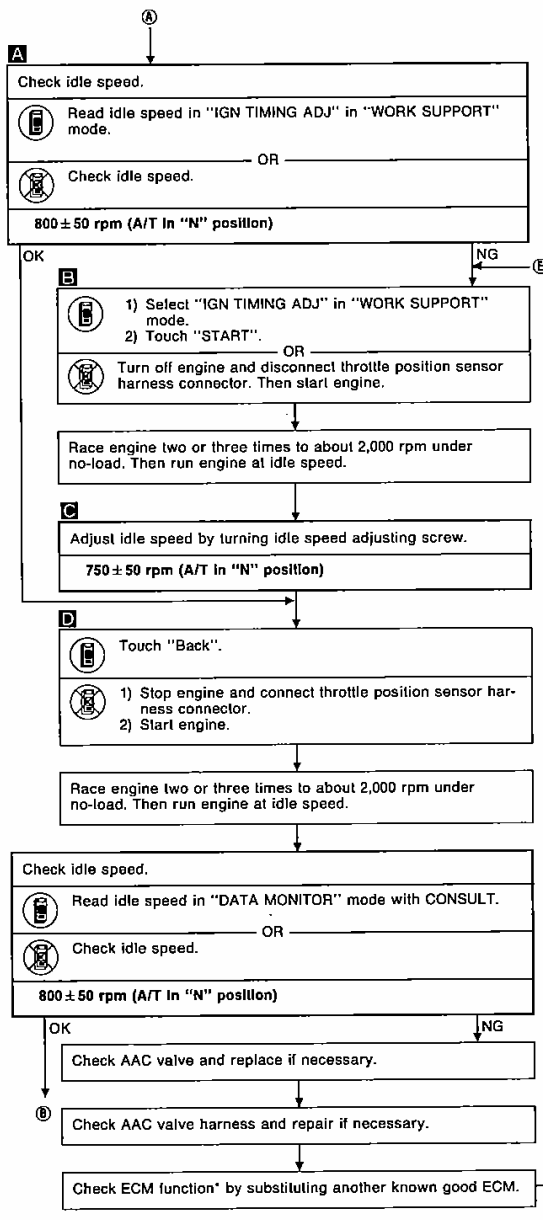
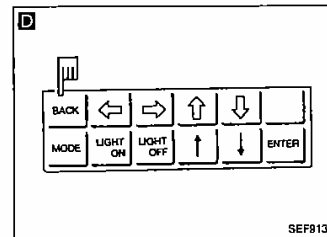
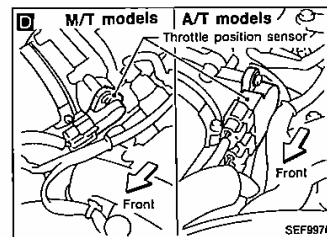
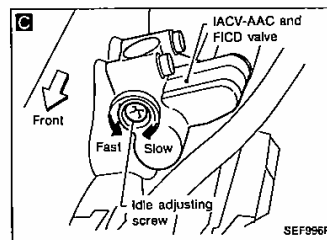
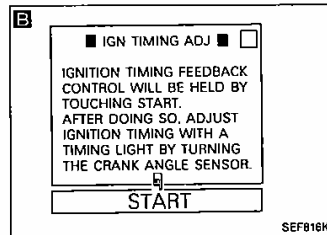
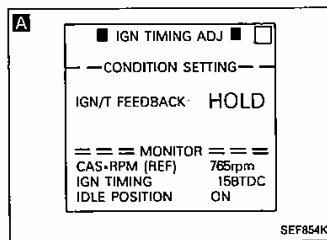

*: ECM may be the cause of a problem, but this is rarely the case. ③

IDLE SPEED/IGNITION TIMING/IDLE MIXTURE RATIO INSPECTION

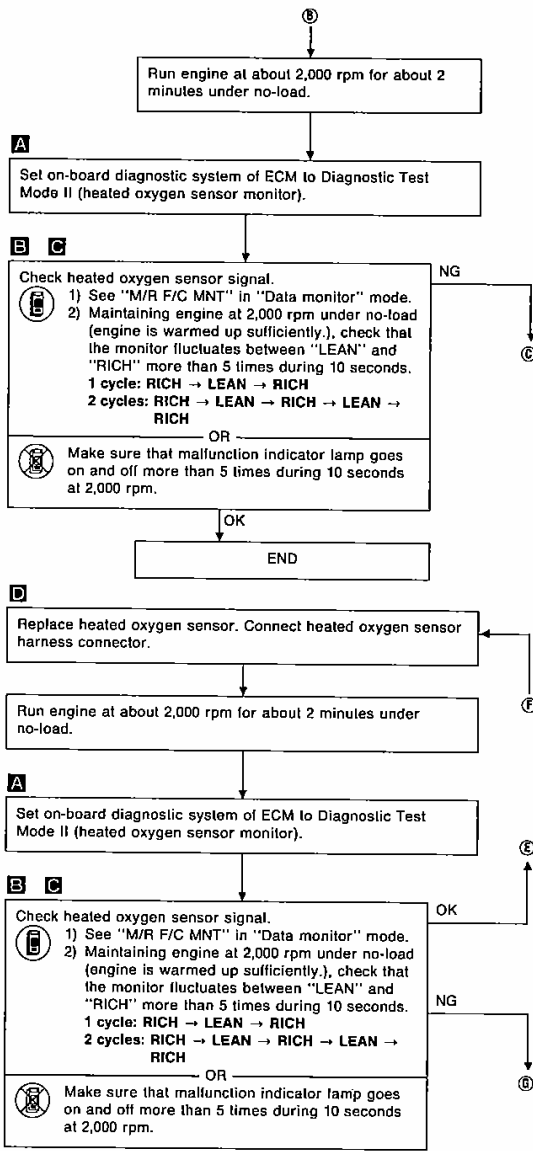
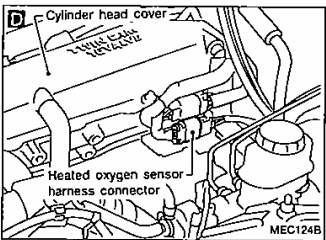
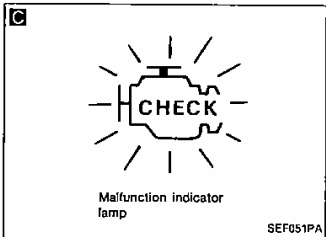
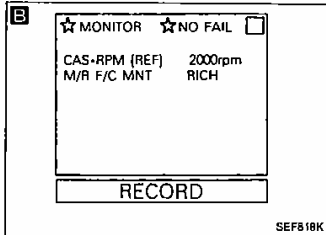
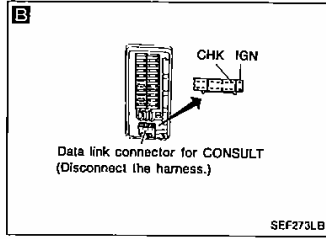
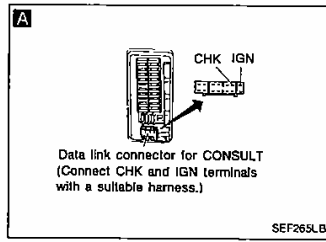

EC

IDLE SPEED/IGNITION TIMING/IDLE MIXTURE RATIO INSPECTION

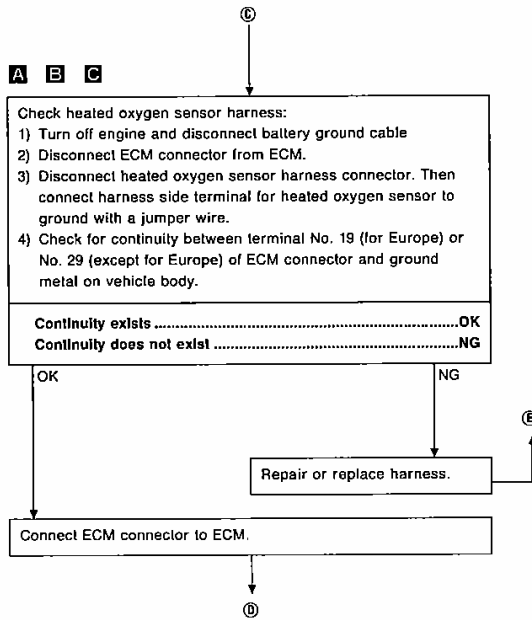
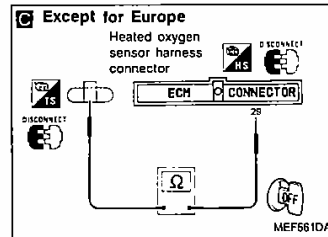
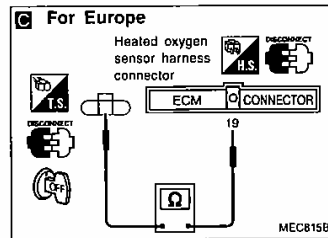
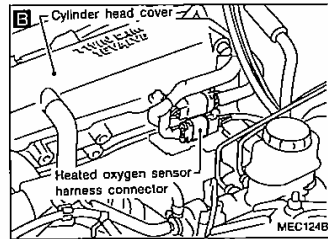
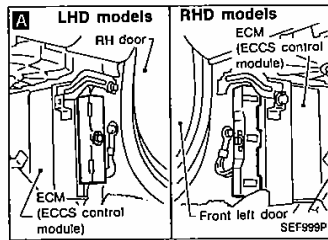

IDLE SPEED/IGNITION TIMING/IDLE MIXTURE RATIO INSPECTION

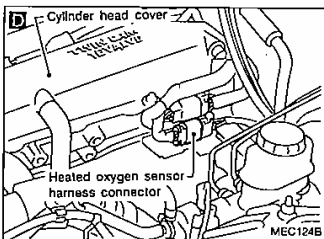
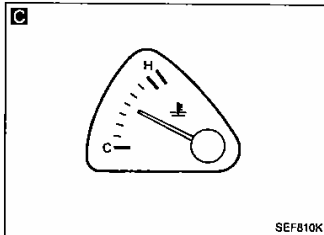
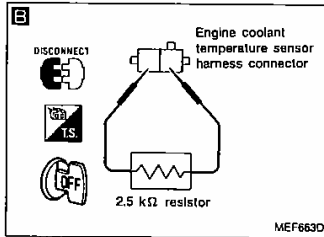
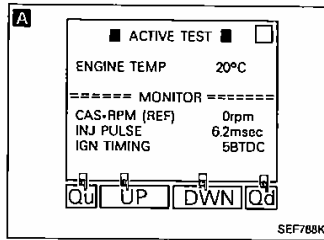

- ①
- A B**
- 1) Select "ENGINE TEMP" or "ENG COOLANT TEMP" in "ACTIVE TEST" mode.
 - 2) Set "ENG COOLANT TEMP" to 20°C (68°F) by touching "DWN" and "Qd".
- OR
- 1) Disconnect engine coolant temperature sensor harness connector.
 - 2) Connect a resistor (2.5 kΩ) between terminals of engine coolant temperature sensor harness connector.

C

Start engine and warm it up until engine coolant temperature indicator points to the middle of gauge. (Be sure to start engine after installing a 2.5 kΩ resistor.)

Race engine two or three times under no-load, then run engine at idle speed.

Check "CO" %.

Idle CO: Less than 10% (and engine runs smoothly)

After checking CO%.

- 1) Disconnect the resistor from terminals of engine coolant temperature sensor.
- 2) Connect engine coolant temperature sensor harness connector to engine coolant temperature sensor.

NG

D

Connect heated oxygen sensor harness connector to heated oxygen sensor.

Check fuel pressure regulator.

Check mass air flow sensor.

Check injector.
Clean or replace if necessary.

Check engine coolant temperature sensor.

Check ECM function* by substituting another known good ECM.

*: ECM may be the cause of a problem, but this is rarely the case.

EC

TROUBLE DIAGNOSES

Contents

On-board Diagnostic System — Diagnostic Test Mode II (Self-diagnostic results)	EC-16
CONSULT	EC-18
<hr/> FOR EUROPE <hr/>	
Diagnostic Procedure 22	
MAIN POWER SUPPLY AND GROUND CIRCUIT (Not self-diagnostic item)	EC-19
Diagnostic Procedure 23	
CAMSHAFT POSITION SENSOR (Diagnostic trouble code No. 11)	EC-23
Diagnostic Procedure 24	
MASS AIR FLOW SENSOR (Diagnostic trouble code No. 12)	EC-26
Diagnostic Procedure 25	
ENGINE COOLANT TEMPERATURE SENSOR (Diagnostic trouble code No. 13)	EC-29
Diagnostic Procedure 26	
IGNITION SIGNAL (Diagnostic trouble code No. 21)	EC-32
Diagnostic Procedure 28	
KNOCK SENSOR (Diagnostic trouble code No. 34)	EC-39
Diagnostic Procedure 29	
THROTTLE POSITION SENSOR (Diagnostic trouble code No. 43)	EC-41
Diagnostic Procedure 30	
A/T CONTROL (Diagnostic trouble code No. 54)	EC-44
Diagnostic Procedure 31	
START SIGNAL (Not self-diagnostic item)	EC-46
Diagnostic Procedure 32	
VEHICLE SPEED SENSOR (Not self-diagnostic item)	EC-49
Diagnostic Procedure 33	
EGR AND CANISTER CONTROL (Not self-diagnostic item)	EC-51
Diagnostic Procedure 34	
HEATED OXYGEN SENSOR (Not self-diagnostic item)	EC-55
Diagnostic Procedure 35	
INJECTOR CIRCUIT (Not self-diagnostic item)	EC-58
Diagnostic Procedure 36	
FUEL PUMP (Not self-diagnostic item)	EC-61
Diagnostic Procedure 37	
WASTEGATE VALVE CONTROL (Not self-diagnostic item)	EC-64
Diagnostic Procedure 38	
VTC CONTROL (Not self-diagnostic item)	EC-67
Diagnostic Procedure 39	
IACV-AAC VALVE (Not self-diagnostic item)	EC-70
Diagnostic Procedure 40	
IACV-FICD SOLENOID VALVE (Not self-diagnostic item)	EC-73
Diagnostic Procedure 41	
COOLING FAN CONTROL (Not self-diagnostic item)	EC-77
Diagnostic Procedure 42	
POWER STEERING OIL PRESSURE SWITCH (Not self-diagnostic item)	EC-85
Diagnostic Procedure 43	
NEUTRAL POSITION SWITCH & A/T CONTROL UNIT (PARK/NEUTRAL POSITION SIGNAL) (Not self-diagnostic item)	EC-87
Diagnostic Procedure 44	
REAR WINDOW DEFOGGER SWITCH (Not self-diagnostic item)	EC-91

TROUBLE DIAGNOSES

Contents (Cont'd)

Diagnostic Procedure 45 MALFUNCTION INDICATOR LAMP & DATA LINK CONNECTOR FOR CONSULT (Not self-diagnostic item)	EC-93
EXCEPT FOR EUROPE	
Diagnostic Procedure 22 MAIN POWER SUPPLY AND GROUND CIRCUIT (Not self-diagnostic item)	EC-94
Diagnostic Procedure 23 CAMSHAFT POSITION SENSOR (Diagnostic trouble code No. 11)	EC-98
Diagnostic Procedure 24 MASS AIR FLOW SENSOR (Diagnostic trouble code No. 12)	EC-101
Diagnostic Procedure 25 ENGINE COOLANT TEMPERATURE SENSOR (Diagnostic trouble code No. 13)	EC-104
Diagnostic Procedure 26 IGNITION SIGNAL (Diagnostic trouble code No. 21)	EC-107
Diagnostic Procedure 29 THROTTLE POSITION SENSOR (Diagnostic trouble code No. 43)	EC-114
Diagnostic Procedure 30 A/T CONTROL (Diagnostic trouble code No. 54)	EC-117
Diagnostic Procedure 33 EGR AND CANISTER CONTROL (Not self-diagnostic item)	EC-119
Diagnostic Procedure 34 HEATED OXYGEN SENSOR (Not self-diagnostic item)	EC-123
Diagnostic Procedure 35 INJECTOR CIRCUIT (Not self-diagnostic item)	EC-124
Diagnostic Procedure 36 FUEL PUMP (Not self-diagnostic item)	EC-125
Diagnostic Procedure 40 IACV-FICD SOLENOID VALVE (Not self-diagnostic item)	EC-128
Diagnostic Procedure 43 NEUTRAL POSITION SWITCH & A/T CONTROL UNIT (PARK/NEUTRAL POSITION SIGNAL) (Not self-diagnostic item)	EC-130
FOR ALL AREAS	
Electrical Components Inspection	EC-132

EC

TROUBLE DIAGNOSES

On-board Diagnostic System — Diagnostic Test Mode II (Self-diagnostic results)

Display diagnostic trouble code table

Diagnostic trouble code No.	Detected items
11*	Camshaft position sensor circuit
12	Mass air flow sensor circuit
13	Engine coolant temperature sensor circuit
21*	Ignition signal circuit
34	Knock sensor circuit
43	Throttle position sensor circuit
54	Signal circuit from A/T control unit to ECM
55	No malfunction in the above circuits

*: Check items causing a malfunction of camshaft position sensor circuit first, if both "CAMSHAFT POSITION SENSOR (No. 11)" and "IGN SIGNAL-PRIMARY (No. 21)" are displayed one after the other.

Diagnostic trouble code No.	Detected items	Malfunction is detected when ...	Check item (remedy)
11*	Camshaft position sensor circuit	<ul style="list-style-type: none"> ● Either 1° or 180° signal is not entered for the first few seconds during engine cranking. ● Either 1° or 180° signal is not input often enough while the engine speed is higher than the specified rpm. 	<ul style="list-style-type: none"> ● Harness and connector (If harness and connector are normal, replace camshaft position sensor.)
12	Mass air flow sensor circuit	<ul style="list-style-type: none"> ● The mass air flow sensor circuit is open or shorted. (An abnormally high or low voltage is entered.) 	<ul style="list-style-type: none"> ● Harness and connector (If harness and connector are normal, replace mass air flow sensor.)
13	Engine coolant temperature sensor circuit	<ul style="list-style-type: none"> ● The engine coolant temperature sensor circuit is open or shorted. (An abnormally high or low output voltage is entered.) 	<ul style="list-style-type: none"> ● Harness and connector ● Engine coolant temperature sensor
21*	Ignition signal circuit	<ul style="list-style-type: none"> ● The ignition signal in the primary circuit is not entered during engine cranking or running. 	<ul style="list-style-type: none"> ● Harness and connector ● Power transistor unit
34	Knock sensor circuit	<ul style="list-style-type: none"> ● The knock sensor circuit is open or shorted. (An abnormally high or low voltage is entered.) 	<ul style="list-style-type: none"> ● Harness and connector ● Knock sensor
43	Throttle position sensor circuit	<ul style="list-style-type: none"> ● The throttle position sensor circuit is open or shorted. (An abnormally high or low voltage is entered.) 	<ul style="list-style-type: none"> ● Harness and connector ● Throttle position sensor
54	Signal circuit from A/T control unit to ECM (A/T only)	<ul style="list-style-type: none"> ● The A/T communication line is open or shorted. 	<ul style="list-style-type: none"> ● Harness and connector

*: Check items causing a malfunction of camshaft position sensor circuit first, if both "CAMSHAFT POSITION SENSOR (No. 11)" and "IGN SIGNAL-PRIMARY (No. 21)" are displayed one after the other.

TROUBLE DIAGNOSES

On-board Diagnostic System — Diagnostic Test Mode II (Self-diagnostic results) (Cont'd)

HOW TO ERASE DIAGNOSTIC TEST MODE II (SELF-DIAGNOSTIC RESULTS)

The diagnostic trouble code is erased from the backup memory on the ECM when the diagnostic test mode is changed from Diagnostic Test Mode II to Diagnostic Test Mode I. (Refer to "HOW TO SWITCH DIAGNOSTIC TEST MODES".)

- If the battery terminal is disconnected, the diagnostic trouble code will be lost from the backup memory within 24 hours.
- Be careful not to erase the stored memory before starting trouble diagnoses.

EC

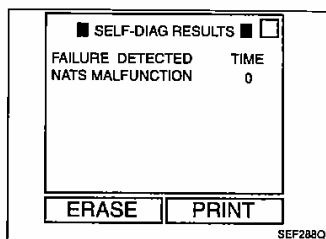

For Europe models

- If the MIL blinks or "NATS MALFUNCTION" is displayed on "SELF-DIAG RESULTS" screen, perform self-diagnostic results mode with CONSULT using NATS program card (NATS-E940). Refer to EL section.
- Confirm no self-diagnostic results of NATS is displayed before touching "ERASE" in "SELF-DIAG RESULTS" mode with CONSULT.
- When replacing ECM, initialisation of NATS V2.0 system and registration of all NATS V2.0 Ignition key IDs must be carried out with CONSULT using NATS program card (NATS-E940).

Therefore, be sure to receive all keys from vehicle owner. Regarding the procedures of NATS initialisation and NATS Ignition key ID registration, refer to CONSULT operation manual, NATS V2.0.

TROUBLE DIAGNOSES

CONSULT

ECCS COMPONENT PARTS APPLICATION

ECCS COMPONENT PARTS		DIAGNOSTIC TEST MODE				
		WORK SUP- PORT	SELF- DIAGNOSTIC RESULTS	DATA MONI- TOR	ACTIVE TEST	FUNCTION TEST
INPUT	Camshaft position sensor		X	X		
	Mass air flow sensor		X	X		
	Engine coolant temperature sensor		X	X	X	
	Heated oxygen sensors			X		X
	Vehicle speed sensors			X		X
	Throttle position sensor	X	X	X		X
	Knock sensor		X			
	Ignition switch (start signal)			X		X
	Air conditioner switch			X		
	Park/Neutral position switch			X		X
	Power steering oil pressure switch			X		X
	Battery			X		
	A/T signal		X			
	Injectors			X	X	X
OUTPUT	Power transistor (ignition timing)	X	X (Ignition signal)	X	X	X
	IACV-AAC valve	X		X	X	X
	Valve timing control solenoid valve			X	X	X
	EGRC-solenoid valve			X	X	X
	Air conditioner relay			X		
	Fuel pump relay	X		X	X	X
	Cooling fan relay			X	X	X
	Wastegate valve control solenoid valve			X		

X: Applicable

Diagnostic Procedure 22

MAIN POWER SUPPLY AND GROUND CIRCUIT (Not self-diagnostic item)

EC-MAIN-01

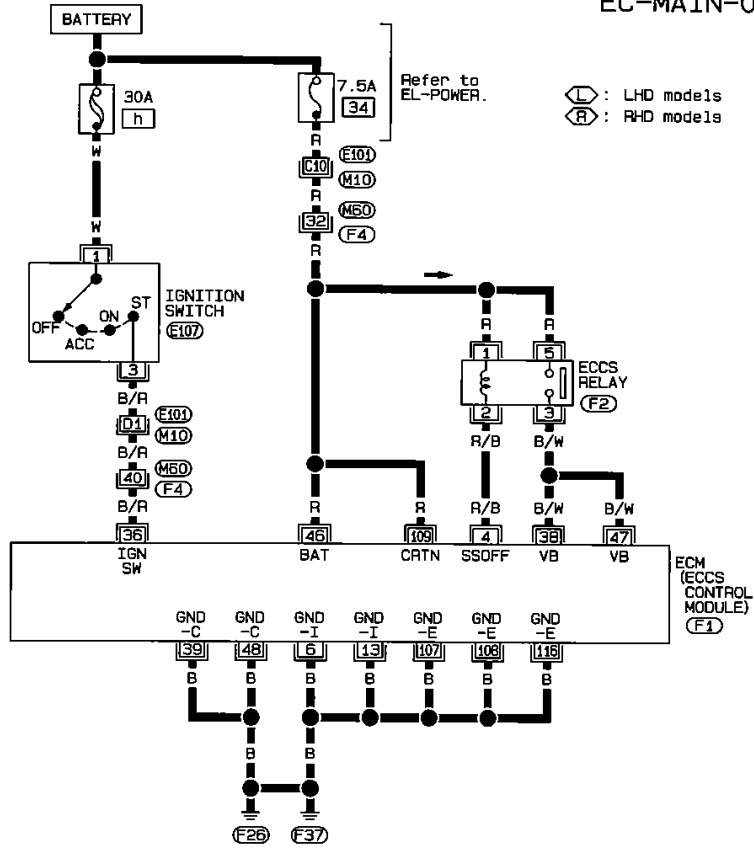

EC

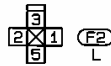
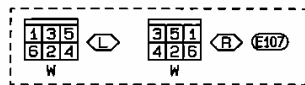

Refer to last page (Foldout page).

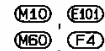

TROUBLE DIAGNOSES

For Europe

Diagnostic Procedure 22 (Cont'd)

Harness layout

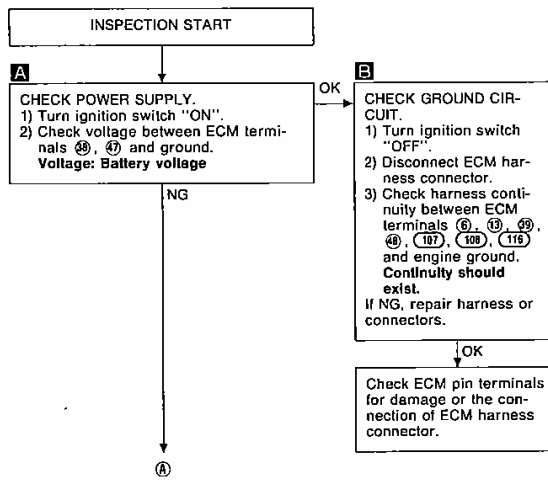
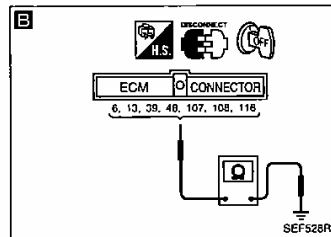
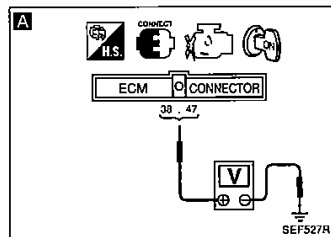
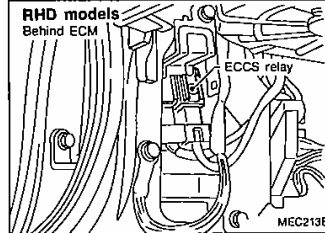
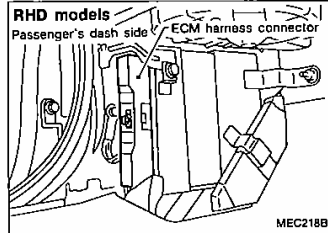
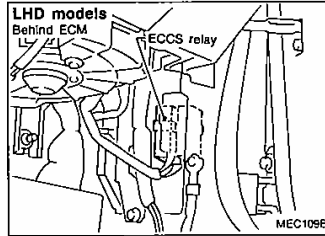
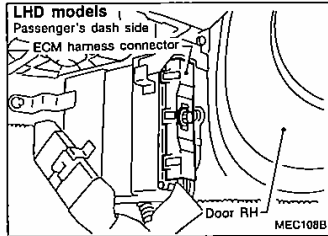

TROUBLE DIAGNOSES

For Europe

Diagnostic Procedure 22 (Cont'd)

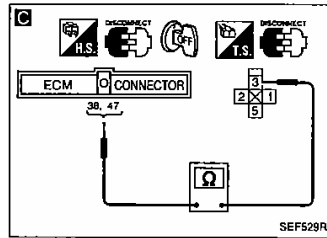

C
CHECK HARNESS CONTINUITY BETWEEN ECCS RELAY AND ECM.
 1) Turn ignition switch "OFF".
 2) Disconnect ECM harness connector.
 3) Disconnect ECCS relay.
 4) Check harness continuity between ECM terminals ④, ⑦ and terminal ③.
Continuity should exist.
 If OK, check harness for short.

NG → Repair harness or connectors.

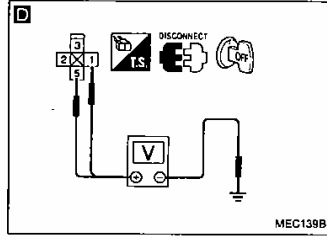

D
CHECK VOLTAGE BETWEEN ECCS RELAY AND GROUND.
 1) Check voltage between terminals ①, ⑤ and ground.
Voltage: Battery voltage

NG → Check the following.
 • 30A fusible link
 • 7.5A fuse
 • Harness connectors (E10), (M10)
 • Harness connectors (M60), (F4)
 • Harness for open or short between ECCS relay and battery
 If NG, repair harness or connectors.

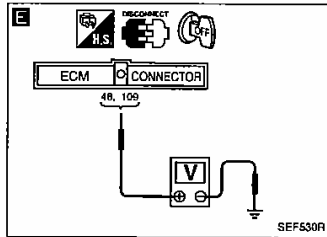

E
CHECK VOLTAGE BETWEEN ECM AND GROUND.
 1) Check voltage between ECM terminals ⑧, (100) and ground.
Voltage: Battery voltage

NG → Check the following.
 • Harness for open or short between ECM and harness connector (F4)
 If NG, repair harness or connectors.

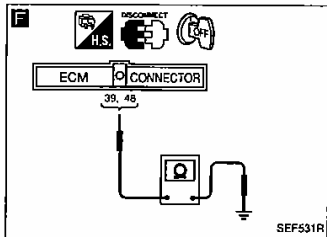

F
CHECK GROUND CIRCUIT.
 1) Check harness continuity between ECM terminals ⑨, ⑫ and engine ground.
Continuity should exist.
 If OK, check harness for short.

NG → Repair harness or connectors.

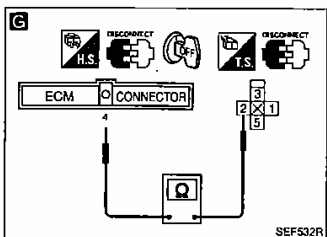

G
CHECK OUTPUT SIGNAL CIRCUIT.
 1) Check harness continuity between ECM terminal ④ and terminal ②.
Continuity should exist.
 If OK, check harness for short.

NG → Repair harness or connectors.

⑧

EC

TROUBLE DIAGNOSES

For Europe

Diagnostic Procedure 22 (Cont'd)

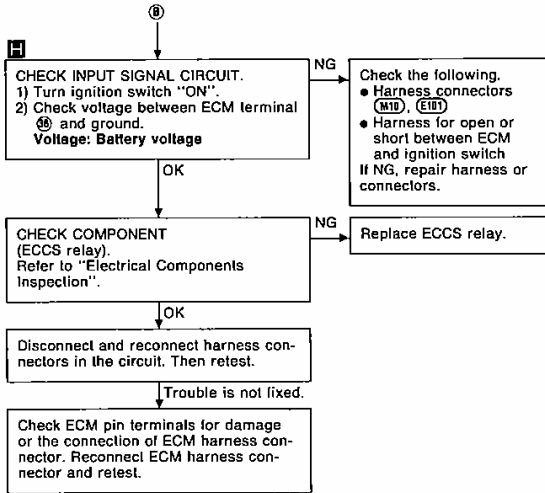
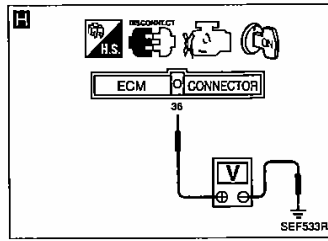

Diagnostic Procedure 23

CAMSHAFT POSITION SENSOR (Diagnostic trouble code No. 11)

EC-CMPS-01

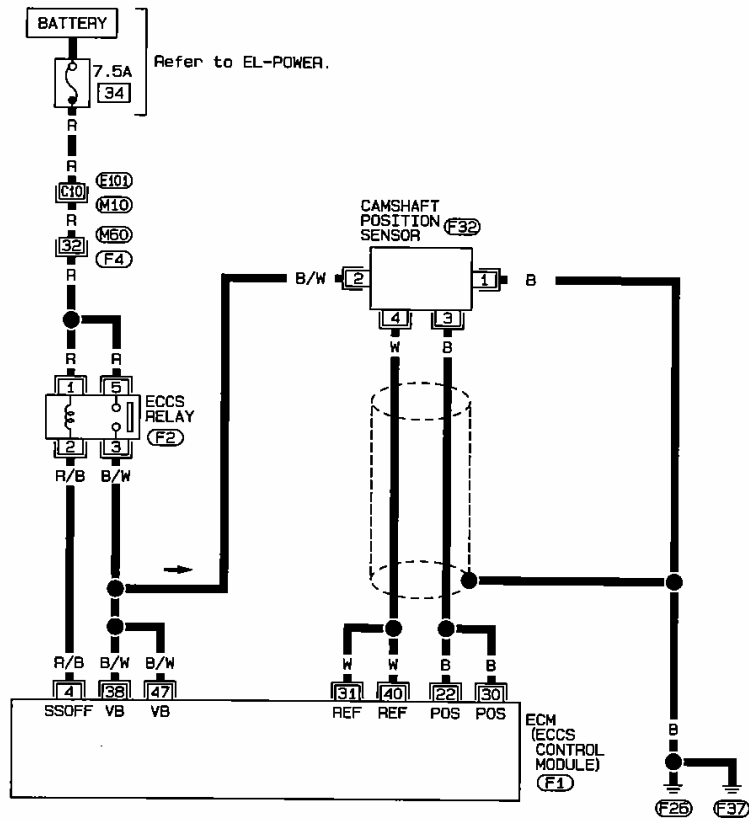

EC

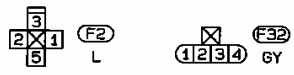

Refer to last page (Foldout page).

- (M10), (E10)
- (M50), (F4)

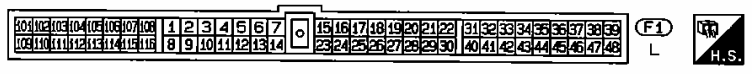

TROUBLE DIAGNOSES

For Europe

Diagnostic Procedure 23 (Cont'd)

Harness layout

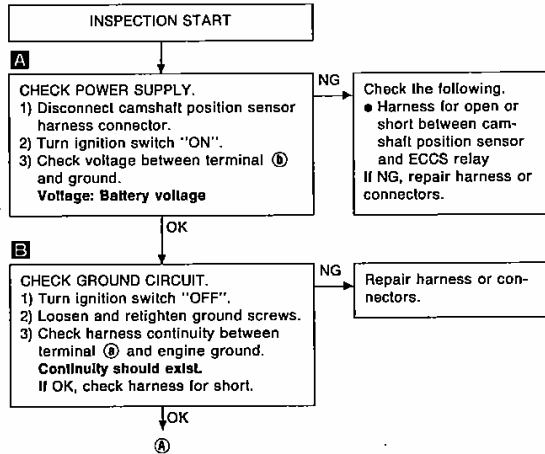
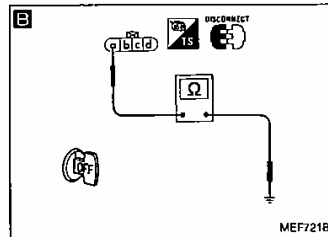
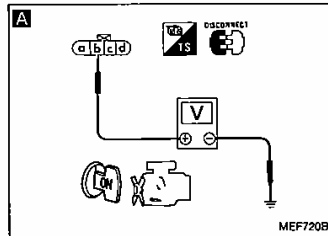
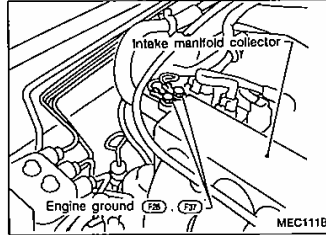
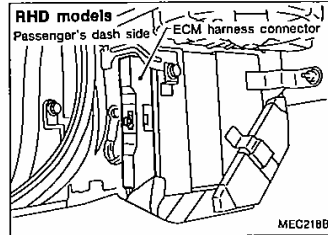
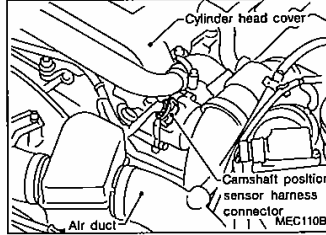
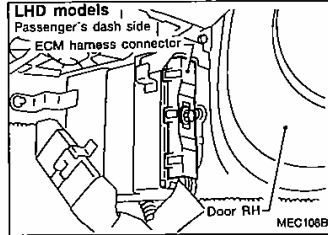

Diagnostic Procedure 23 (Cont'd)

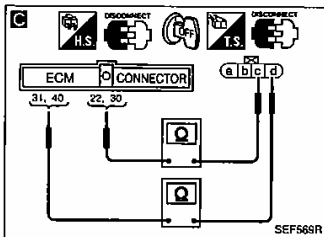
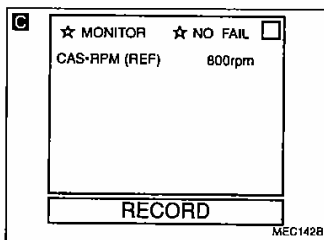

④
C
CHECK INPUT SIGNAL CIRCUIT.
 1) Reconnect camshaft position sensor harness connector.
 2) Start engine.
 3) Read "CAS-RPM" or "CMPS-RPM" signal in "DATA MONITOR" mode with CONSULT.
800 ± 50 rpm (A/T: In "N" position)

NG → Repair harness or connectors.

OR
 1) Disconnect ECM harness connector.
 2) Check harness continuity between terminal ④ and ECM terminals ②, ③ (1° signal), terminal ④ and ECM terminals ⑤, ⑥ (180° signal).
Continuity should exist.
 If OK, check harness for short.

EC

OK
CHECK COMPONENT
 (Camshaft position sensor). Refer to "Electrical Components Inspection".

NG → Replace camshaft position sensor.

OK
 Disconnect and reconnect harness connectors in the circuit. Then retest.

Trouble is not fixed.
 Check ECM pin terminals for damage or the connection of ECM harness connector. Reconnect ECM harness connector and retest.

Perform FINAL CHECK by the following procedure after repair is completed.

FINAL CHECK

1) Erase the diagnostic test mode II (Self-diagnostic results) memory.
 2) Perform test drive.
 3) Perform diagnostic test mode II (Self-diagnostic results) again.

NG → Recheck ECM pin terminals for damage or the connection of ECM harness connector.

OK
 INSPECTION END

Diagnostic Procedure 24

MASS AIR FLOW SENSOR (Diagnostic trouble code No. 12)

EC-MAFS-01

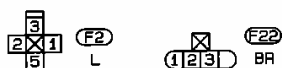
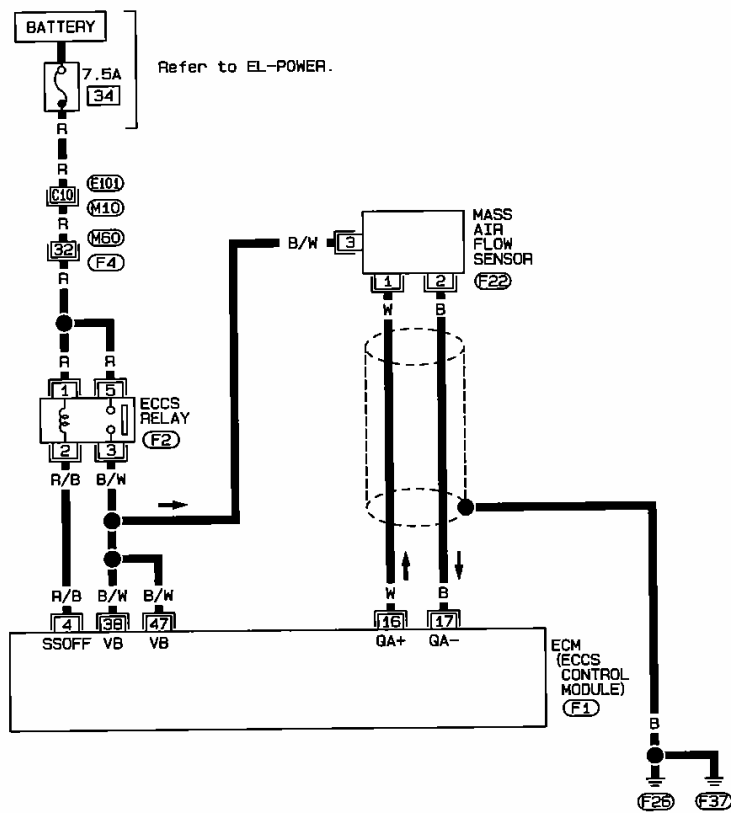

Refer to last page (Foldout page).

- M10, E10
- M60, F4



F1
L



TROUBLE DIAGNOSES

For Europe

Diagnostic Procedure 24 (Cont'd)

Harness layout

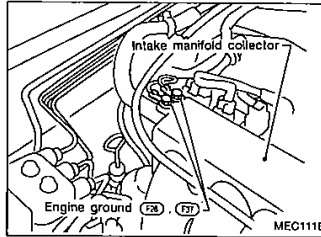
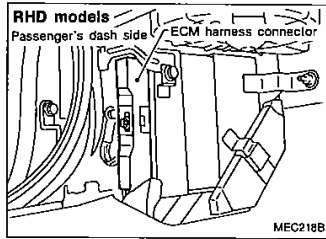
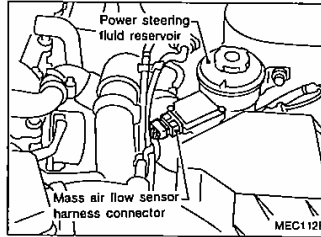
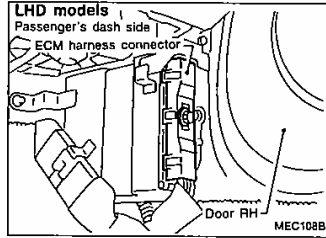

EC

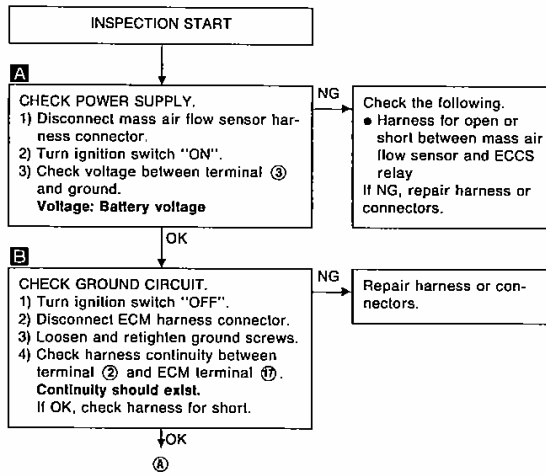
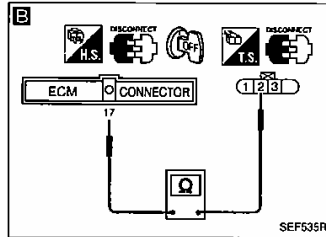
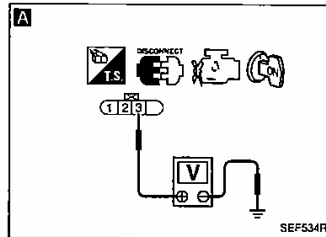

TROUBLE DIAGNOSES

For Europe

Diagnostic Procedure 24 (Cont'd)

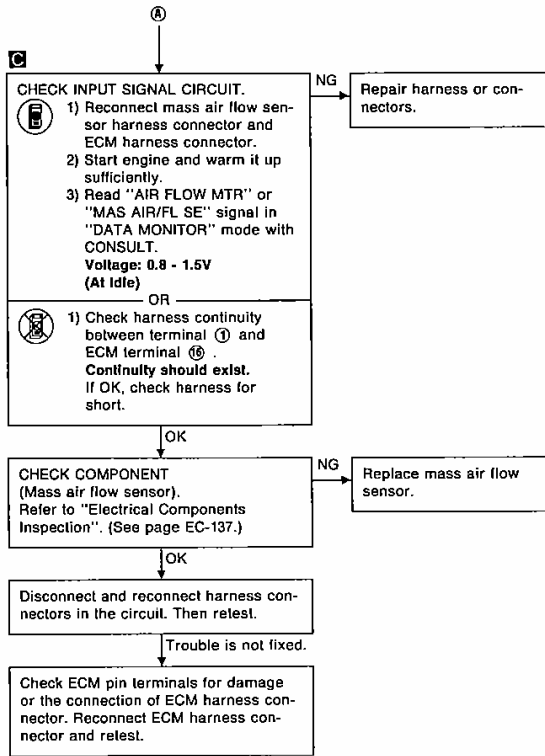
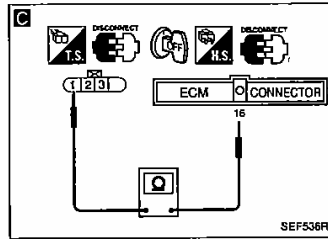
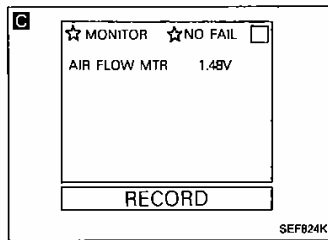

Perform FINAL CHECK by the following procedure after repair is completed.

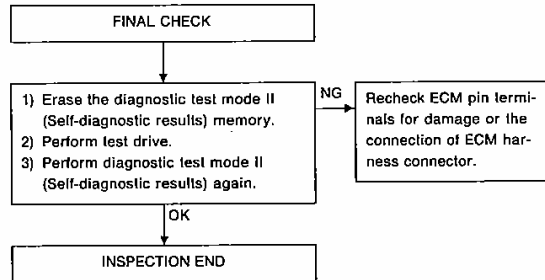

Diagnostic Procedure 25

ENGINE COOLANT TEMPERATURE SENSOR (Diagnostic trouble code No. 13)

EC-ECTS-01

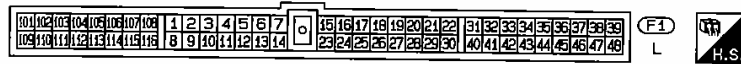
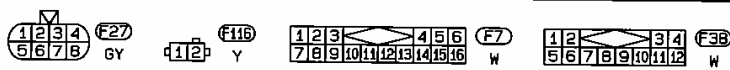
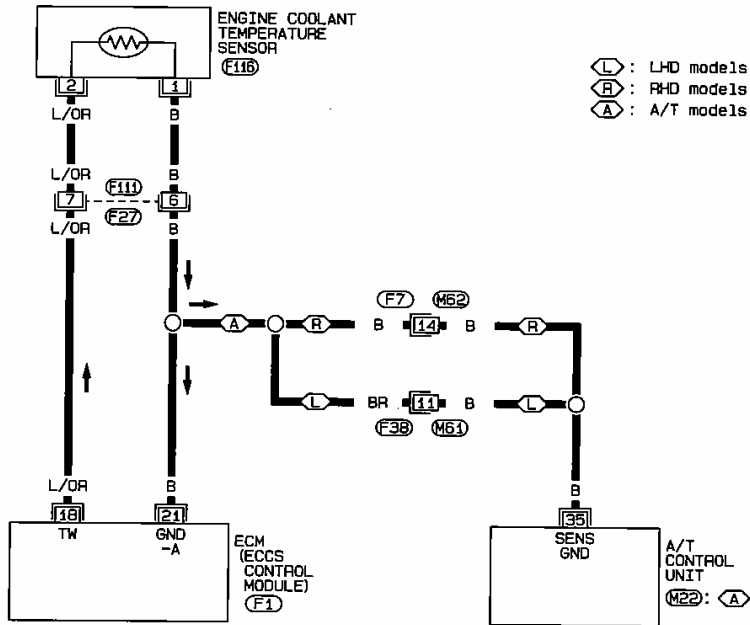

TROUBLE DIAGNOSES

For Europe

Diagnostic Procedure 25 (Cont'd)

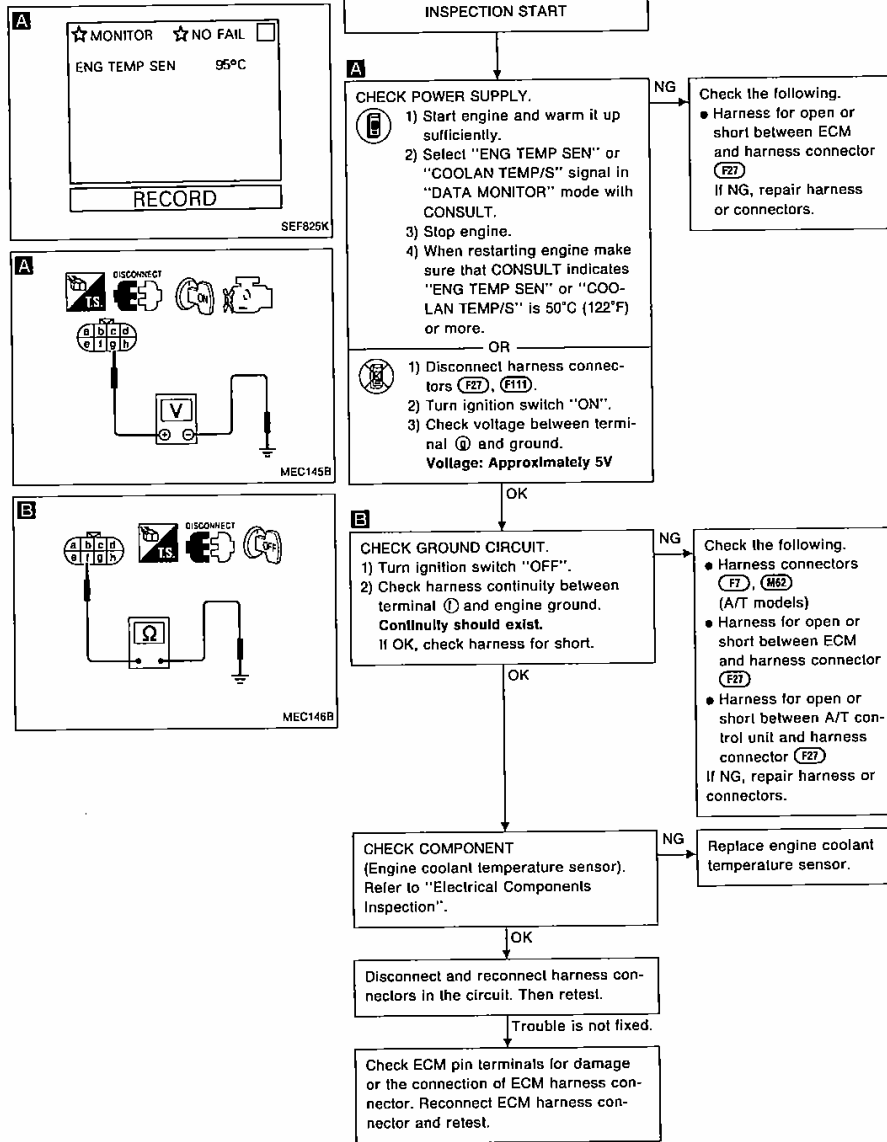

TROUBLE DIAGNOSES

For Europe

Diagnostic Procedure 25 (Cont'd)

Perform **FINAL CHECK** by the following procedure after repair is completed.

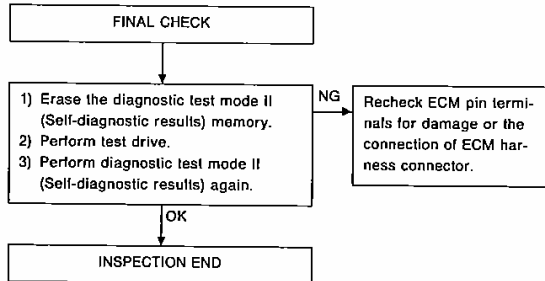

EC

Diagnostic Procedure 26

IGNITION SIGNAL (Diagnostic trouble code No. 21)

LHD MODELS

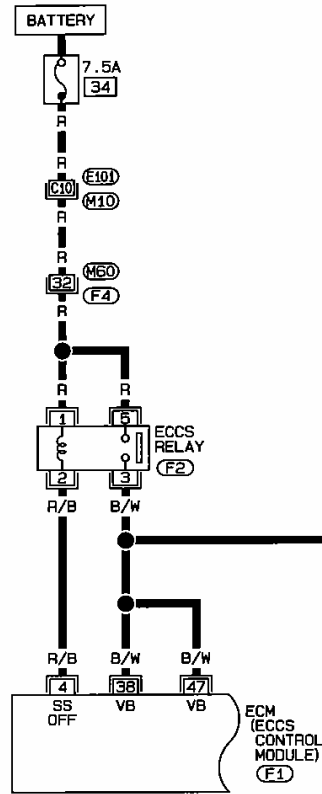

EC-IGN/SG-01

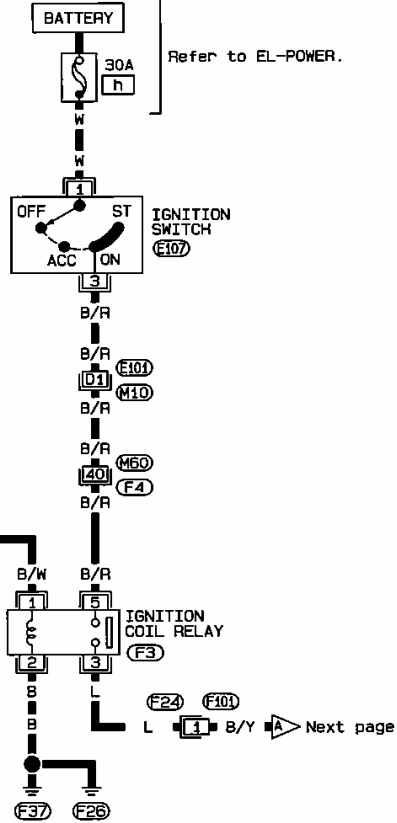

Refer to EL-POWER.

Next page

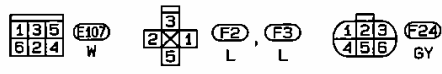

Refer to last page (Foldout page).

- M10, E101
- M60, F4

10	11	12	13	14	15	16	17	18	19	20	21	22	23	24	25	26	27	28	29	30	31	32	33	34	35	36	37	38	39
40	41	42	43	44	45	46	47	48																					



Diagnostic Procedure 26 (Cont'd)

EC-IGN/SG-02

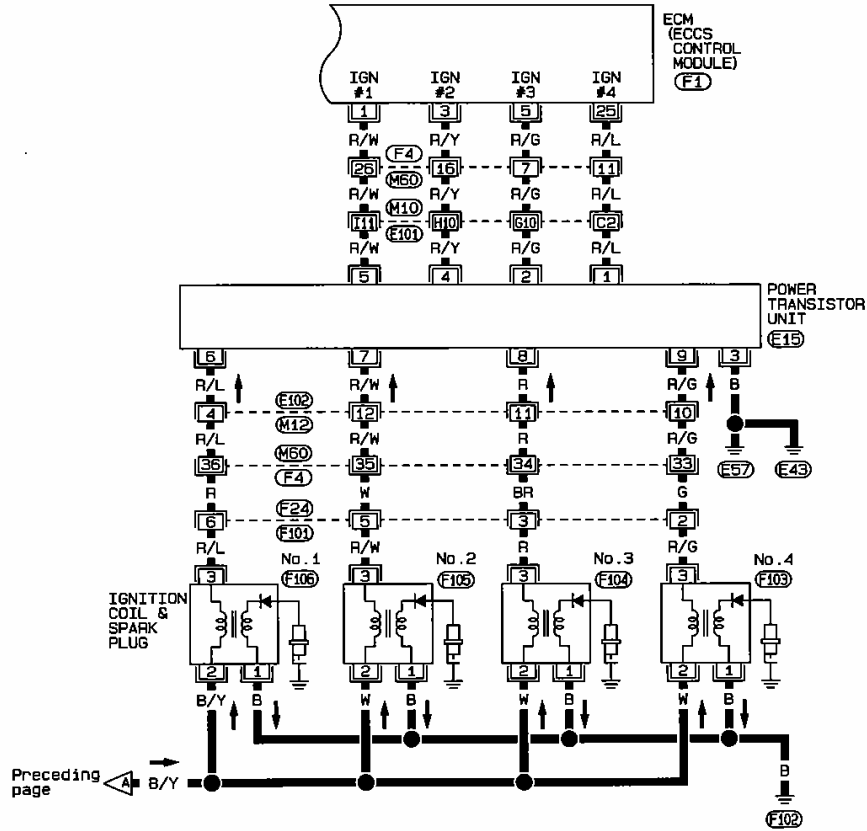

EC

<input checked="" type="checkbox"/> F103, F104, F105, F106 1 2 3 GY GY GY GY	<input checked="" type="checkbox"/> F24 4 5 6 GY	<input checked="" type="checkbox"/> E102 1 2 3 4 5 6 7 8 9 10 11 12 W	Refer to last page (Foldout page).																																																																																																																					
<input checked="" type="checkbox"/> E15 1 2 3 4 5 6 7 8 9 GY GY		<input checked="" type="checkbox"/> M10, E101 <input checked="" type="checkbox"/> M60, F4																																																																																																																						
<table border="1"> <tr> <td>101</td><td>102</td><td>103</td><td>104</td><td>105</td><td>106</td><td>107</td><td>108</td><td>1</td><td>2</td><td>3</td><td>4</td><td>5</td><td>6</td><td>7</td><td>8</td><td>9</td><td>10</td><td>11</td><td>12</td><td>13</td><td>14</td><td>15</td><td>16</td><td>17</td><td>18</td><td>19</td><td>20</td><td>21</td><td>22</td><td>23</td><td>24</td><td>25</td><td>26</td><td>27</td><td>28</td><td>29</td><td>30</td><td>31</td><td>32</td><td>33</td><td>34</td><td>35</td><td>36</td><td>37</td><td>38</td><td>39</td><td>40</td><td>41</td><td>42</td><td>43</td><td>44</td><td>45</td><td>46</td><td>47</td><td>48</td> </tr> <tr> <td>109</td><td>110</td><td>111</td><td>112</td><td>113</td><td>114</td><td>115</td><td>116</td><td>8</td><td>9</td><td>10</td><td>11</td><td>12</td><td>13</td><td>14</td><td>15</td><td>16</td><td>17</td><td>18</td><td>19</td><td>20</td><td>21</td><td>22</td><td>23</td><td>24</td><td>25</td><td>26</td><td>27</td><td>28</td><td>29</td><td>30</td><td>31</td><td>32</td><td>33</td><td>34</td><td>35</td><td>36</td><td>37</td><td>38</td><td>39</td><td>40</td><td>41</td><td>42</td><td>43</td><td>44</td><td>45</td><td>46</td><td>47</td><td>48</td><td>49</td><td>50</td><td>51</td><td>52</td><td>53</td><td>54</td><td>55</td><td>56</td><td>57</td><td>58</td><td>59</td><td>60</td> </tr> </table>			101	102	103	104	105	106	107	108	1	2	3	4	5	6	7	8	9	10	11	12	13	14	15	16	17	18	19	20	21	22	23	24	25	26	27	28	29	30	31	32	33	34	35	36	37	38	39	40	41	42	43	44	45	46	47	48	109	110	111	112	113	114	115	116	8	9	10	11	12	13	14	15	16	17	18	19	20	21	22	23	24	25	26	27	28	29	30	31	32	33	34	35	36	37	38	39	40	41	42	43	44	45	46	47	48	49	50	51	52	53	54	55	56	57	58	59	60	<input checked="" type="checkbox"/> F1 L
101	102	103	104	105	106	107	108	1	2	3	4	5	6	7	8	9	10	11	12	13	14	15	16	17	18	19	20	21	22	23	24	25	26	27	28	29	30	31	32	33	34	35	36	37	38	39	40	41	42	43	44	45	46	47	48																																																																	
109	110	111	112	113	114	115	116	8	9	10	11	12	13	14	15	16	17	18	19	20	21	22	23	24	25	26	27	28	29	30	31	32	33	34	35	36	37	38	39	40	41	42	43	44	45	46	47	48	49	50	51	52	53	54	55	56	57	58	59	60																																																												

Diagnostic Procedure 26 (Cont'd)

RHD MODELS

EC-IGN/SG-03

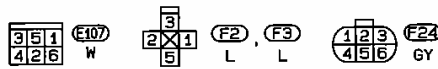
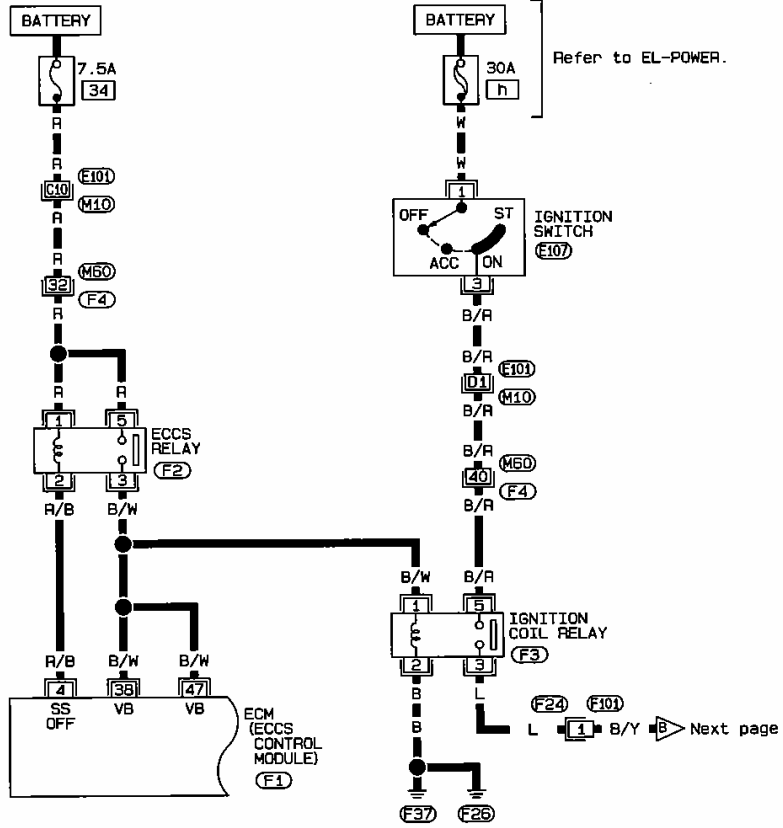

Refer to last page (Foldout page).

M10, E101
M50, F4



F1
L



Diagnostic Procedure 26 (Cont'd)

EC-IGN/SG-04

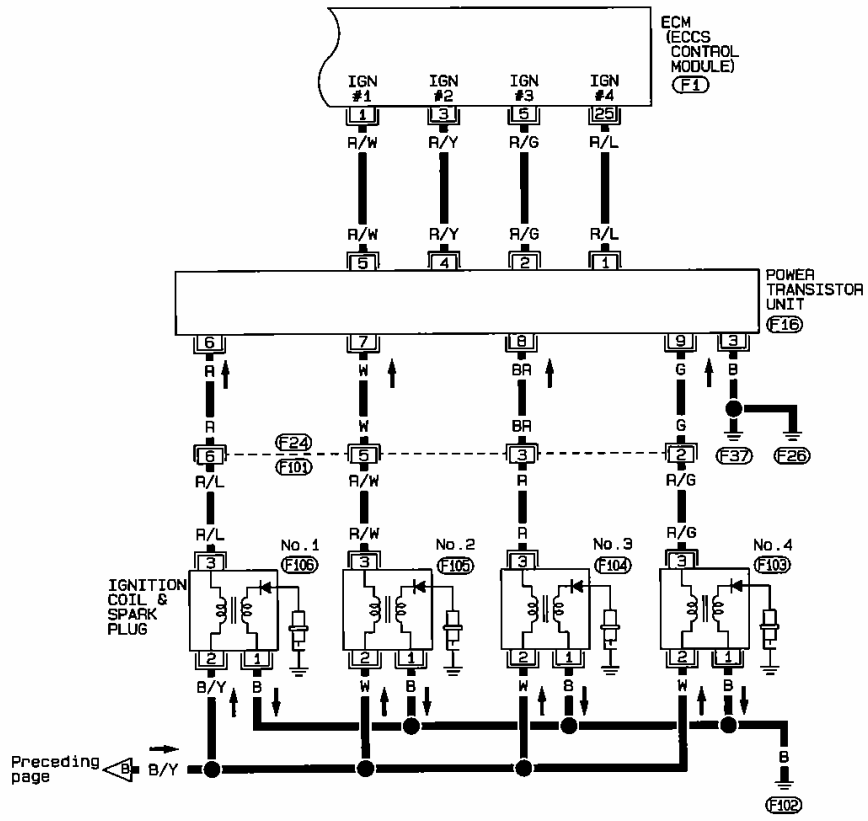

EC

Preceding page → B/Y

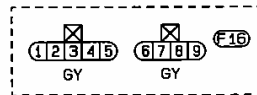
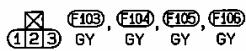
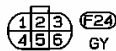

101	102	103	104	105	106	1	2	3	4	5	6	7	8	9	10	11	12	13	14	15	16	17	18	19	20	21	22	23	24	25	26	27	28	29	30	31	32	33	34	35	36	37	38	39	40	41	42	43	44	45	46	47	48
-----	-----	-----	-----	-----	-----	---	---	---	---	---	---	---	---	---	----	----	----	----	----	----	----	----	----	----	----	----	----	----	----	----	----	----	----	----	----	----	----	----	----	----	----	----	----	----	----	----	----	----	----	----	----	----	----



TROUBLE DIAGNOSES

For Europe

Diagnostic Procedure 26 (Cont'd)

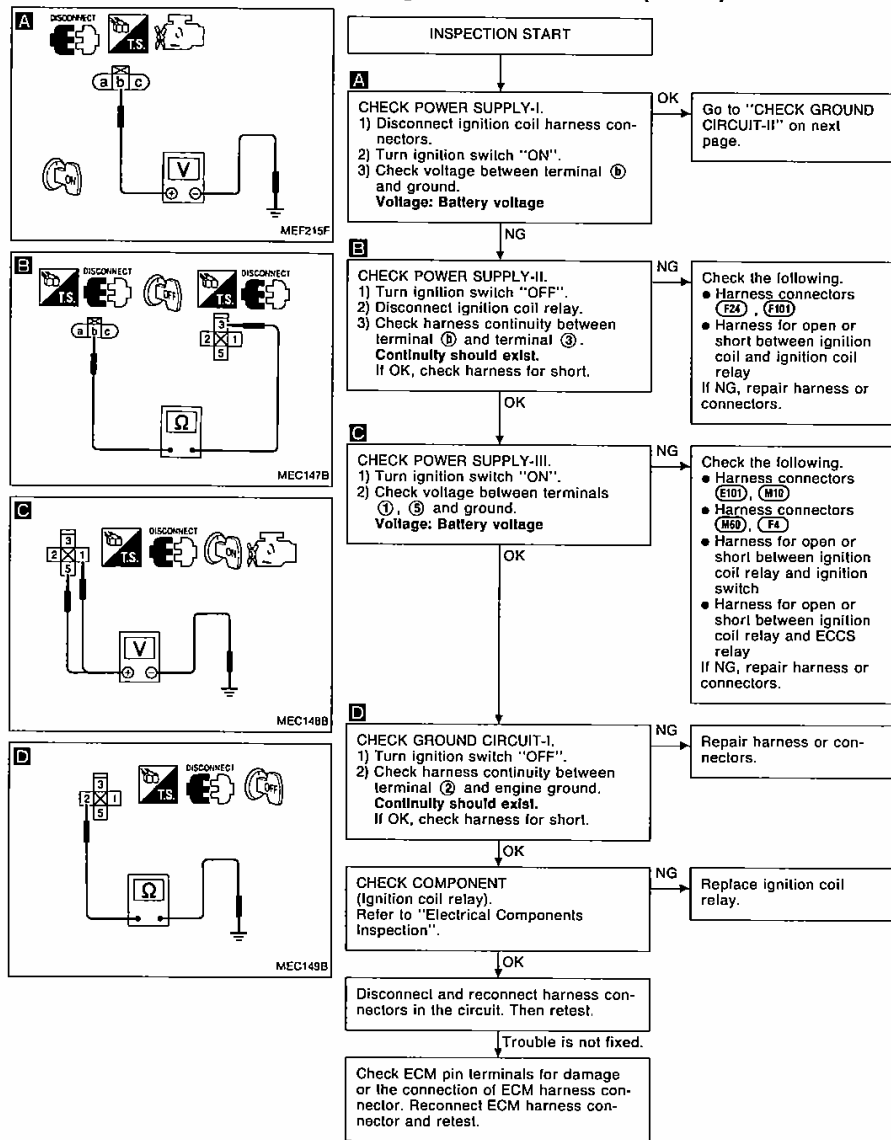

TROUBLE DIAGNOSES

For Europe

Diagnostic Procedure 26 (Cont'd)

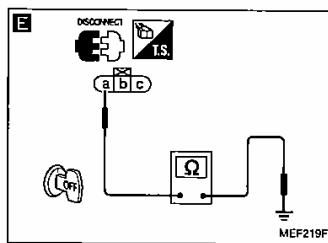

CHECK GROUND CIRCUIT-II.
 1) Turn ignition switch "OFF".
E 2) Check harness continuity between terminal (a) and engine ground.
Continuity should exist.
 If OK, check harness for short.
 3) Disconnect power transistor unit harness connector.
F 4) Check harness continuity between terminal (1) and engine ground.
Continuity should exist.
 If OK, check harness for short.

NG → Repair harness or connectors.

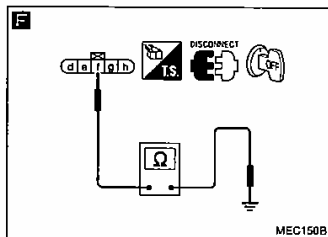

CHECK OUTPUT SIGNAL CIRCUIT.
G 1) Check harness continuity between terminals (1), (1), (1), (1) and terminal (c).
Continuity should exist.
 If OK, check harness for short.
 2) Disconnect ECM harness connector.
H 3) Check harness continuity between following terminals.
 (1) - (1) (3) - (3)
 (3) - (1) (5) - (4)
Continuity should exist.
 If OK, check harness for short.

NG → Check the following.
 • Harness connectors (F2), (F1B)
 • Harness connectors (M5), (F4) (LHD models)
 • Harness connectors (E10), (M12) (LHD models)
 • Harness connectors (M10), (E11) (LHD models)
 • Harness for open or short between ignition coil and power transistor unit
 • Harness for open or short between ECM and power transistor unit
 If NG, repair harness or connectors.

EC

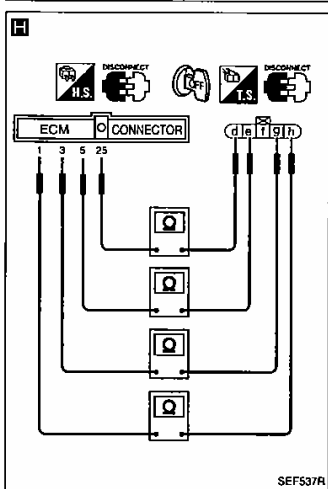
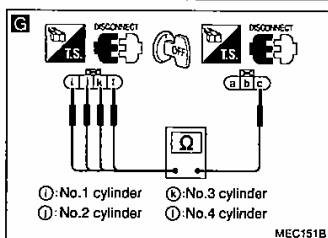

CHECK COMPONENTS (Ignition coil and power transistor unit). Refer to "Electrical Components Inspection".

NG → Replace malfunctioning component(s).

OK → Disconnect and reconnect harness connectors in the circuit. Then retest.

Trouble is not fixed. → Check ECM pin terminals for damage or the connection of ECM harness connector. Reconnect ECM harness connector and retest.

TROUBLE DIAGNOSES

For Europe

Diagnostic Procedure 26 (Cont'd)

Perform **FINAL CHECK** by the following procedure after repair is completed.

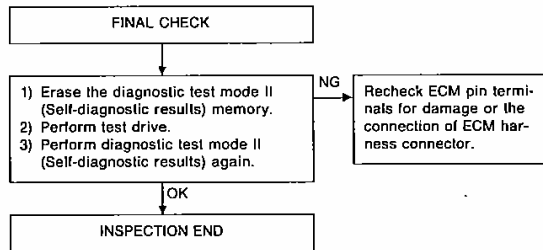

Diagnostic Procedure 28

KNOCK SENSOR (Diagnostic trouble code No. 34)

EC-KS-01

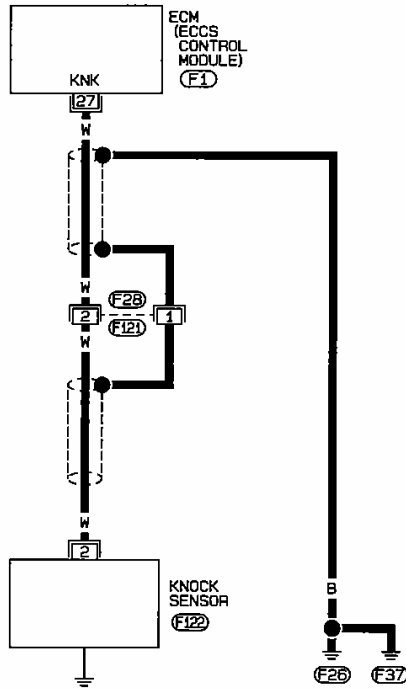

EC

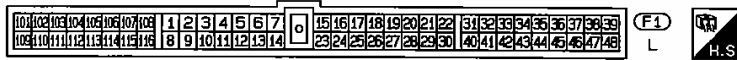
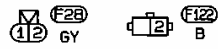

TROUBLE DIAGNOSES

For Europe

Diagnostic Procedure 28 (Cont'd)

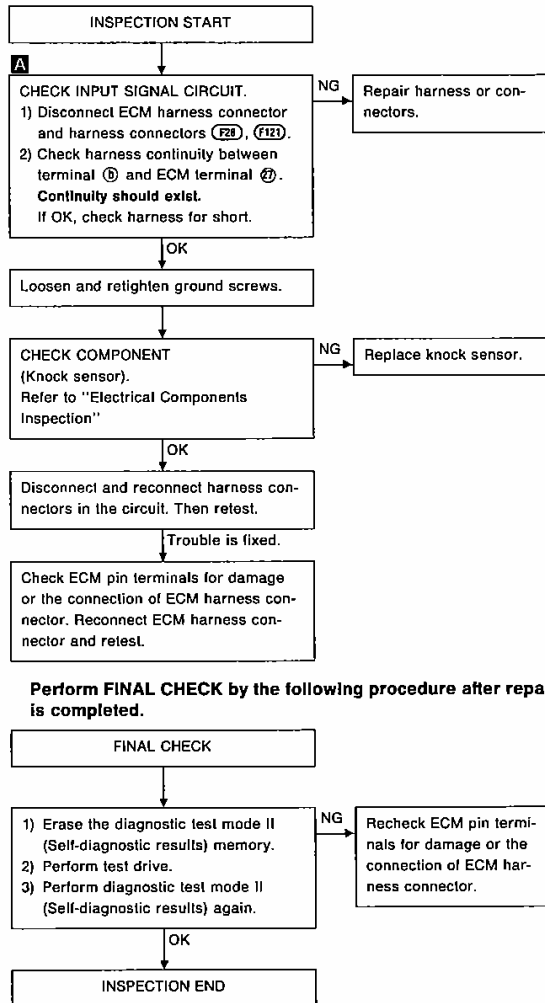
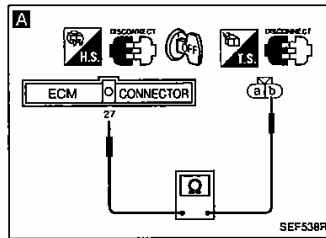

Diagnostic Procedure 29

THROTTLE POSITION SENSOR (Diagnostic trouble code No. 43)

EC-TPS-01

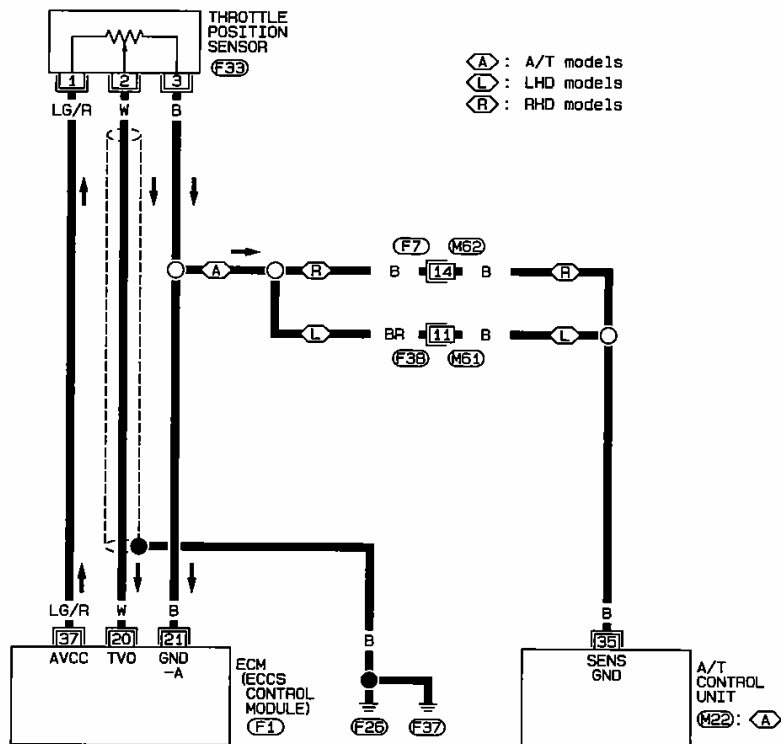

EC

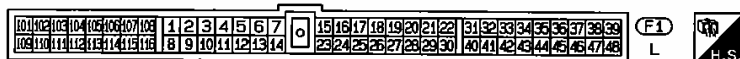
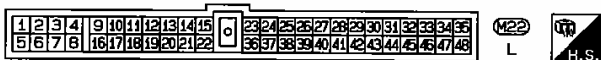
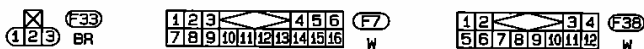

TROUBLE DIAGNOSES

For Europe

Diagnostic Procedure 29 (Cont'd)

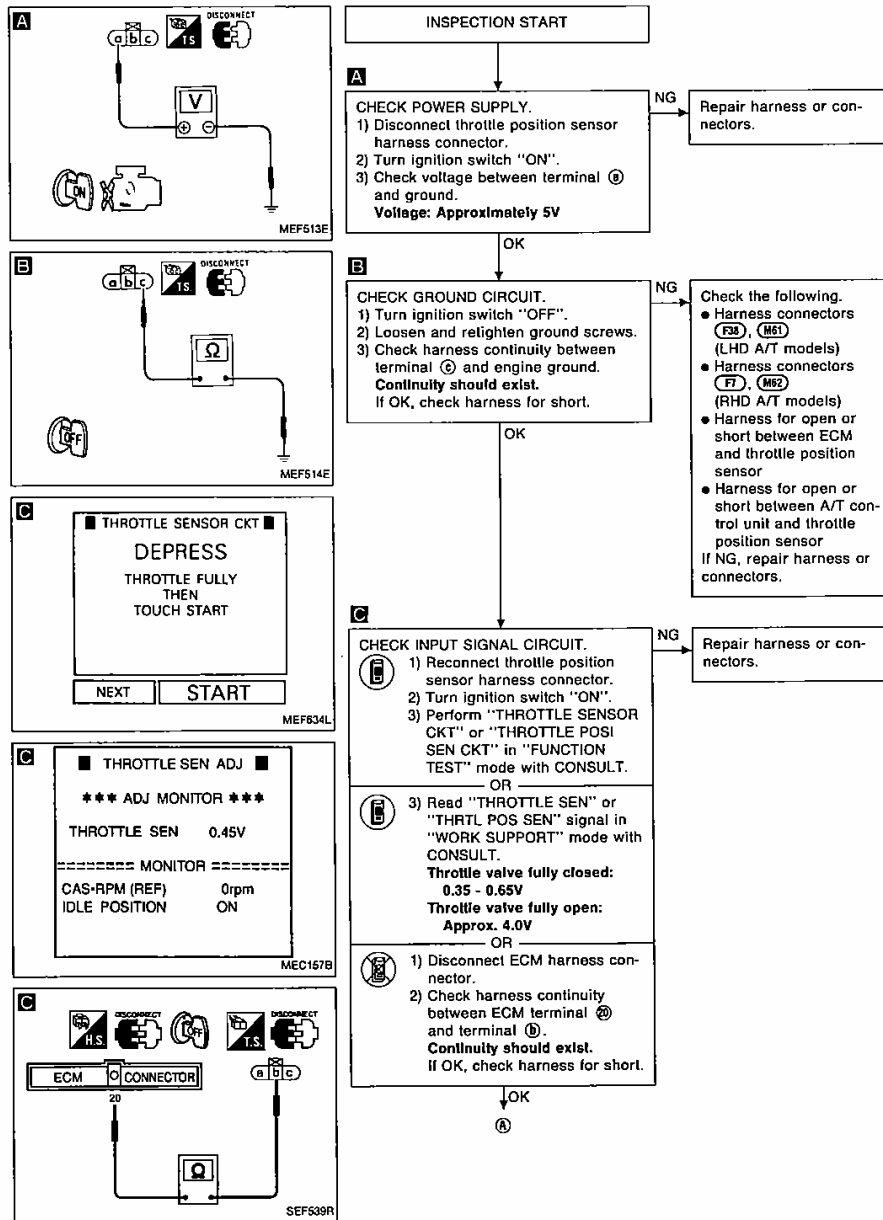

TROUBLE DIAGNOSES

For Europe

Diagnostic Procedure 29 (Cont'd)

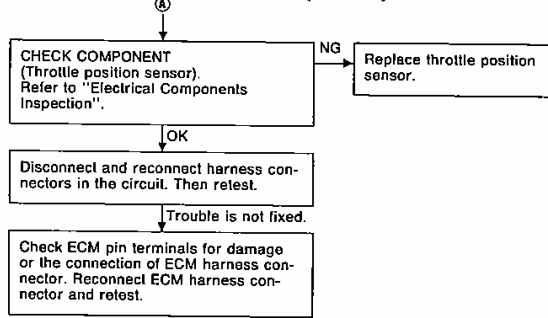

EC

Perform FINAL CHECK by the following procedure after repair is completed.

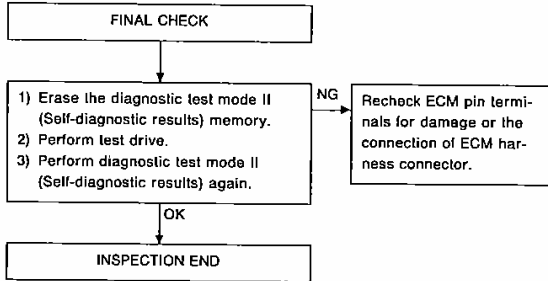

Diagnostic Procedure 30

A/T CONTROL (Diagnostic trouble code No. 54)

EC-AT/C-01

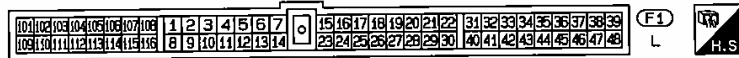
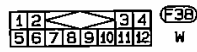
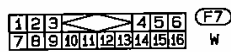
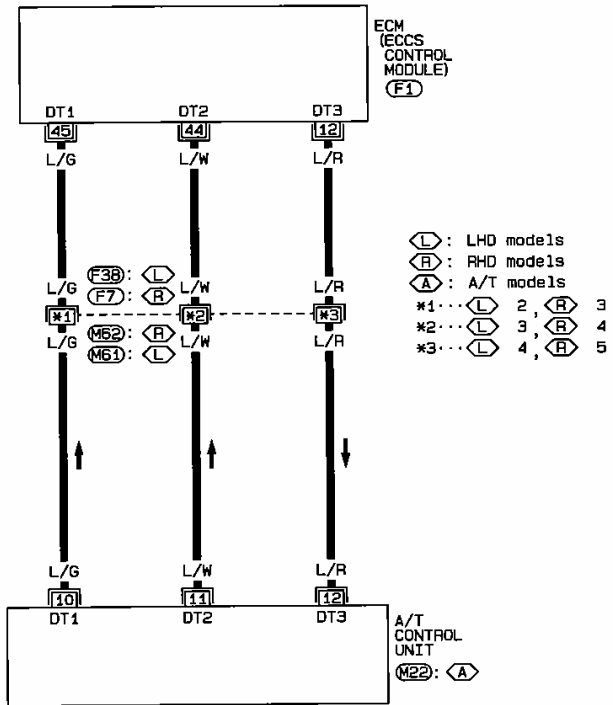

TROUBLE DIAGNOSES

For Europe

Diagnostic Procedure 30 (Cont'd)

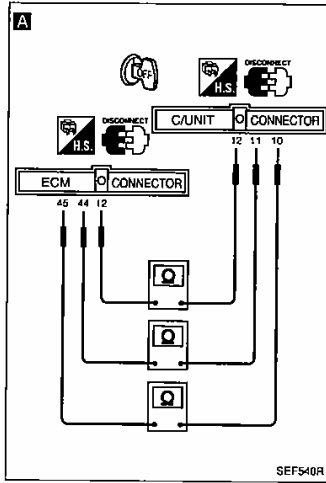

SEF540R

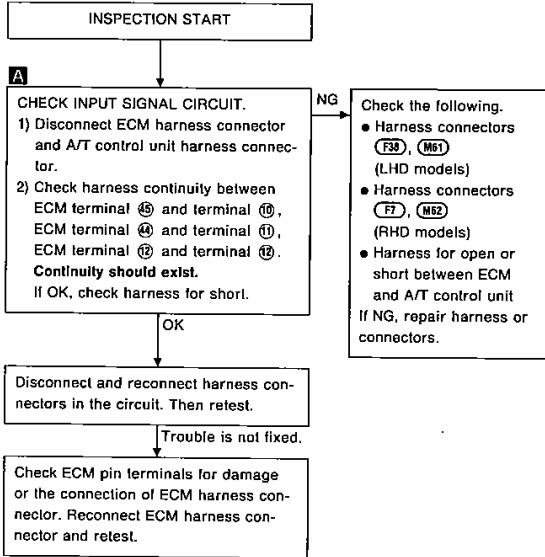

EC

Perform FINAL CHECK by the following procedure after repair is completed.

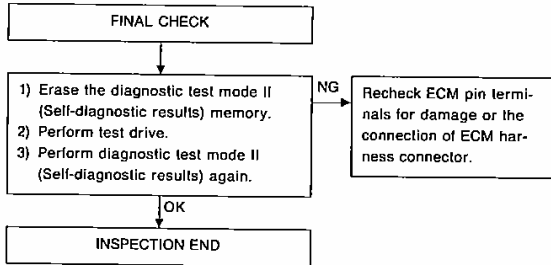

Diagnostic Procedure 31

START SIGNAL (Not self-diagnostic item)

EC-S/SIG-01

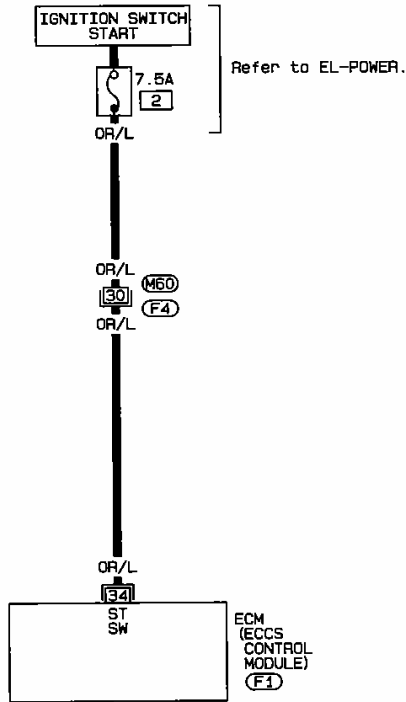

Refer to last page (Foldout page).

(M60), (F4)

101	102	103	104	105	106	107	108	1	2	3	4	5	6	7	15	16	17	18	19	20	21	22	31	32	33	34	35	36	37	38	39
109	110	111	112	113	114	115	116	8	9	10	11	12	13	14	23	24	25	26	27	28	29	30	40	41	42	43	44	45	46	47	48

(F1)
L



TROUBLE DIAGNOSES

For Europe

Diagnostic Procedure 31 (Cont'd)

Harness layout

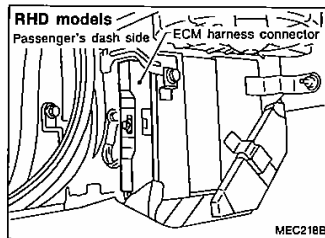
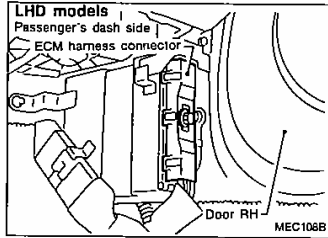

EC

A

■ START SIGNAL CKT ■

1. CLOSE THROTTLE, SHIFT TO P OR N RANGE.
2. TOUCH START AND START ENGINE IMMEDIATELY.

NEXT START

MEF481B

A

☆ MONITOR ☆ NO FAIL

START SIGNAL	OFF
IDLE POSITION	ON
AIR COND SIG	OFF
NEUTRAL SW	ON

RECORD

SEF384J

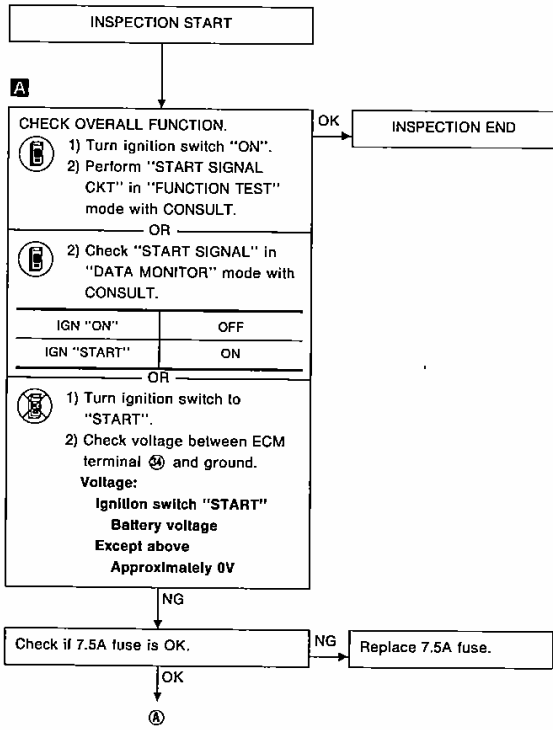
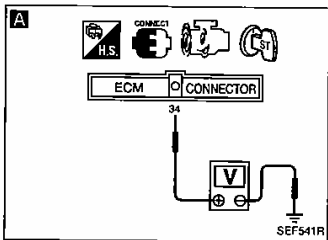

TROUBLE DIAGNOSES

For Europe

Diagnostic Procedure 31 (Cont'd)

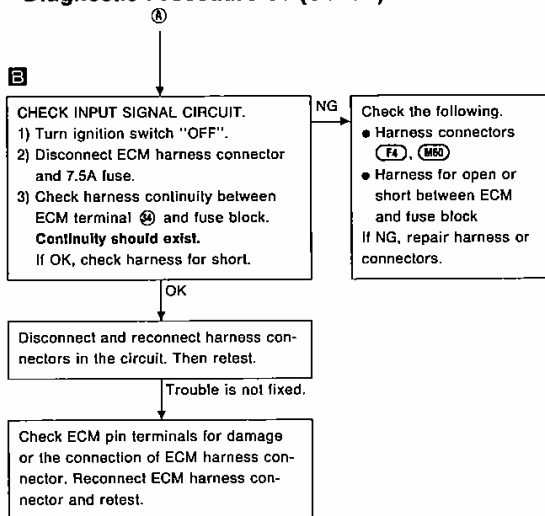
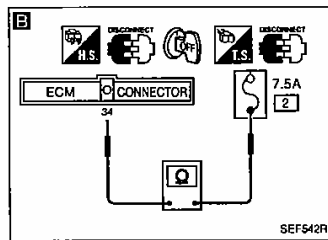

Diagnostic Procedure 32

VEHICLE SPEED SENSOR (Not self-diagnostic item)

EC-VSS-01

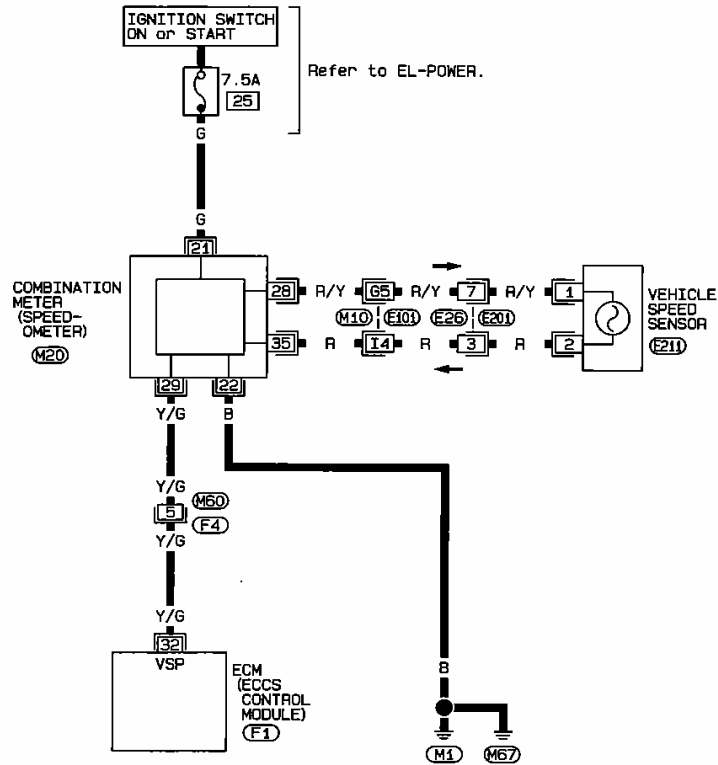

EC

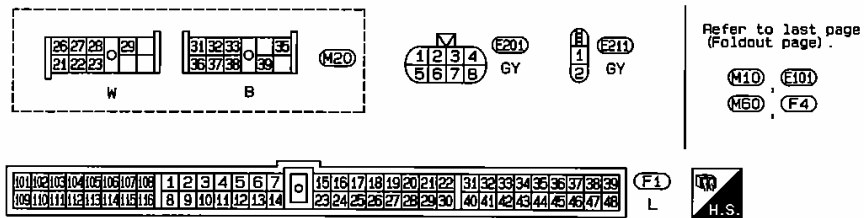

Diagnostic Procedure 32 (Cont'd)

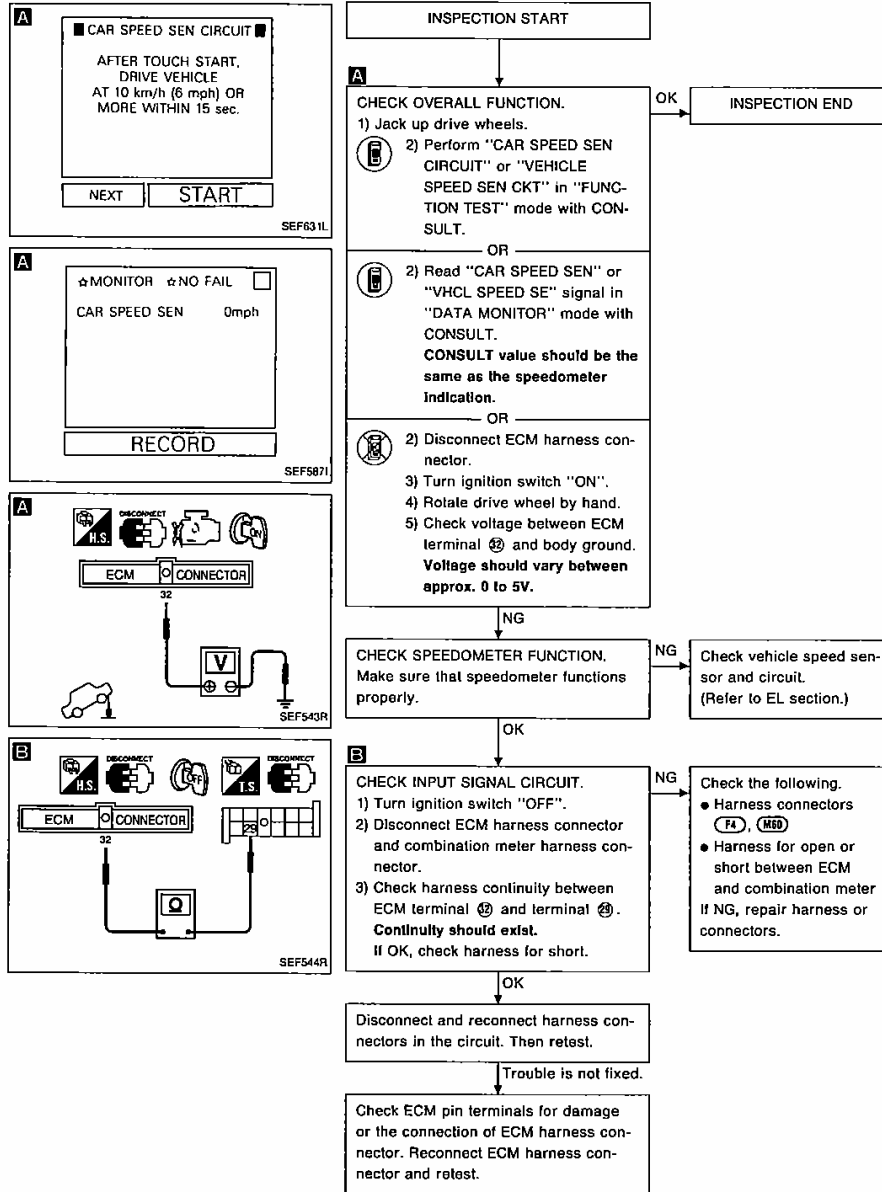

Diagnostic Procedure 33

EGR AND CANISTER CONTROL (Not self-diagnostic item)

EC-EGRC/V-01

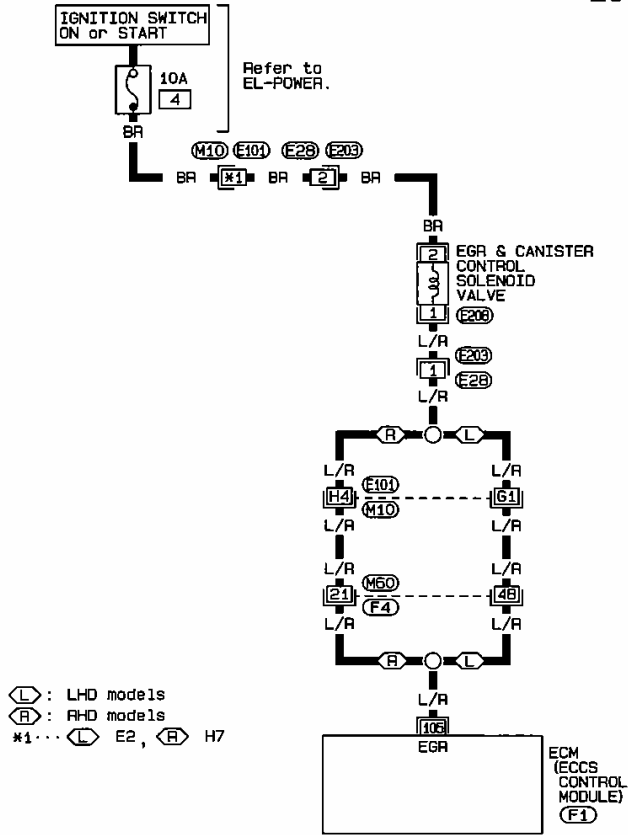

EC

◁ : LHD models
 ▷ : RHD models
 #1... ◁ E2, ▷ H7

⊗ E206 B ⊙ E203 BY

Refer to last page (Foldout page).

M10, E101
 M50, F4

10	11	12	13	14	15	16	17	18	19	20	21	22	23	24	25	26	27	28	29	30	31	32	33	34	35	36	37	38	39
40	41	42	43	44	45	46	47	48																					

F1
 L



Diagnostic Procedure 33 (Cont'd)

Harness layout

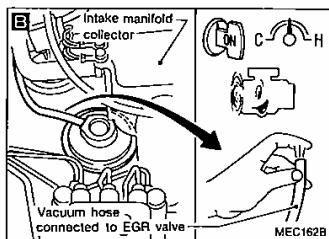
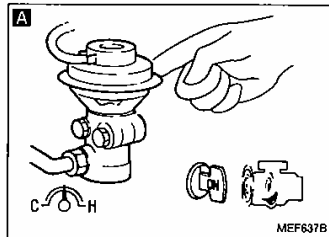
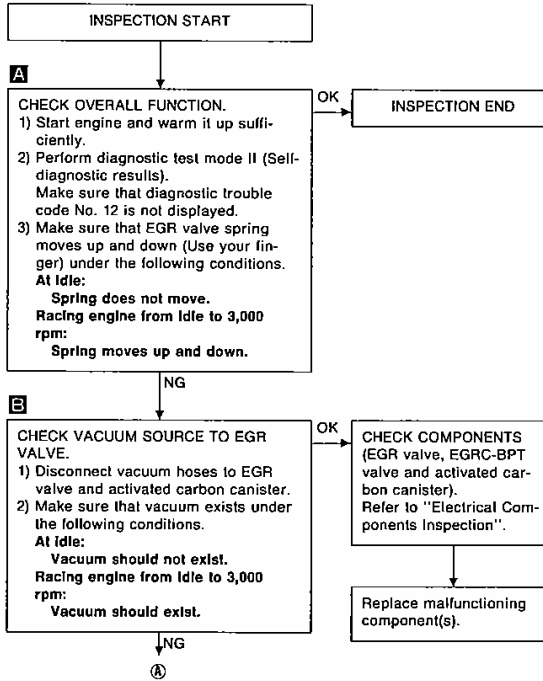
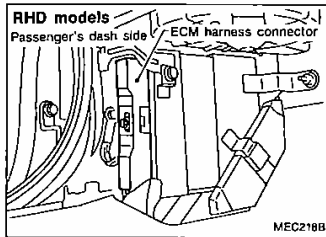
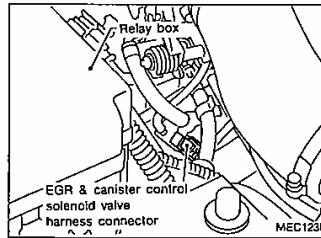
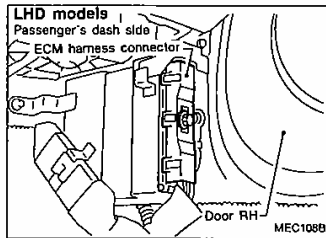

Diagnostic Procedure 33 (Cont'd)

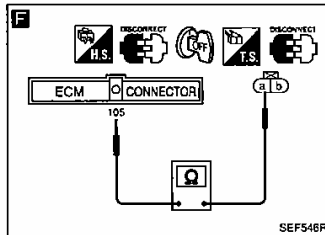
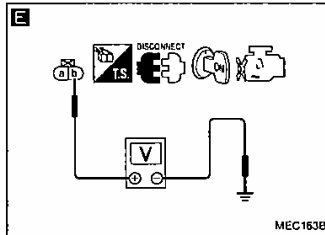
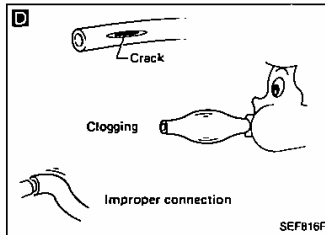
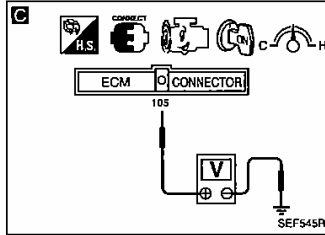
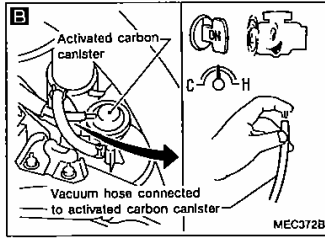

C
CHECK CONTROL FUNCTION.
 1) Check voltage between ECM terminal **(105)** and ground under the following conditions.
Voltage:
 At Idle
 Approximately 0V
 Engine speed is 2,000 rpm
 Battery voltage

D
CHECK VACUUM HOSE.
 1) Check vacuum hose for clogging, cracks and proper connection.

E
CHECK POWER SUPPLY.
 1) Stop engine.
 2) Disconnect EGR & canister control solenoid valve harness connector.
 3) Turn ignition switch "ON".
 4) Check voltage between terminal **(105)** and ground.
Voltage: Battery voltage

Check the following.

- Harness connectors **(M10), (E101)**
- Harness connectors **(E22), (E203)**
- 10A fuse
- Harness for open or short between EGR & canister control solenoid valve and fuse

If NG, repair harness or connectors.

F
CHECK OUTPUT SIGNAL CIRCUIT.
 1) Turn ignition switch "OFF".
 2) Disconnect ECM harness connector.
 3) Check harness continuity between ECM terminal **(105)** and terminal **(105)**.
Continuity should exist.
 If OK, check harness for short.

Check the following.

- Harness connectors **(E203), (E22)**
- Harness connectors **(E101), (M10)**
- Harness connectors **(M50), (F1)** (RHD models)
- Harness connectors **(M52), (F7)** (LHD models)
- Harness for open or short between ECM and EGR & canister control solenoid valve

If NG, repair harness or connectors.

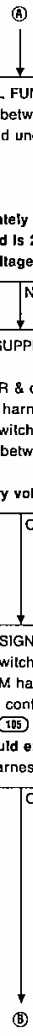

EC

TROUBLE DIAGNOSES

For Europe

Diagnostic Procedure 33 (Cont'd)

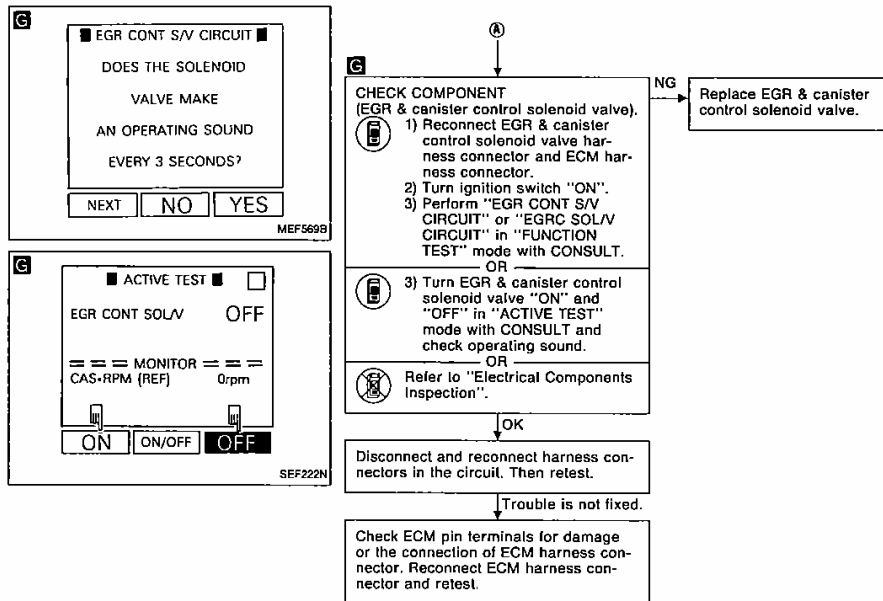

Diagnostic Procedure 34

HEATED OXYGEN SENSOR (Not self-diagnostic item)

EC-H02S-01

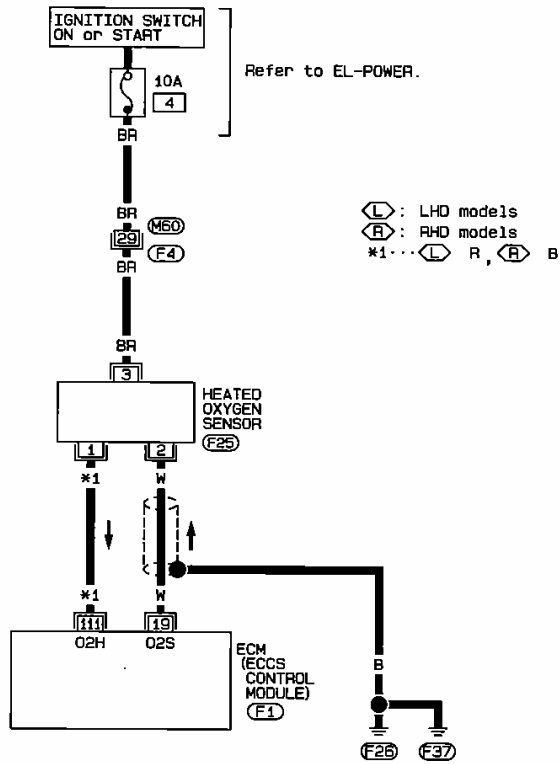

EC

123 F25
GY

Refer to last page
(Foldout page).

M60, F4

01	02	03	04	05	06	07	08	1	2	3	4	5	6	7	0	15	16	17	18	19	20	21	22	31	32	33	34	35	36	37	38	39
09	10	11	12	13	14	15	16	8	9	10	11	12	13	14		23	24	25	26	27	28	29	30	40	41	42	43	44	45	46	47	48

F1
L



TROUBLE DIAGNOSES

For Europe

Diagnostic Procedure 34 (Cont'd)

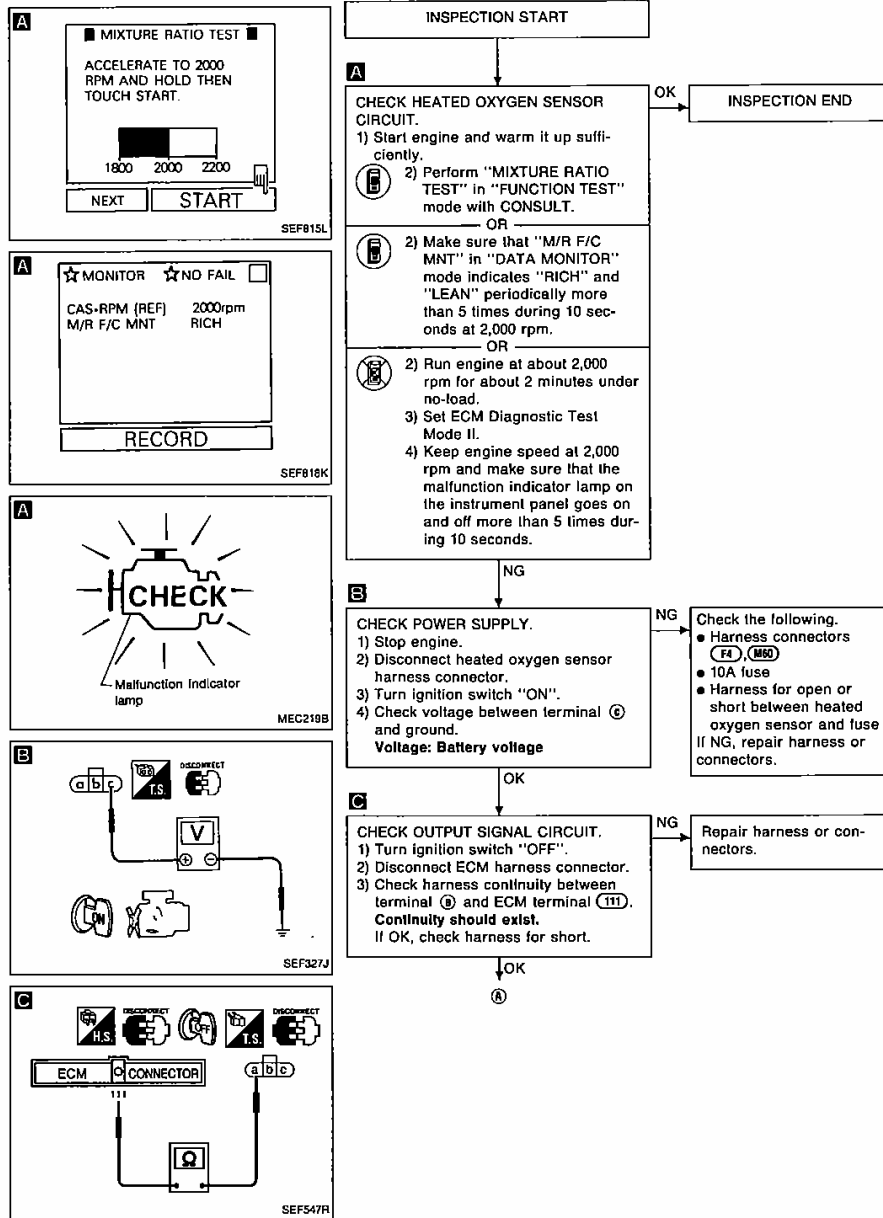

TROUBLE DIAGNOSES

For Europe

Diagnostic Procedure 34 (Cont'd)

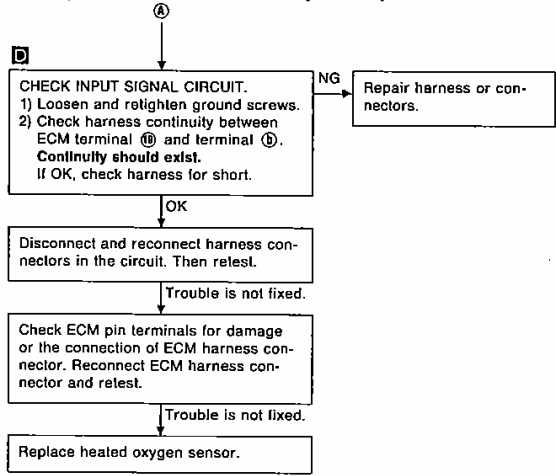
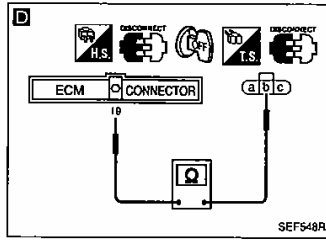

EC

Diagnostic Procedure 35

INJECTOR CIRCUIT (Not self-diagnostic item)

EC-INJECT-01

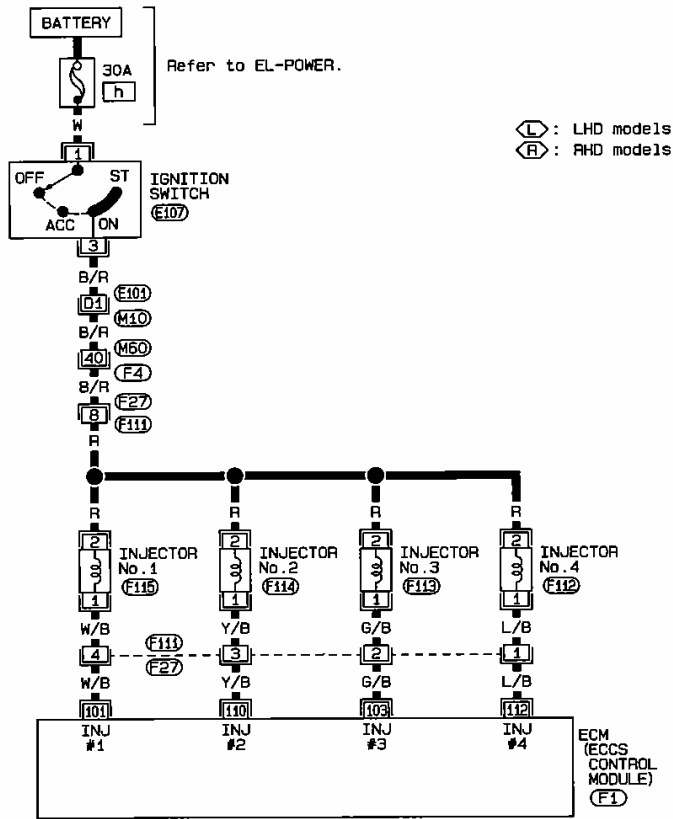

(L) : LHD models
(R) : RHD models

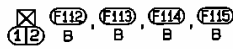
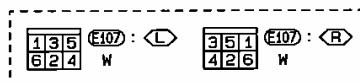

Refer to last page (Foldout page).

(M10) (E101)
(M60) (F4)

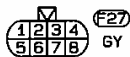

Diagnostic Procedure 35 (Cont'd)

Harness layout

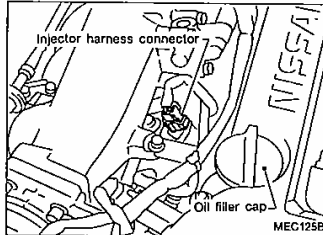
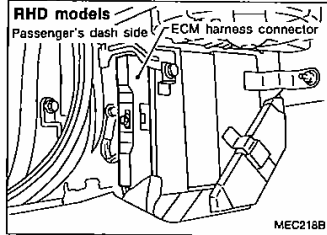
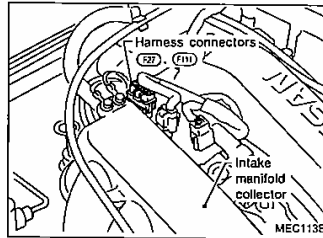
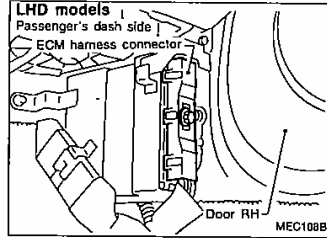

EC

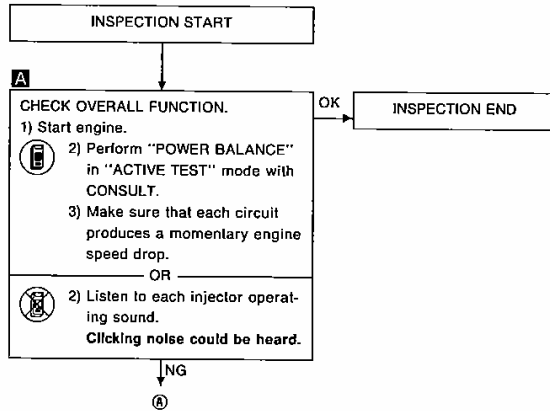
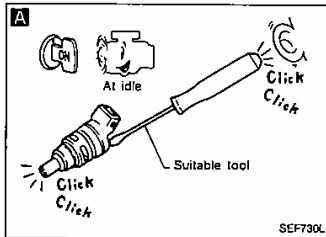
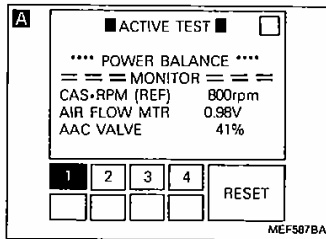

TROUBLE DIAGNOSES

For Europe

Diagnostic Procedure 35 (Cont'd)

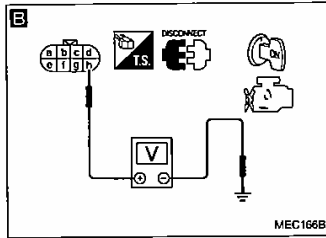

B

CHECK POWER SUPPLY.

- 1) Stop engine.
- 2) Disconnect harness connectors (F27), (F11).
- 3) Turn ignition switch "ON".
- 4) Check voltage between terminal ① and ground.

Voltage: Battery voltage

NG

Check the following.

- Harness connectors (F27), (F11)
- Harness connectors (F4), (M60)
- Harness connectors (M12), (E10)
- Harness for open or short between ignition switch and harness connector (F27)

If NG, repair harness or connectors.

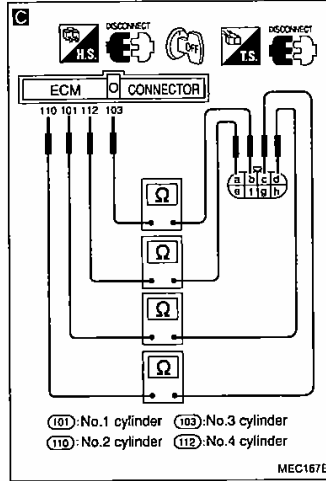

C

CHECK OUTPUT SIGNAL CIRCUIT.

- 1) Turn ignition switch "OFF".
- 2) Disconnect ECM harness connector.
- 3) Check harness continuity between ECM terminal (101) and terminal ①, ECM terminal (110) and terminal ②, ECM terminal (103) and terminal ③, ECM terminal (112) and terminal ④.

Continuity should exist.

If OK, check harness for short.

NG

Check the following.

- Harness connectors (F27), (F11)
- Harness for open or short between ECM and harness connector (F27)

If NG, repair harness or connectors.

OK

CHECK COMPONENT (Injector).

Refer to "Electrical Components Inspection".

NG

Replace injector.

OK

Disconnect and reconnect harness connectors in the circuit. Then retest.

Trouble is not fixed.

Check ECM pin terminals for damage or the connection of ECM harness connector. Reconnect ECM harness connector and retest.

Diagnostic Procedure 36

FUEL PUMP (Not self-diagnostic item)

EC-F/PUMP-01

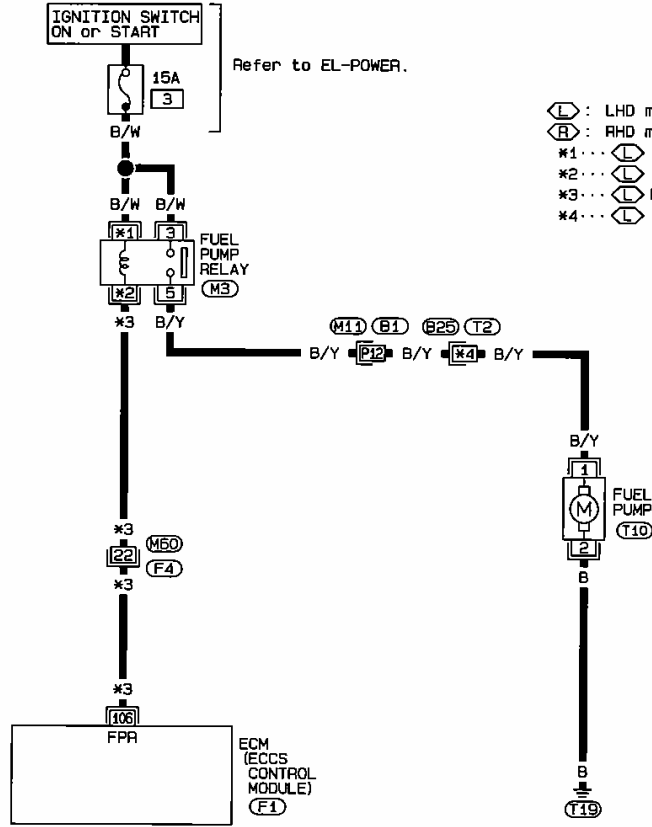

Refer to EL-POWER.

- ◻: LHD models
- ◻: RHD models
- *1... ◻ 1, ◻ 2
- *2... ◻ 2, ◻ 1
- *3... ◻ B/P, ◻ B/Y
- *4... ◻ 1, ◻ 3

EC

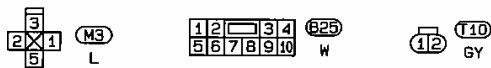

Refer to last page (Foldout page).

- M11, B1
- M60, F4



F1 L



TROUBLE DIAGNOSES

For Europe

Diagnostic Procedure 36 (Cont'd)

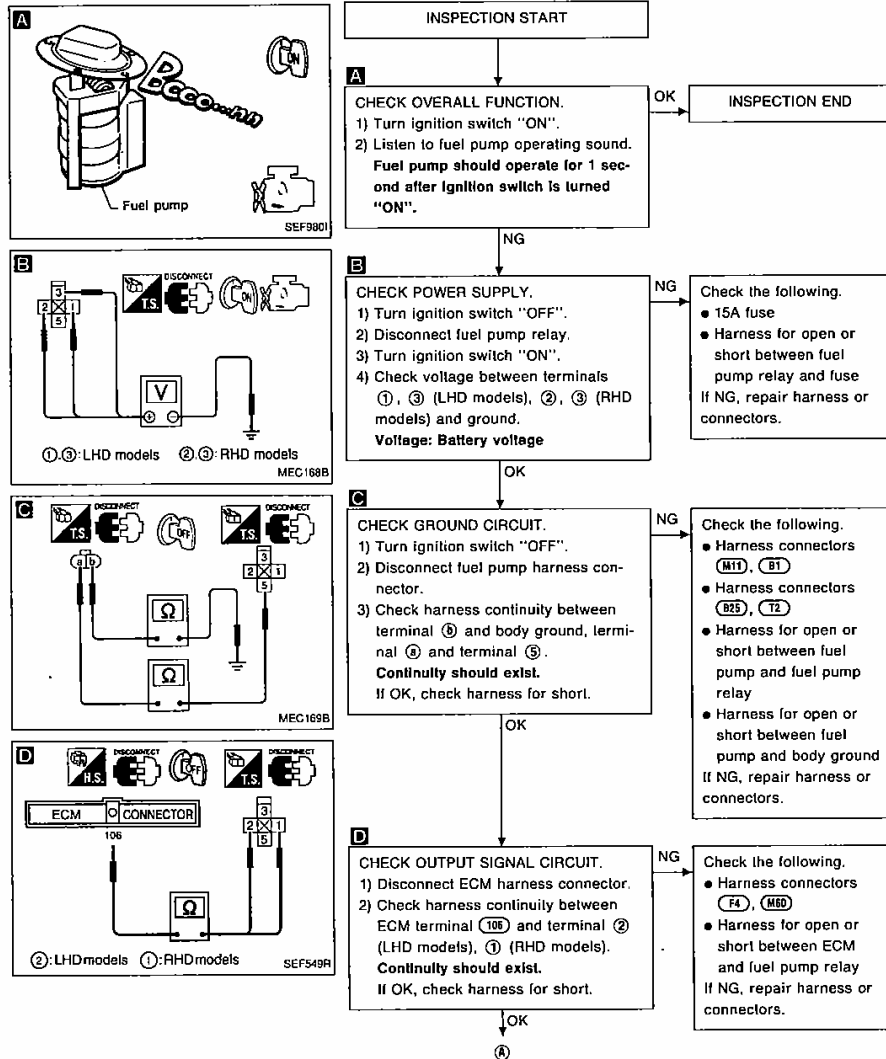

TROUBLE DIAGNOSES

For Europe

Diagnostic Procedure 36 (Cont'd)

E

■ FUEL PUMP CIRCUIT ■
 PINCH FUEL FEED HOSE WITH FINGERS. IS THERE ANY PRESSURE PULSATION ON THE FUEL FEED HOSE?
 OR
 DOES THE FUEL PUMP RELAY MAKE AN OPERATING SOUND EVERY 3 SECONDS?

NEXT NO YES

SEF194L

E

■ ACTIVE TEST ■

FUEL PUMP RELAY ON

== MONITOR ==
 CAS-RPM (REF) 0rpm

ON ON/OFF OFF

SEF498L

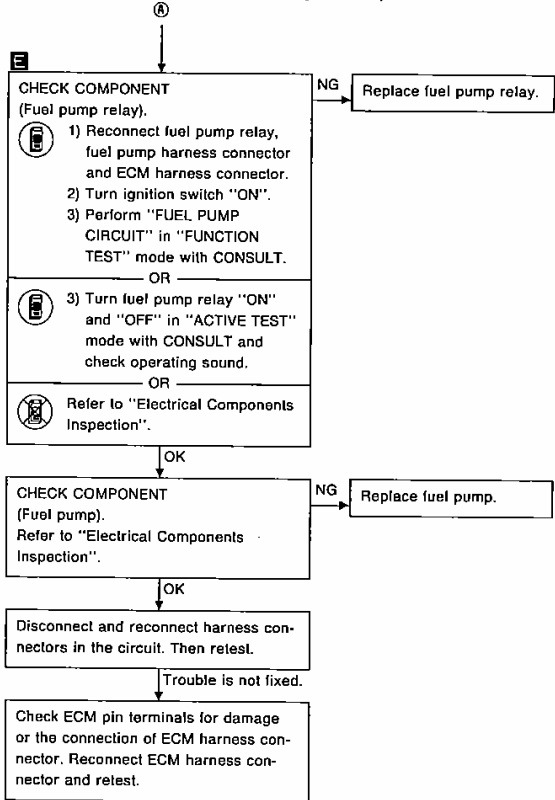

EC

Diagnostic Procedure 37

WASTEGATE VALVE CONTROL (Not self-diagnostic item)

EC-WG/V-01

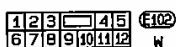
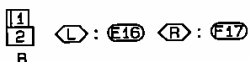
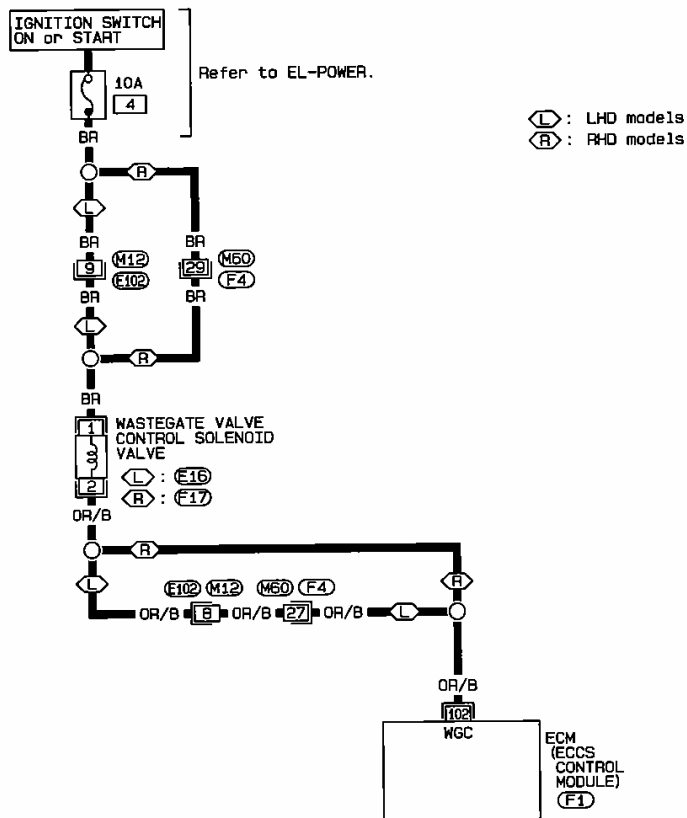

Refer to last page (Foldout page).
M60, F4

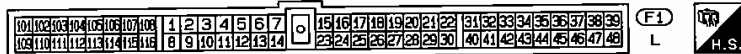

Diagnostic Procedure 37 (Cont'd)

Harness layout

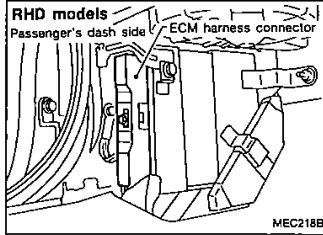
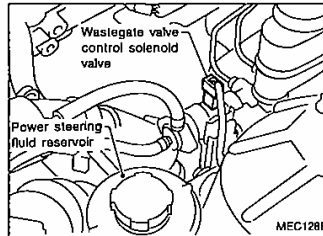
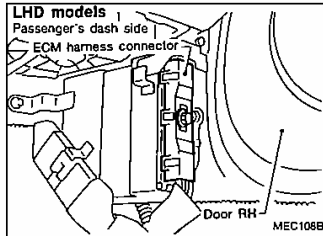

EC

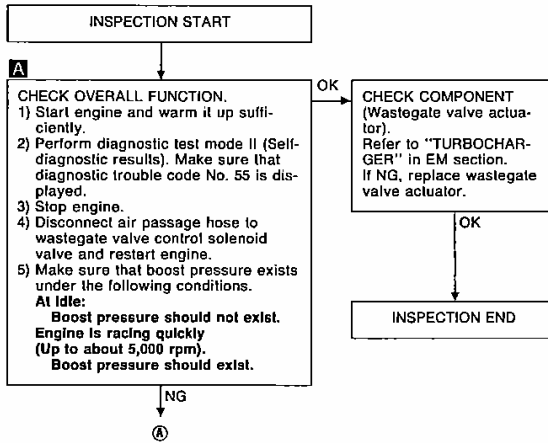
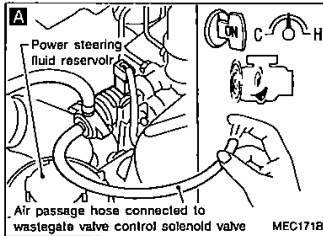

TROUBLE DIAGNOSES

For Europe

Diagnostic Procedure 37 (Cont'd)

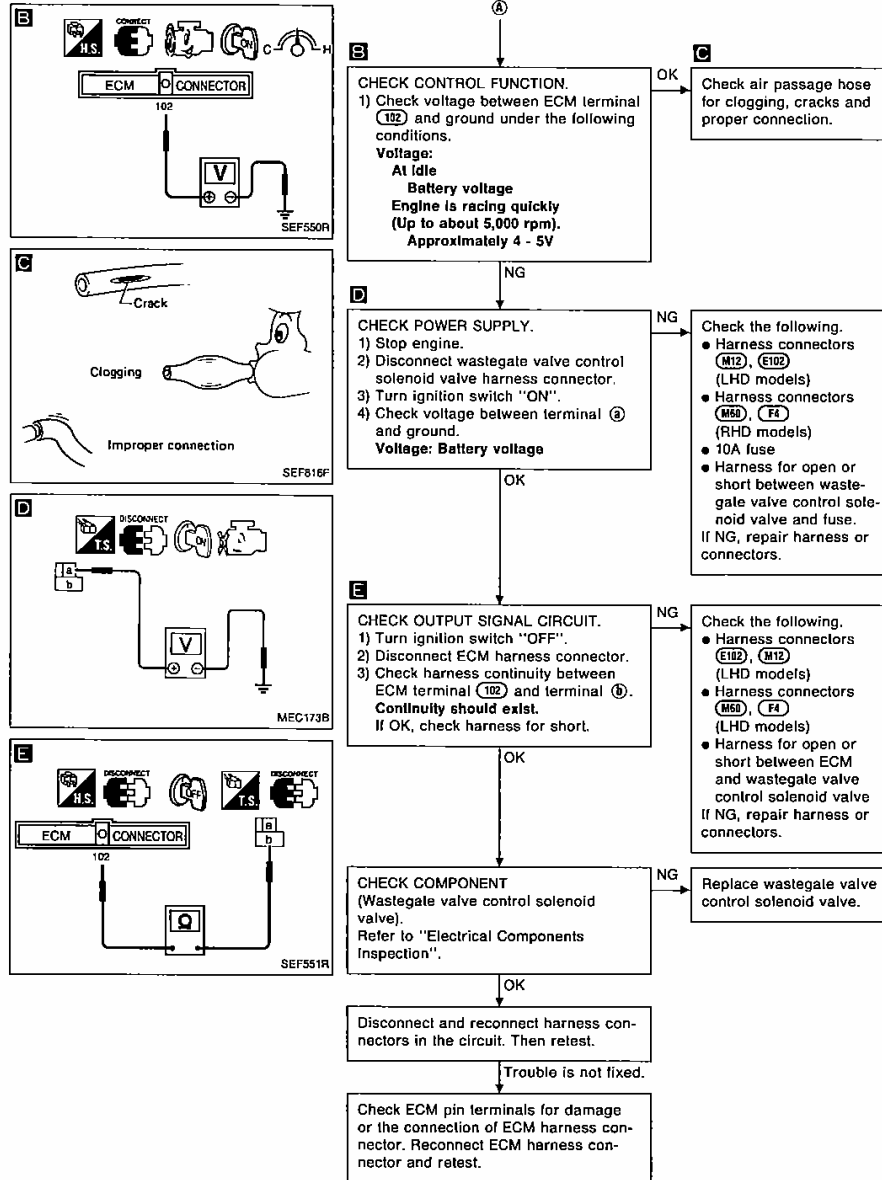

Diagnostic Procedure 38

VALVE TIMING CONTROL (Not self-diagnostic item)

EC-VTC-01

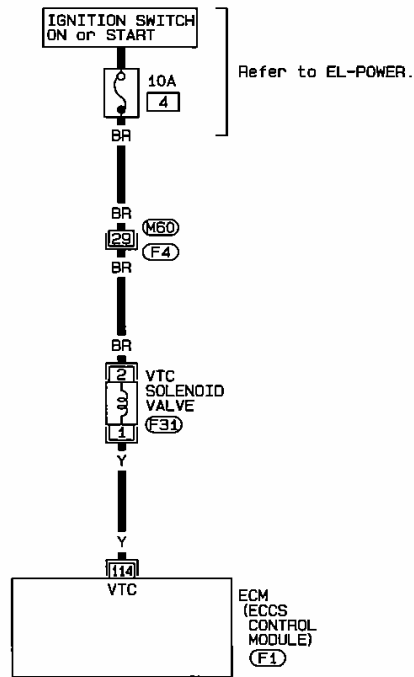

EC



Refer to last page (Foldout page).

M60, F4



F1
L



Diagnostic Procedure 38 (Cont'd)

Harness layout

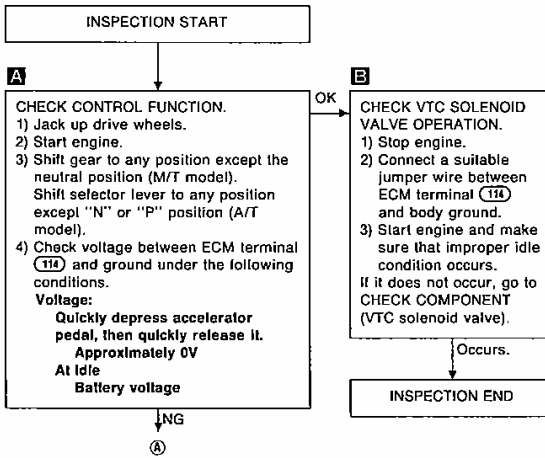
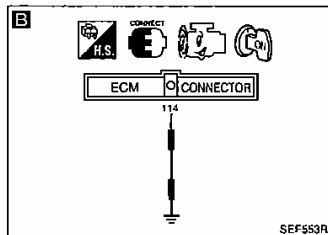
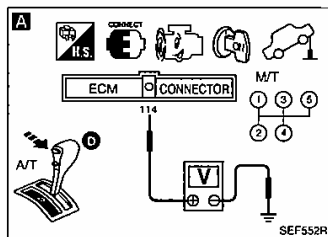
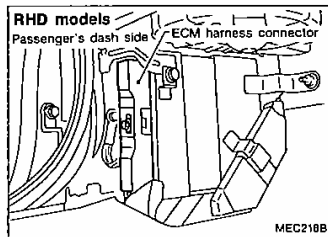
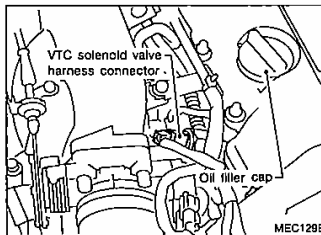
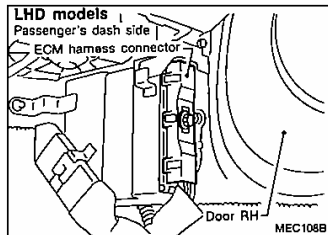

TROUBLE DIAGNOSES

For Europe

Diagnostic Procedure 38 (Cont'd)

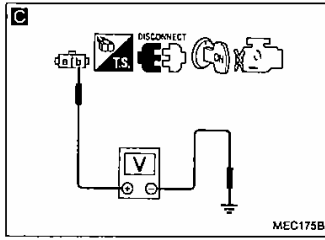

C
CHECK POWER SUPPLY.
 1) Stop engine.
 2) Disconnect VTC solenoid valve harness connector.
 3) Turn ignition switch "ON".
 4) Check voltage between terminal ① and ground.
Voltage: Battery voltage.

NG → Check the following.
 • Harness connectors
 • **M60, F4**
 • 10A fuse
 • Harness for open or short between VTC solenoid valve and fuse
 If NG, repair harness or connectors.

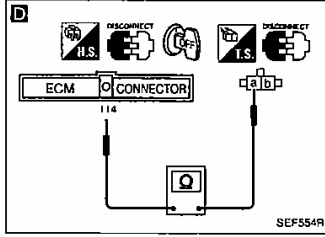

D
CHECK INPUT SIGNAL CIRCUIT.
 1) Turn ignition switch "OFF".
 2) Disconnect ECM harness connector.
 3) Check harness continuity between terminal ③ and ECM terminal 114.
Continuity should exist.
 If OK, check harness for short.

NG → Repair harness or connectors.

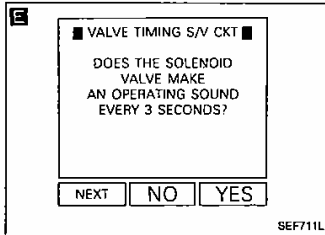

E
CHECK COMPONENT (VTC solenoid valve).
 1) Reconnect ECM harness connector and VTC solenoid valve harness connector.
 2) Turn ignition switch "ON".
 3) Perform "VALVE TIMING S/V CKT" in "FUNCTION TEST" mode with CONSULT.
 OR

NG → Replace VTC solenoid valve.

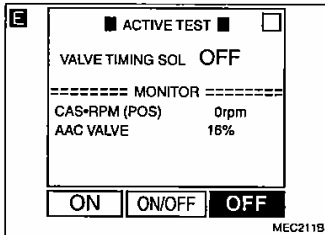

3) Perform "VALVE TIMING SOL" in "ACTIVE TEST" mode with CONSULT.
 4) Turn VTC solenoid valve "ON" and "OFF", and check operating sound.
 OR
 Refer to "Electrical Components Inspection".

OK → Disconnect and reconnect harness connectors in the circuit. Then retest.

Trouble is not fixed.
 Check ECM pin terminals for damage or the connection of ECM harness connector. Reconnect ECM harness connector and retest.

EC

Diagnostic Procedure 39

IACV-AAC VALVE (Not self-diagnostic item)

EC-AAC/V-01

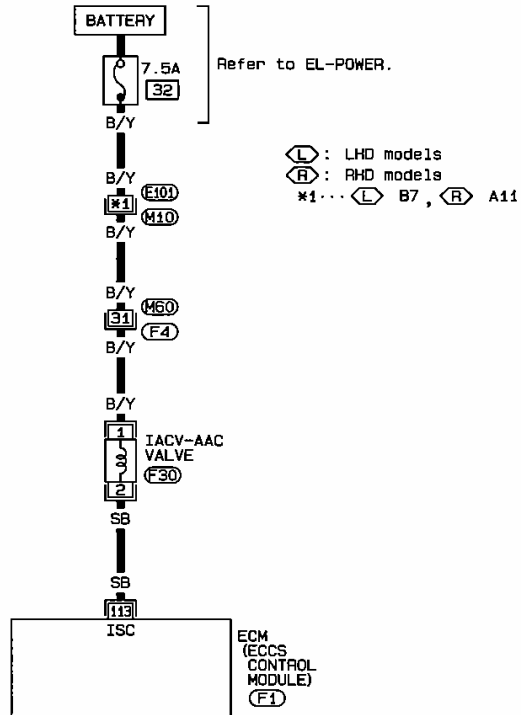

⊗ F30
①② BR

Refer to last page
(Foldout page).

M10, E101
M60, F4

101	102	103	104	105	106	107	108	1	2	3	4	5	6	7	8	9	10	11	12	13	14	15	16	17	18	19	20	21	22	23	24	25	26	27	28	29	30	31	32	33	34	35	36	37	38	39	40	41	42	43	44	45	46	47	48
-----	-----	-----	-----	-----	-----	-----	-----	---	---	---	---	---	---	---	---	---	----	----	----	----	----	----	----	----	----	----	----	----	----	----	----	----	----	----	----	----	----	----	----	----	----	----	----	----	----	----	----	----	----	----	----	----	----	----	----

F1
L



TROUBLE DIAGNOSES

For Europe

Diagnostic Procedure 39 (Cont'd)

Harness layout

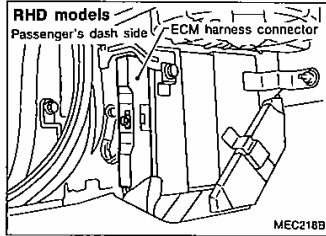
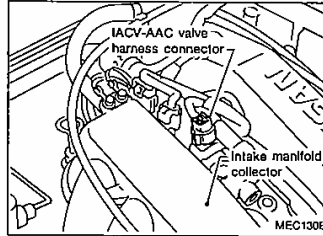
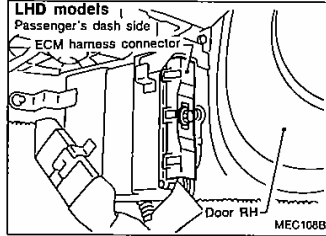

EC

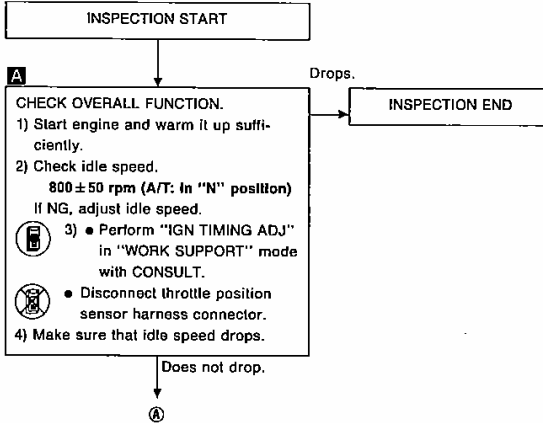
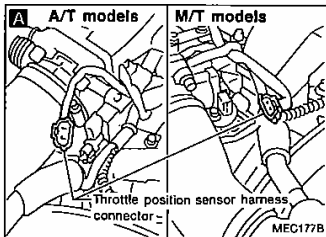
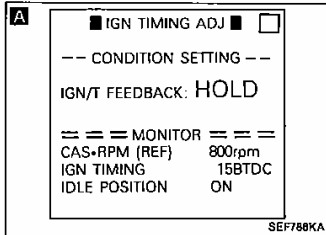

Diagnostic Procedure 39 (Cont'd)

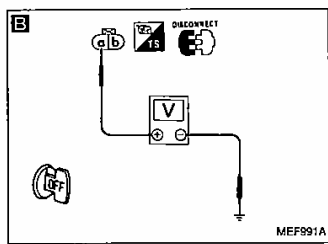

B
CHECK POWER SUPPLY.
 1) Stop engine.
 2) Disconnect IACV-AAC valve harness connector.
 3) Check voltage between terminal ⑪ and ground.
Voltage: Battery voltage

NG → Check the following.
 ● Harness connectors
 ● (E101), (M10)
 ● Harness connectors
 ● (M50), (F4)
 ● 7.5A fuse
 ● Harness for open or short between IACV-AAC valve and fuse
 If NG, repair harness or connectors.

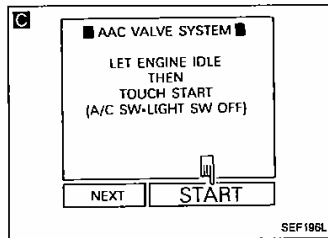

C
CHECK OUTPUT SIGNAL CIRCUIT.
 1) Reconnect IACV-AAC valve harness connector.
 2) Perform "AAC VALVE SYSTEM" or "IACV-AAC/V SYSTEM" in "FUNCTION TEST" mode with CONSULT.
 OR
 2) Perform "AAC VALVE OPENING TEST" or "IACV-AAC/V OPENING" in "ACTIVE TEST" mode with CONSULT.

NG → Repair harness or connectors.

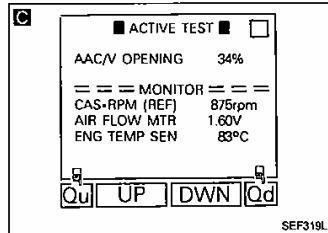

OR
 1) Disconnect ECM harness connector.
 2) Check harness continuity between ECM terminal ⑪③ and terminal ⑪.
Continuity should exist.
 If OK, check harness for short.

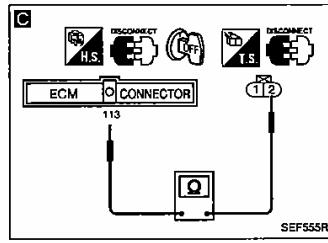

CHECK COMPONENT (IACV-AAC valve).
 Refer to "Electrical Components Inspection".

NG → Replace IACV-AAC valve.

OK → Disconnect and reconnect harness connectors in the circuit. Then retest.

Trouble is not fixed.
 Check ECM pin terminals for damage or the connection of ECM harness connector. Reconnect ECM harness connector and retest.

Diagnostic Procedure 40

IACV-FICD SOLENOID VALVE (Not self-diagnostic item)

LHD MODELS

EC-FICD-01

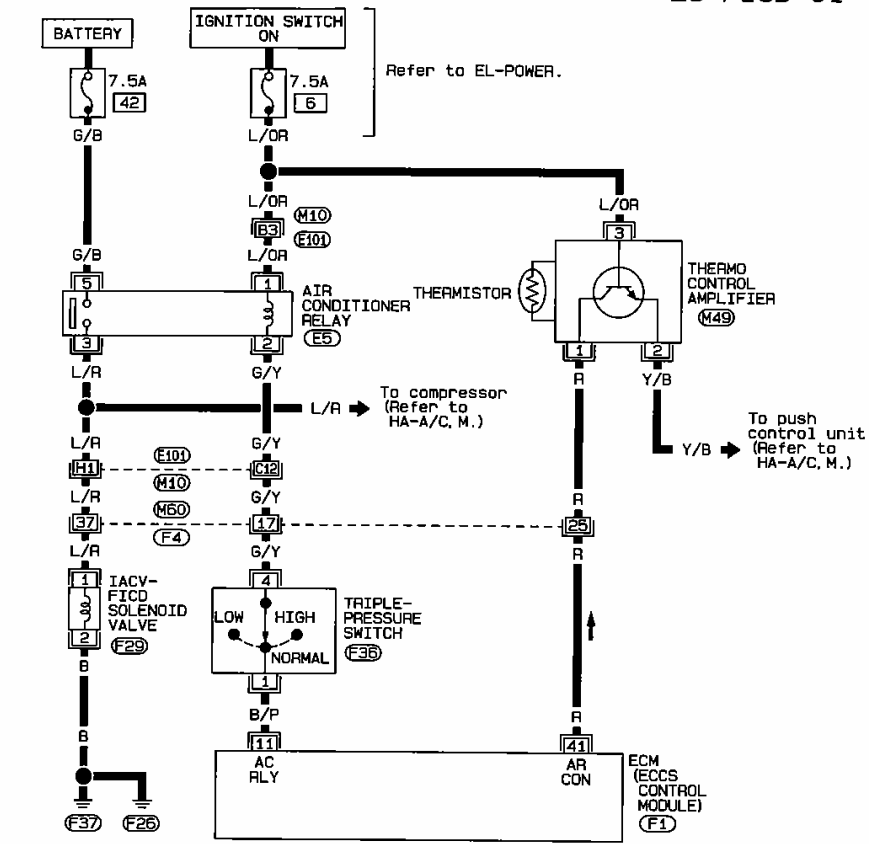

EC

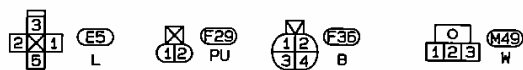

Refer to last page (Foldout page).

M10, E101, M50, F4

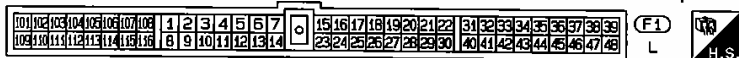

F1 L H.S.

TRUBLE DIAGNOSES

For Europe

Diagnostic Procedure 40 (Cont'd)

RHD MODELS

EC-FICD-02

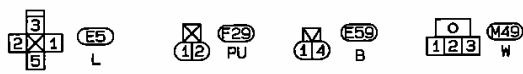
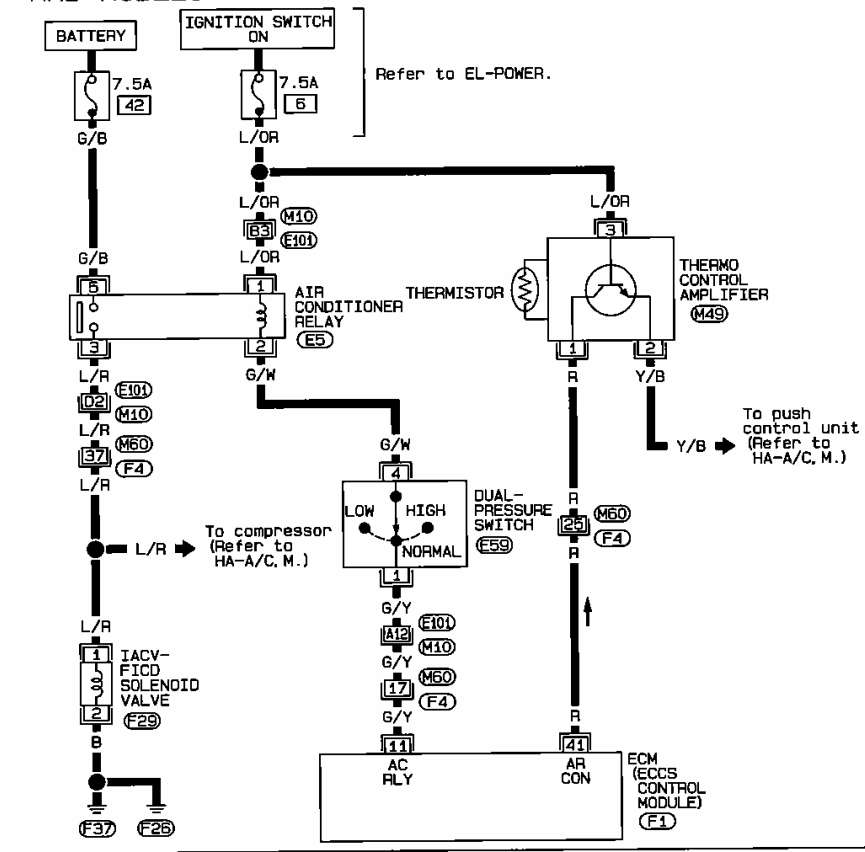

Refer to last page (Foldout page).
 M10, E10
 M60, F4



TROUBLE DIAGNOSES

For Europe

Diagnostic Procedure 40 (Cont'd)

Harness layout

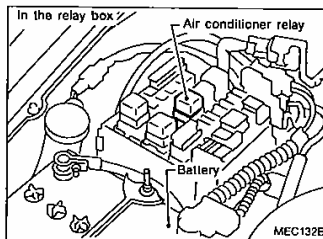
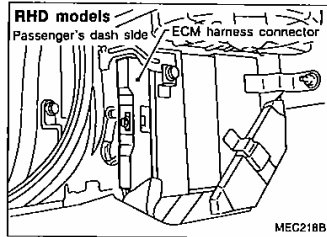
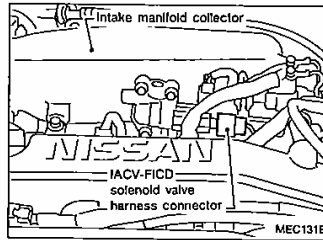
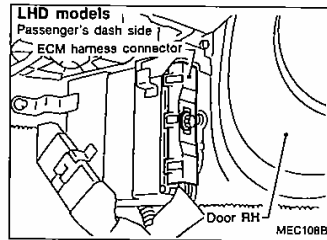

EC

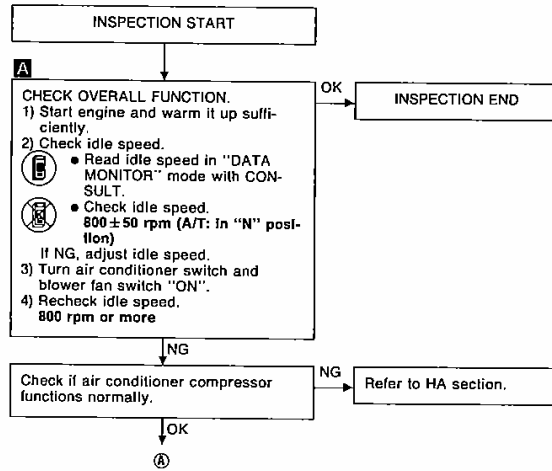
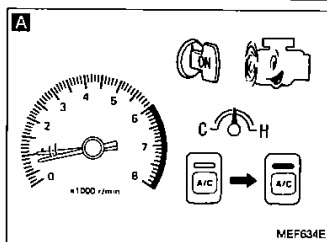
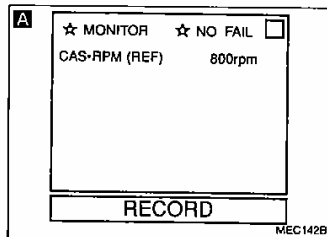

TROUBLE DIAGNOSES

For Europe

Diagnostic Procedure 40 (Cont'd)

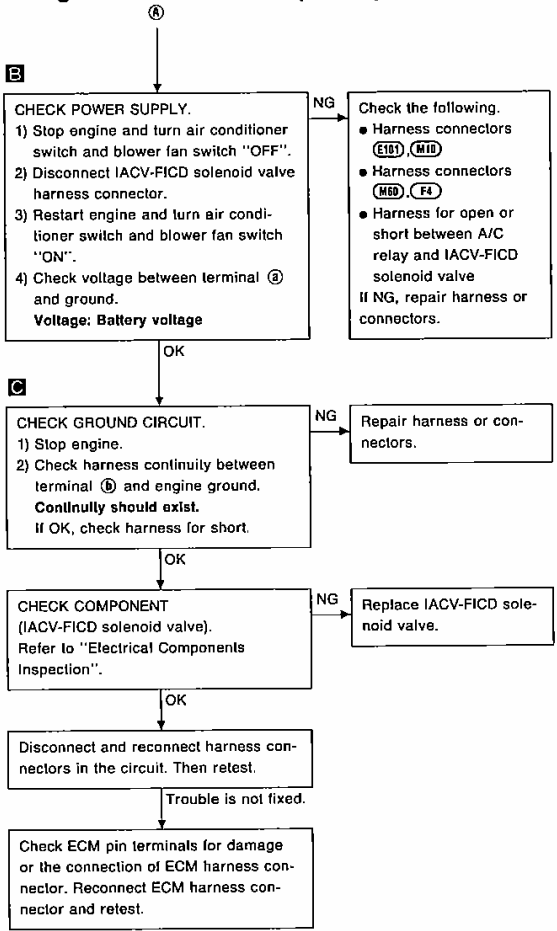
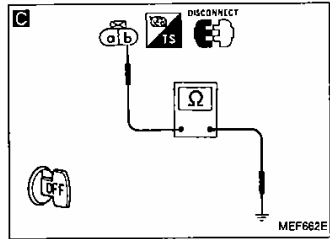
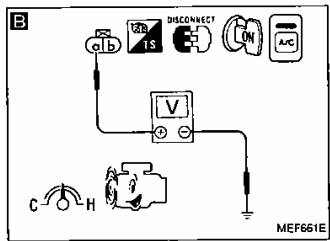

Diagnostic Procedure 41

COOLING FAN CONTROL (Not self-diagnostic item)

EC-COOL/F-01

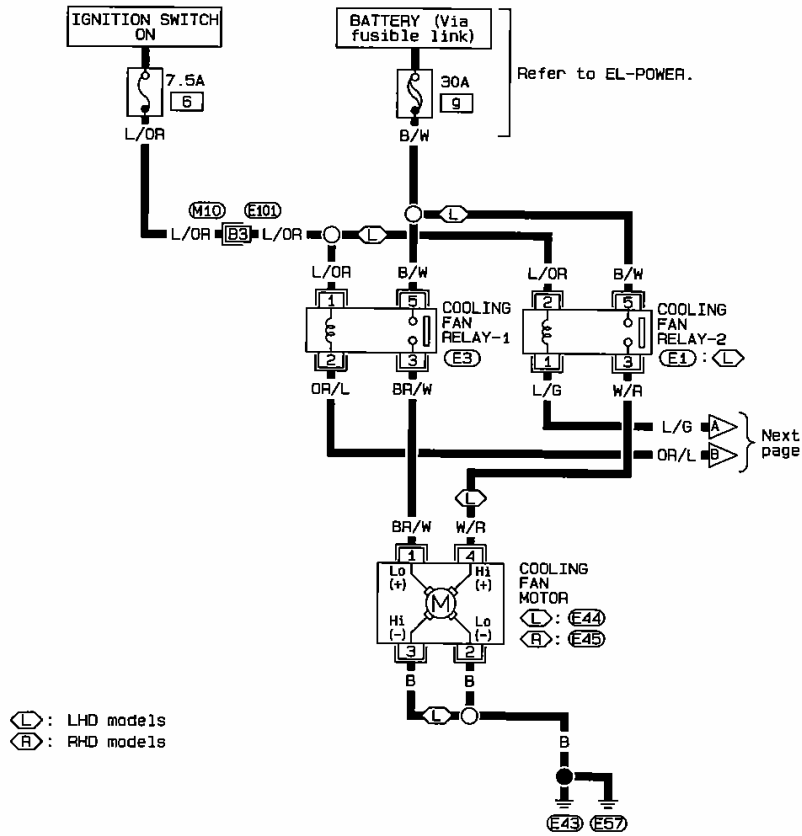

EC

Ⓛ: LHD models
Ⓡ: RHD models

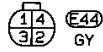
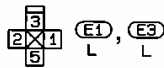

Refer to last page (Foldout page).

M10, E101

Diagnostic Procedure 41 (Cont'd)

EC-COOL/F-02

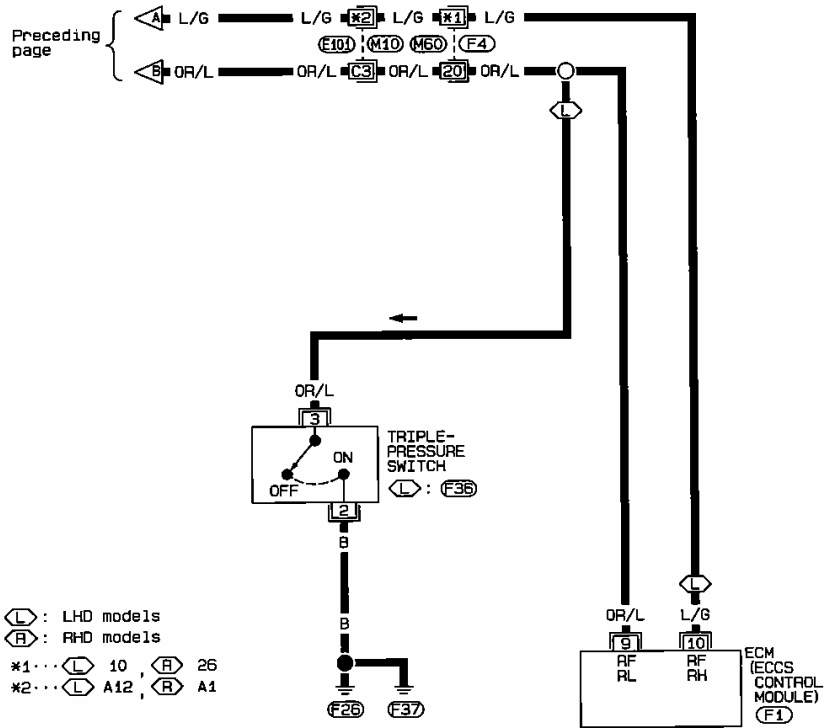

L: LHD models
 R: RHD models
 *1... L 10, R 26
 *2... L A12, R A1

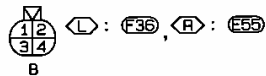

Refer to last page (Foldout page).

M10, E101
 M60, F4

01	02	03	04	05	06	07	08	1	2	3	4	5	6	7	8	9	10	11	12	13	14	15	16	17	18	19	20	21	22	23	24	25	26	27	28	29	30	31	32	33	34	35	36	37	38	39	40	41	42	43	44	45	46	47	48
----	----	----	----	----	----	----	----	---	---	---	---	---	---	---	---	---	----	----	----	----	----	----	----	----	----	----	----	----	----	----	----	----	----	----	----	----	----	----	----	----	----	----	----	----	----	----	----	----	----	----	----	----	----	----	----

F1 L



TROUBLE DIAGNOSES

For Europe

Diagnostic Procedure 41 (Cont'd)

Harness layout

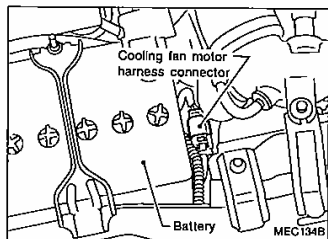
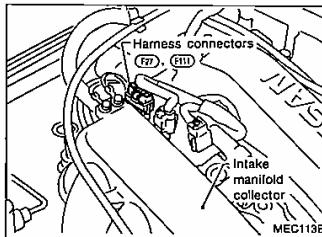
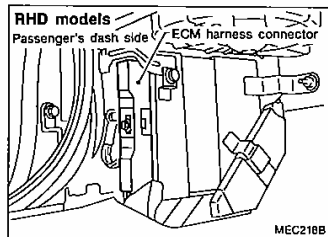
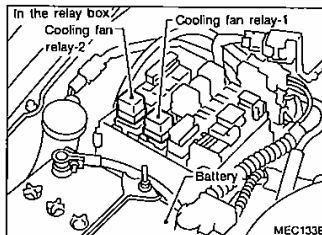
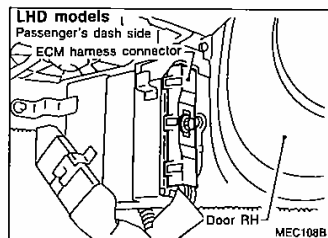

EC

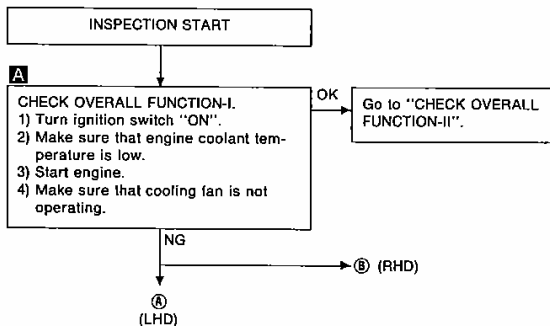
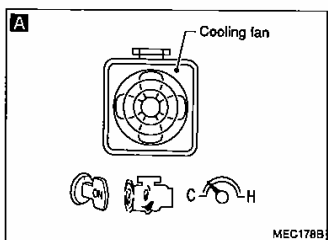

TROUBLE DIAGNOSES

For Europe

Diagnostic Procedure 41 (Cont'd)

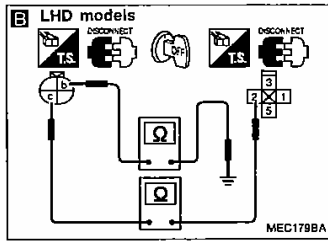

B LHD models

CHECK HARNESS CONTINUITY BETWEEN COOLING FAN RELAY-1 AND GROUND.

- 1) Stop engine.
- 2) Disconnect cooling fan relay-1.
- 3) Disconnect triple-pressure switch harness connector.
- 4) Check harness continuity between terminal ② and terminal ③, terminal ④ and body ground.
Continuity should exist.
If OK, check harness for short.

NG

Check the following.

- Harness connectors (E101), (M10)
- Harness connectors (MSD), (F4)
- Harness for open or short between cooling fan relay-1 and triple-pressure switch
- Harness for open or short between triple-pressure switch and body ground.

If NG, repair harness or connectors.

OK

CHECK COMPONENT (Triple-pressure switch).
Refer to "HA section".

NG

Replace triple-pressure switch.

OK

Go to "CHECK OUTPUT SIGNAL CIRCUIT" in **PROCEDURE A**.

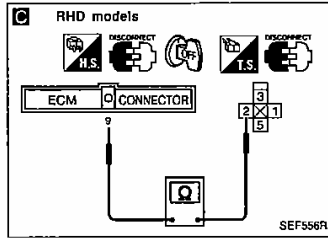

C RHD models

CHECK HARNESS CONTINUITY BETWEEN COOLING FAN RELAY-1 AND ECM.

- 1) Stop engine.
- 2) Disconnect cooling fan relay-1.
- 3) Disconnect ECM harness connector.
- 4) Check harness continuity between terminal ② and ECM terminal ③.
Continuity should exist.
If OK, check harness for short.

NG

Check the following.

- Harness connectors (E101), (M10)
- Harness connectors (MSD), (F4)
- Harness for open or short between cooling fan relay-1 and ECM

If NG, repair harness or connectors.

OK

Go to "CHECK OUTPUT SIGNAL CIRCUIT" in **PROCEDURE A**.

Diagnostic Procedure 41 (Cont'd)

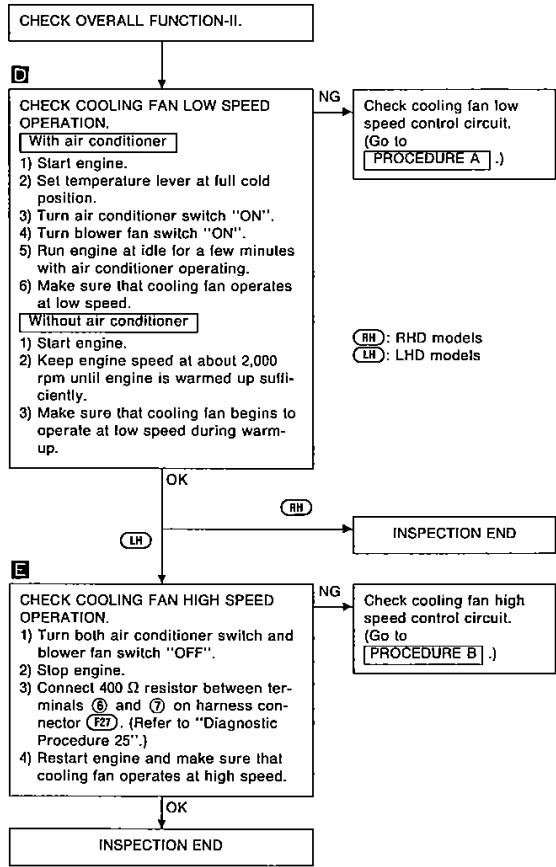
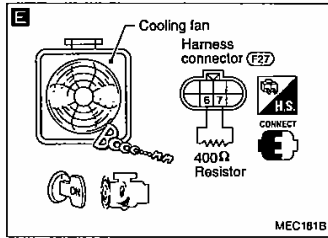
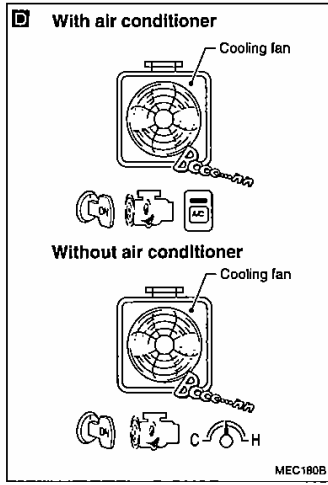

EC

Diagnostic Procedure 41 (Cont'd)

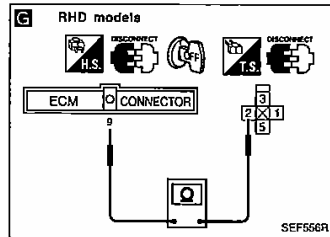
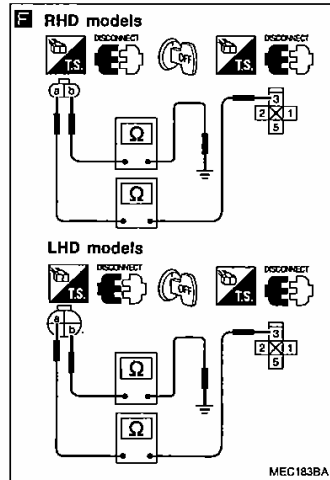
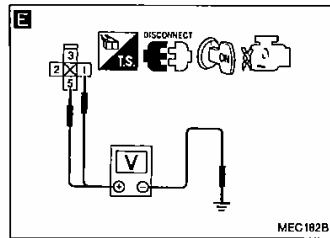

TROUBLE DIAGNOSES

For Europe

Diagnostic Procedure 41 (Cont'd)

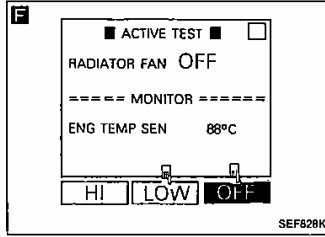
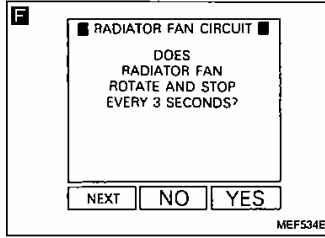

F

CHECK COMPONENT
(Cooling fan motor).

- 1) Reconnect cooling fan relay-1, cooling fan motor harness connector and ECM harness connector.
- 2) Turn ignition switch "ON".
- 3) Perform "RADIATOR FAN CIRCUIT" or "COOLING FAN CIRCUIT" in "FUNCTION TEST" mode with CONSULT.

OR

- 3) Perform "RADIATOR FAN TEST" or "COOLING FAN" in "ACTIVE TEST" mode with CONSULT.

OR

Refer to "Electrical Components Inspection".

NG → Replace cooling fan motor.

OK → Disconnect and reconnect harness connectors in the circuit. Then retest.

↓ Trouble is not fixed.

Check ECM pin terminals for damage or the connection of ECM harness connector. Reconnect ECM harness connector and retest.

EC

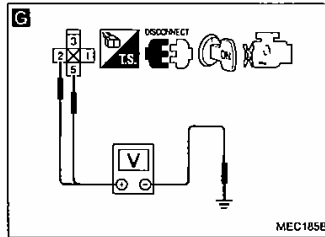

PROCEDURE B

INSPECTION START

C

CHECK POWER SUPPLY.

- 1) Stop engine.
- 2) Disconnect cooling fan relay-2.
- 3) Turn ignition switch "ON".
- 4) Check voltage between terminals ②, ⑤ and ground.

Voltage: Battery voltage

NG → Check the following.

- Harness for open or short between cooling fan relay-2 and harness connector (E10)
- Harness for open or short between cooling fan relay-2 and fusible link

If NG, repair harness or connectors.

OK →

⑥

TROUBLE DIAGNOSES

For Europe

Diagnostic Procedure 41 (Cont'd)

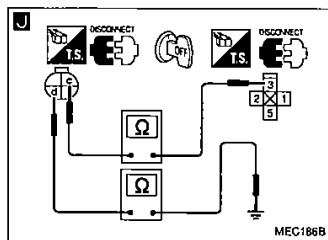

J
CHECK GROUND CIRCUIT.
 1) Turn ignition switch "OFF".
 2) Disconnect cooling fan motor harness connector.
 3) Check harness continuity between terminal ③ and terminal ⑥, terminal ④ and body ground.
Continuity should exist.
 If OK, check harness for short.

NG → Repair harness or connectors.

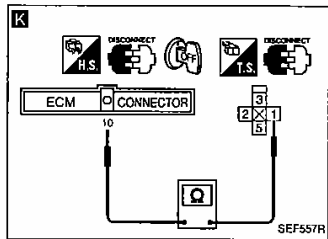

K
CHECK OUTPUT SIGNAL CIRCUIT.
 1) Disconnect ECM harness connector.
 2) Check harness continuity between ECM terminal ⑩ and terminal ①.
Continuity should exist.
 If OK, check harness for short.

NG → Check the following.
 • Harness connectors (E10), (M10)
 • Harness connectors (MSB), (F4)
 • Harness for open or short between ECM and cooling fan relay-2
 If NG, repair harness or connectors.

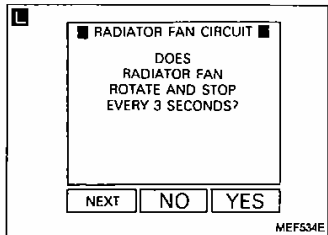

L
CHECK COMPONENT (Cooling fan relay-2).
 Refer to "Electrical Components Inspection".

NG → Replace cooling fan relay.

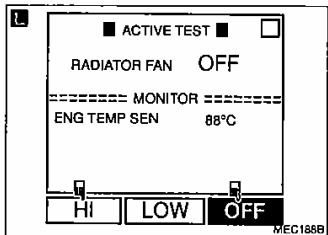

M
CHECK COMPONENT (Cooling fan motor).
 1) Reconnect cooling fan relay-2, cooling fan motor harness connector and ECM harness connector.
 2) Disconnect 400 Ω resistor from harness connector (F27).
 3) Turn ignition switch "ON".
 4) Perform "RADIATOR FAN CIRCUIT" or "COOLING FAN CIRCUIT" in "FUNCTION TEST" mode with CONSULT.
 — OR —
 4) Perform "RADIATOR FAN TEST" or "COOLING FAN" in "ACTIVE TEST" mode with CONSULT.
 — OR —
 Refer to "Electrical Components Inspection".

NG → Replace cooling fan motor.

OK → Disconnect and reconnect harness connectors in the circuit. Then retest.

→ Trouble is not fixed.

Check ECM pin terminals for damage or the connection of ECM harness connector. Reconnect ECM harness connector and retest.

Diagnostic Procedure 42

POWER STEERING OIL PRESSURE SWITCH (Not self-diagnostic item)

EC-PST/SW-01

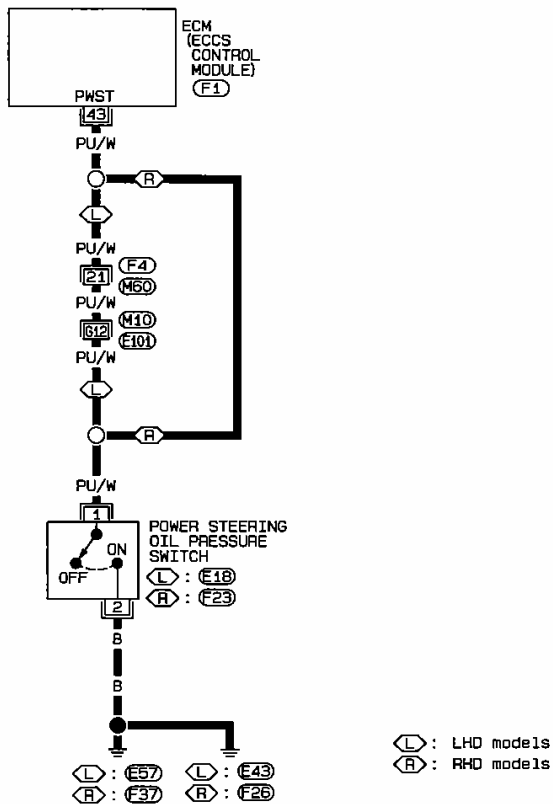

EC

12 GY L : E18, R : F23

Refer to last page (Foldout page).

M10, E101
M60, F4

101	102	103	104	105	106	107	108	1	2	3	4	5	6	7	10	15	16	17	18	19	20	21	22	31	32	33	34	35	36	37	38	39
109	110	111	112	113	114	115	116	8	9	10	11	12	13	14	10	23	24	25	26	27	28	29	30	40	41	42	43	44	45	46	47	48

F1 L

H.S.

TROUBLE DIAGNOSES

For Europe

Diagnostic Procedure 42 (Cont'd)

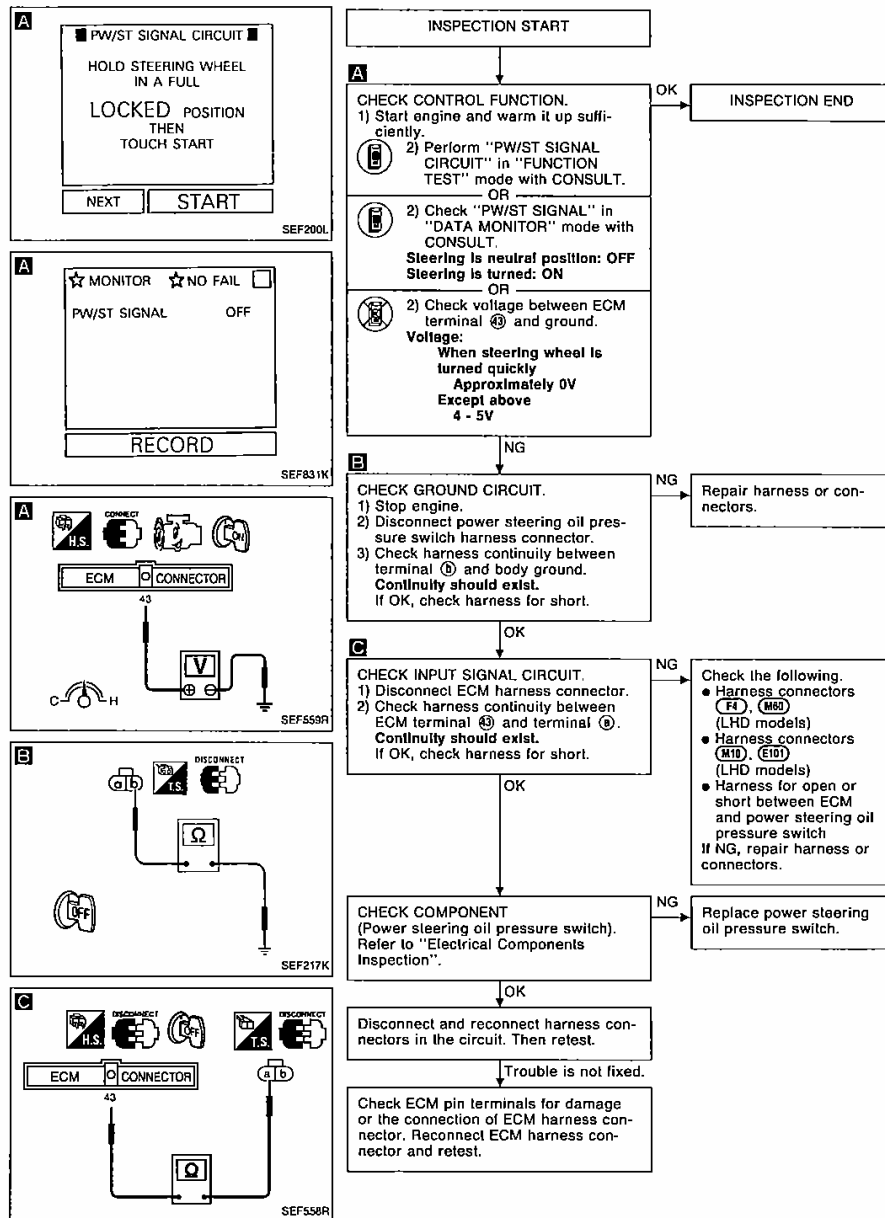

Diagnostic Procedure 43

NEUTRAL POSITION SWITCH & A/T CONTROL UNIT (PARK/NEUTRAL POSITION SIGNAL)
(Not self-diagnostic item)

EC-PNP/SW-01

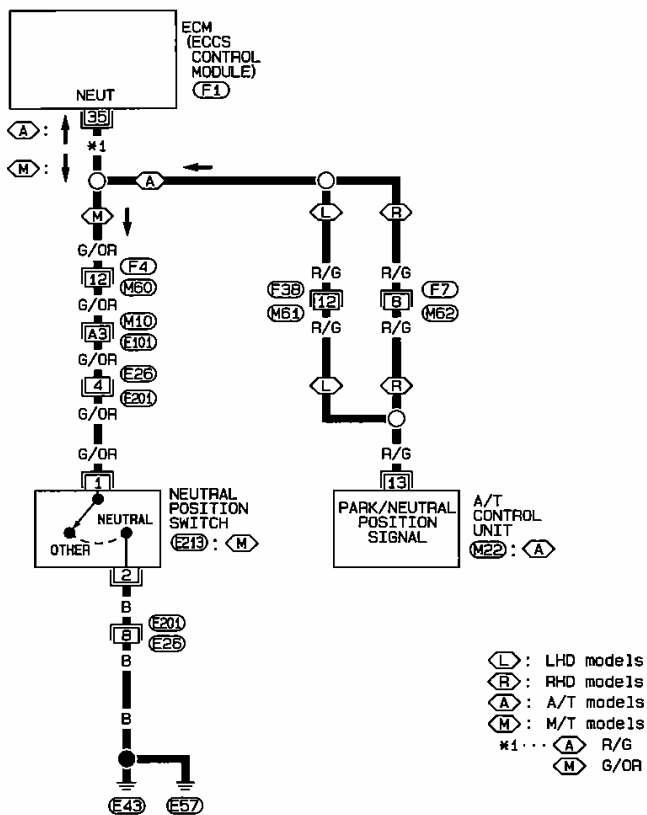

EC

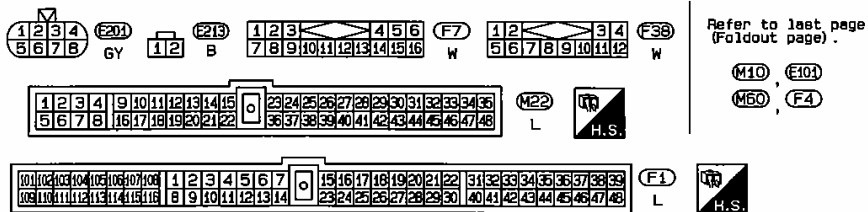

TROUBLE DIAGNOSES

For Europe

Diagnostic Procedure 43 (Cont'd)

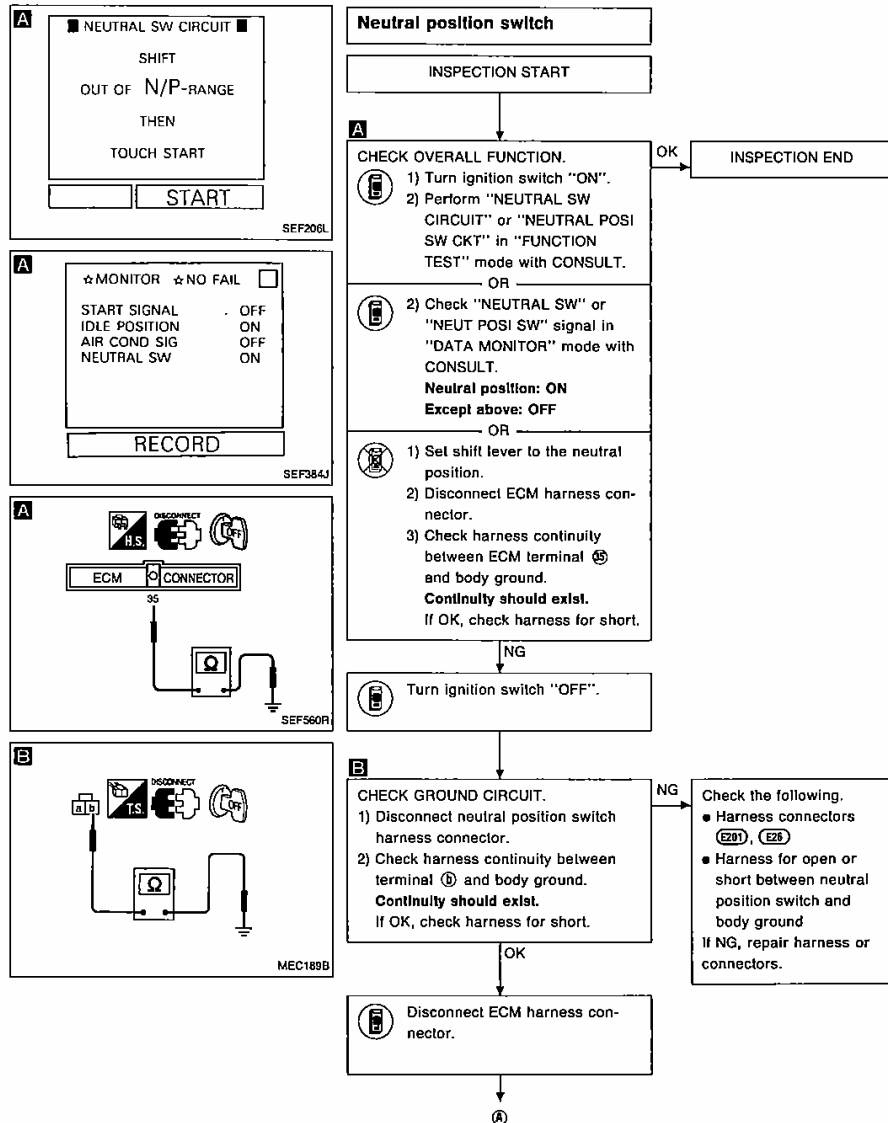

TROUBLE DIAGNOSES

For Europe

Diagnostic Procedure 43 (Cont'd)

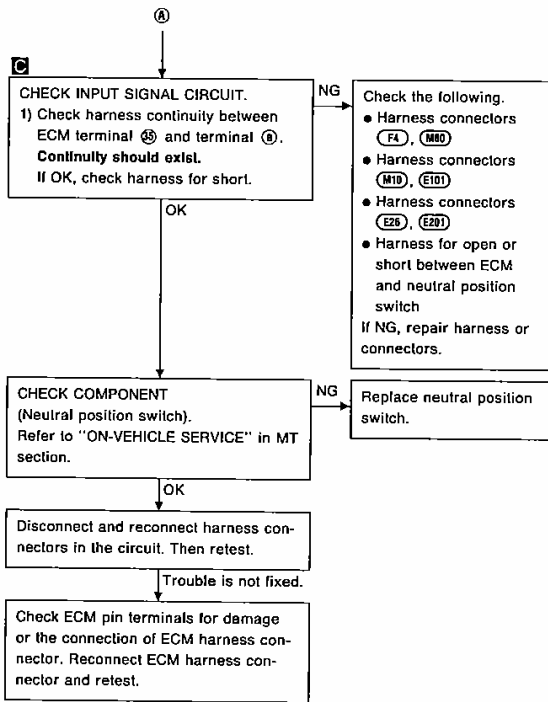
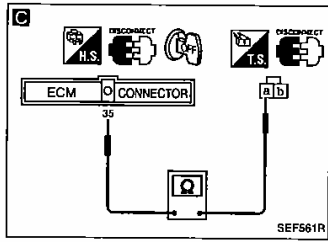

EC

TROUBLE DIAGNOSES

For Europe

Diagnostic Procedure 43 (Cont'd)

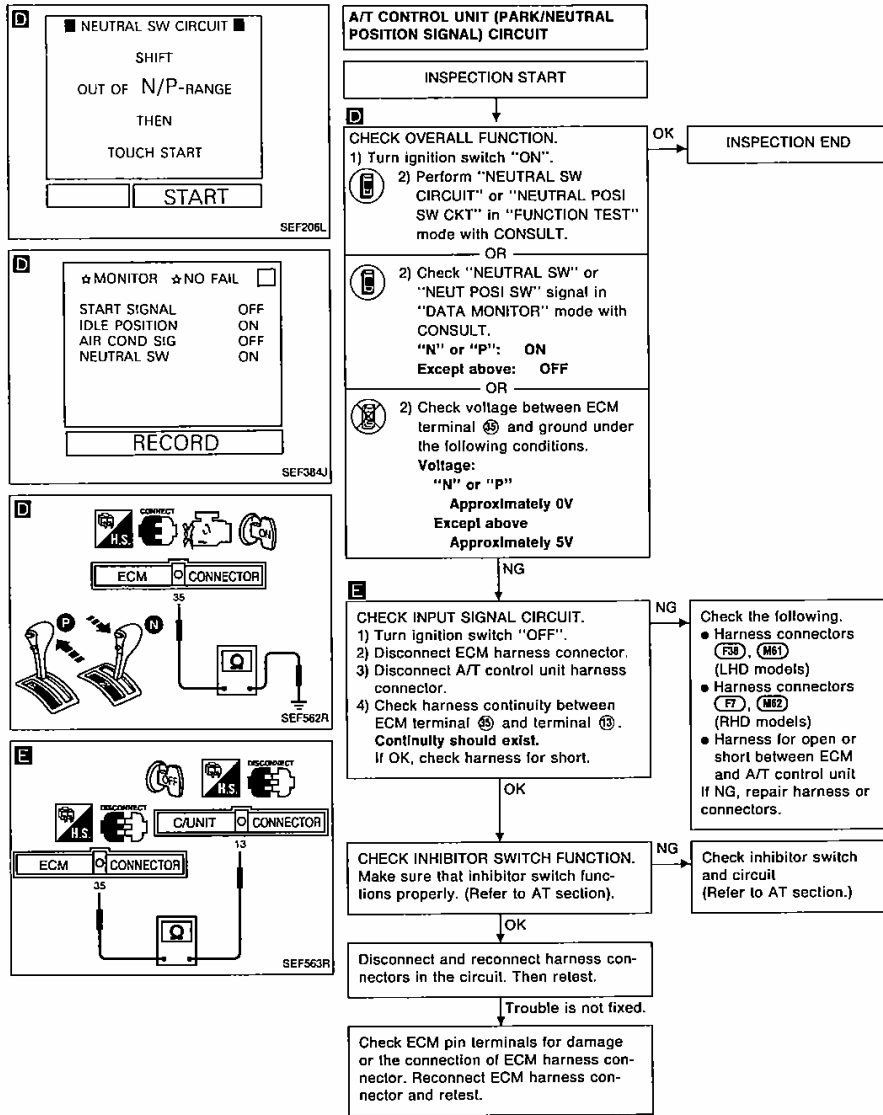

Diagnostic Procedure 44

REAR WINDOW DEFOGGER SWITCH (Not self-diagnostic item)

EC-DEF/S-01

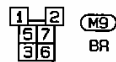
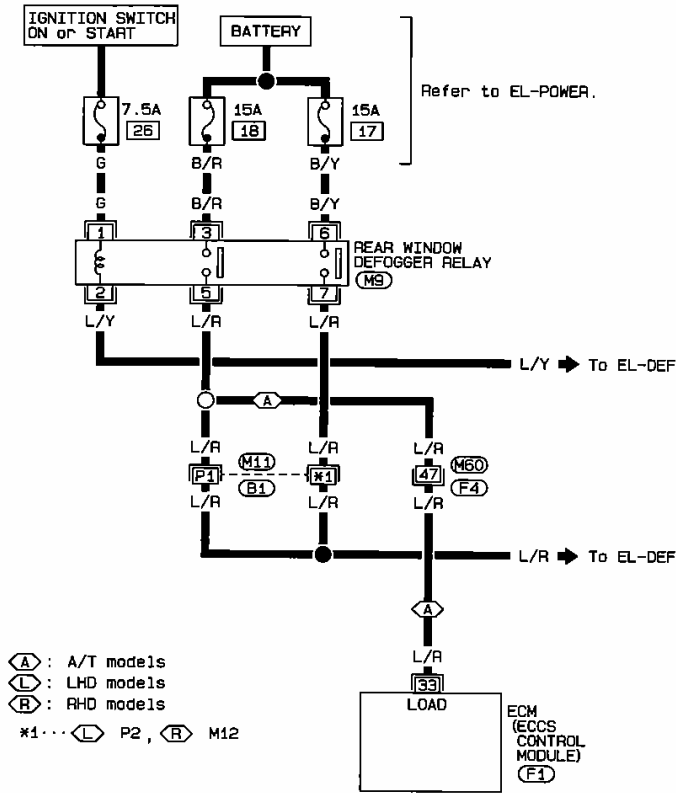

Refer to last page (Foldout page).

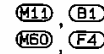

10	11	12	13	14	15	16	17	18	19	20	21	22	23	24	25	26	27	28	29	30	31	32	33	34	35	36	37	38	39
40	41	42	43	44	45	46	47	48																					

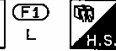

TROUBLE DIAGNOSES

For Europe

Diagnostic Procedure 44 (Cont'd)

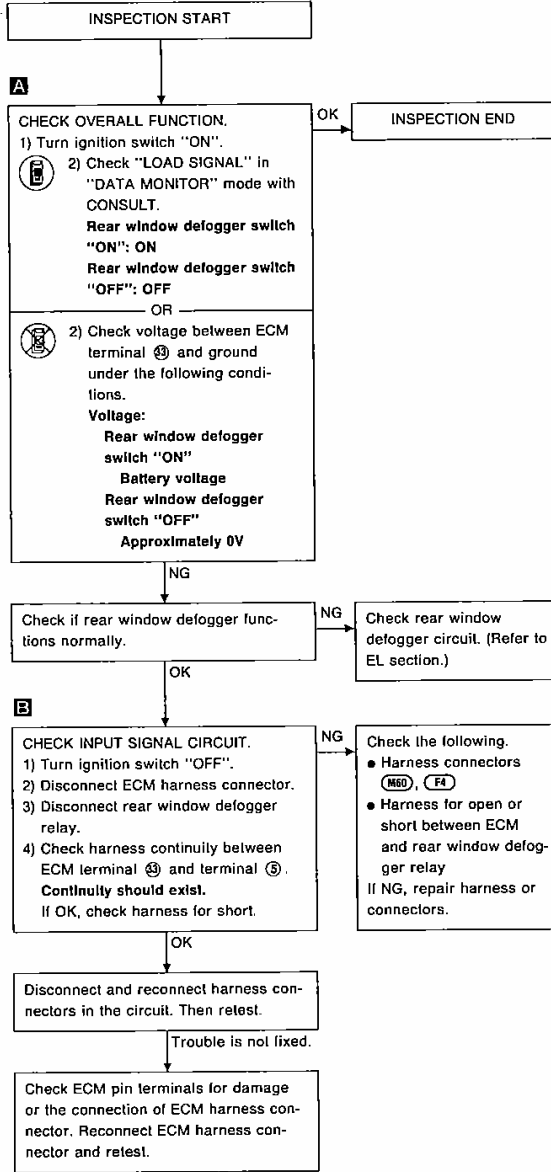
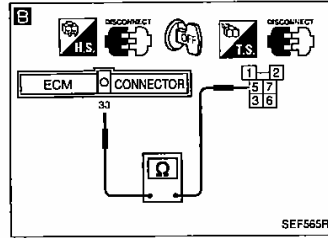
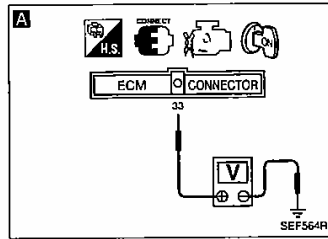
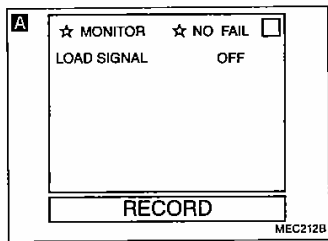

Diagnostic Procedure 45

MALFUNCTION INDICATOR LAMP & DATA LINK CONNECTOR FOR CONSULT (Not self-diagnostic item)

EC-MIL-01

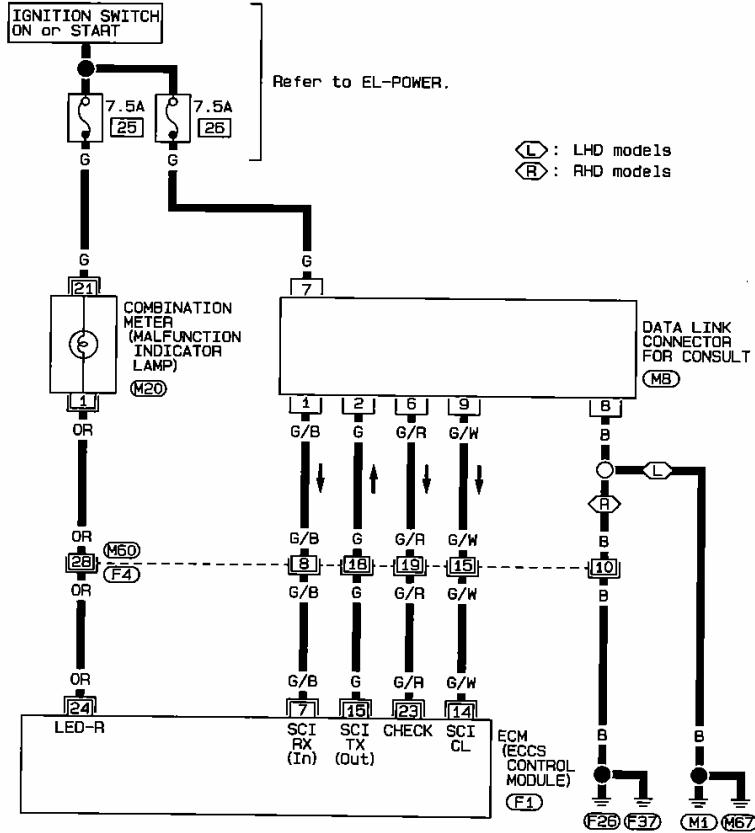

L : LHD models
R : RHD models

EC

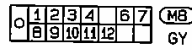
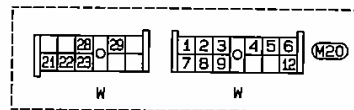

Refer to last page (Foldout page).

M20, F4



F1 L



HEC173

Diagnostic Procedure 22

MAIN POWER SUPPLY AND GROUND CIRCUIT (Not self-diagnostic item)

EC-MAIN-01

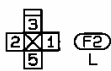
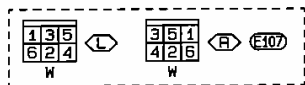
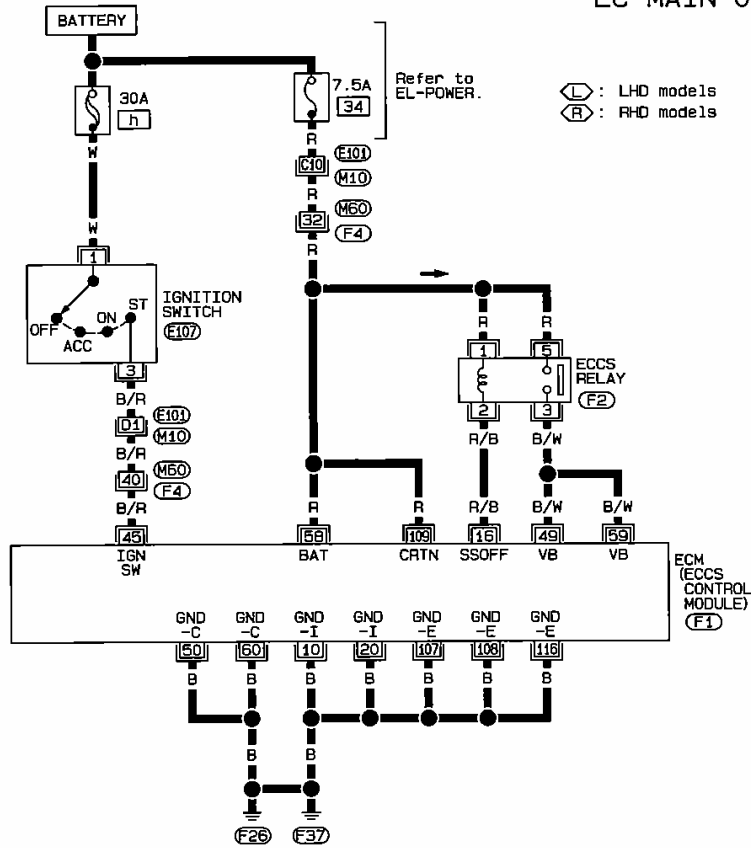

Refer to last page (Foldout page).

M10, E101
M60, F4

101	102	103	104	105	106	107	108	109	110	1	2	3	4	5	6	7	8	9	10	0	21	22	23	24	25	26	27	28	29	30	41	42	43	44	45	46	47	48	49	50
109	110	111	112	113	114	115	116	117	118	119	120	31	32	33	34	35	36	37	38	39	40	51	52	53	54	55	56	57	58	59	60									

F1 L H.S.

TROUBLE DIAGNOSES

Except for Europe

Diagnostic Procedure 22 (Cont'd)

Harness layout

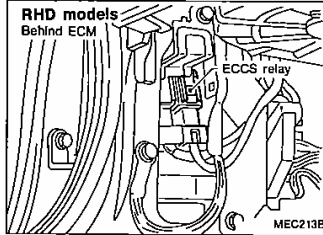
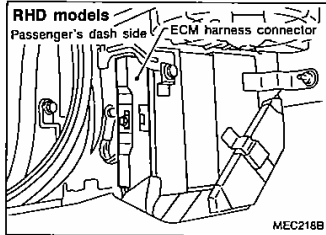
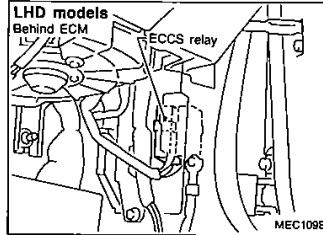
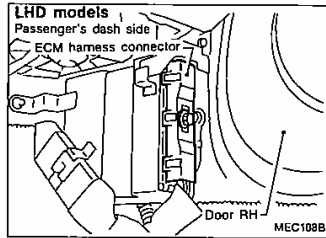

EC

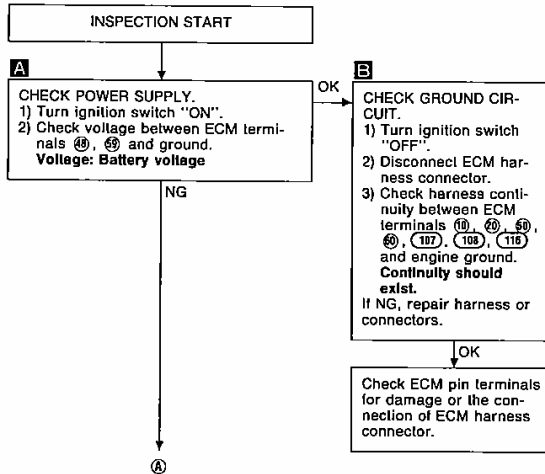
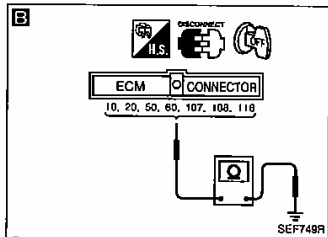
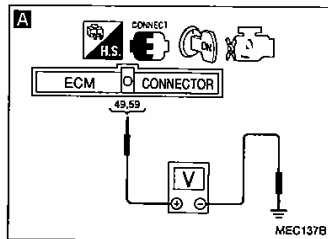

TROUBLE DIAGNOSES

Except for Europe

Diagnostic Procedure 22 (Cont'd)

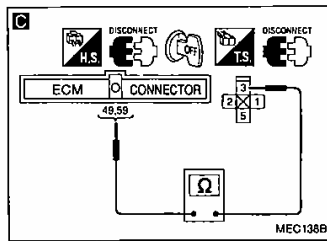

C

CHECK HARNESS CONTINUITY BETWEEN ECCS RELAY AND ECM.

- 1) Turn ignition switch "OFF".
- 2) Disconnect ECM harness connector.
- 3) Disconnect ECCS relay.
- 4) Check harness continuity between ECM terminals ④, ⑤ and terminal ③.

Continuity should exist.
If OK, check harness for short.

NG → Repair harness or connectors.

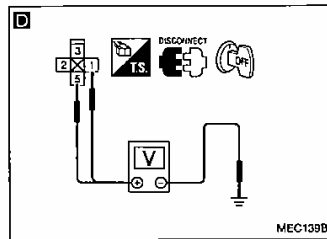

D

CHECK VOLTAGE BETWEEN ECCS RELAY AND GROUND.

- 1) Check voltage between terminals ①, ⑤ and ground.

Voltage: Battery voltage

NG → Check the following.
 • 7.5A fuse
 • Harness connectors (E1D1), (M1D)
 • Harness connectors (M5D), (F4)
 • Harness for open or short between ECCS relay and battery
 If NG, repair harness or connectors.

OK →

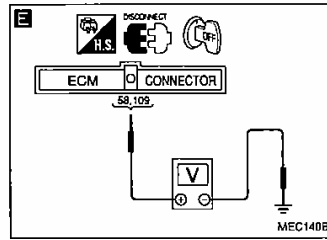

E

CHECK VOLTAGE BETWEEN ECM AND GROUND.

- 1) Check voltage between ECM terminals ⑥, ⑩ and ground.

Voltage: Battery voltage

NG → Check the following.
 • Harness for open or short between ECM and harness connector (F4)
 If NG, repair harness or connectors.

OK →

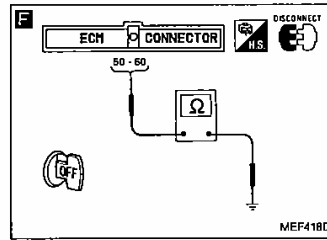

F

CHECK GROUND CIRCUIT.

- 1) Check harness continuity between ECM terminals ⑩, ⑥ and engine ground.

Continuity should exist.
If OK, check harness for short.

NG → Repair harness or connectors.

OK →

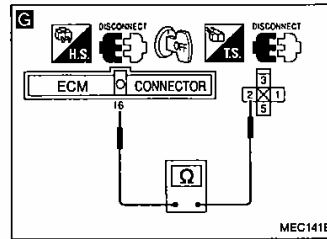

G

CHECK OUTPUT SIGNAL CIRCUIT.

- 1) Check harness continuity between ECM terminal ⑬ and terminal ②.

Continuity should exist.
If OK, check harness for short.

NG → Repair harness or connectors.

OK → ⑧

TROUBLE DIAGNOSES

Except for Europe

Diagnostic Procedure 22 (Cont'd)

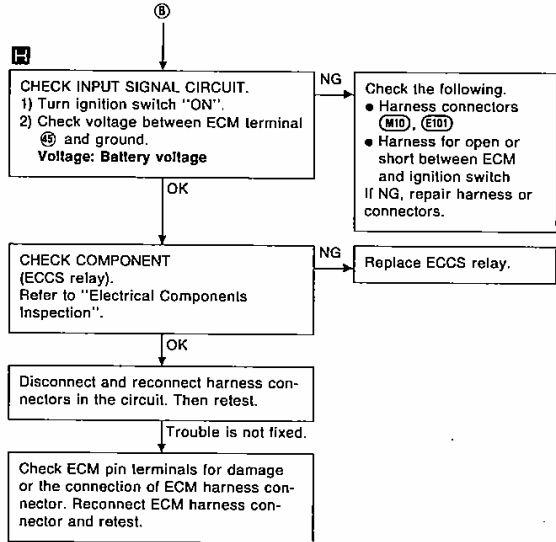
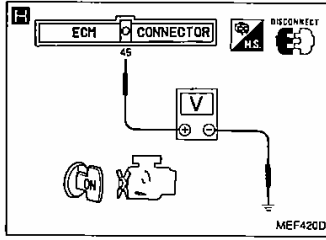

EC

TROUBLE DIAGNOSES

Except for Europe

Diagnostic Procedure 23 (Cont'd)

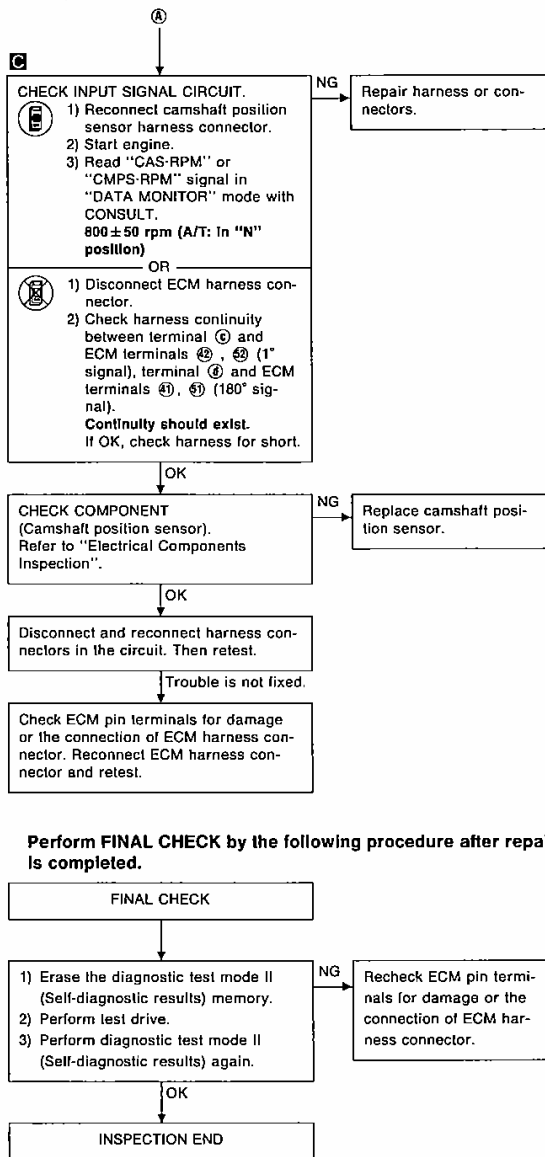
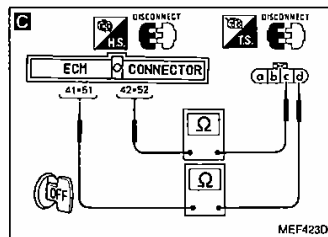
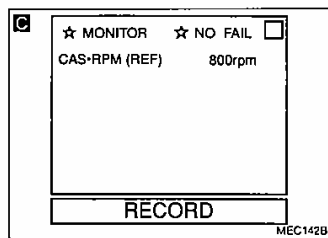

Diagnostic Procedure 24

MASS AIR FLOW SENSOR (Diagnostic trouble code No. 12)

EC-MAFS-01

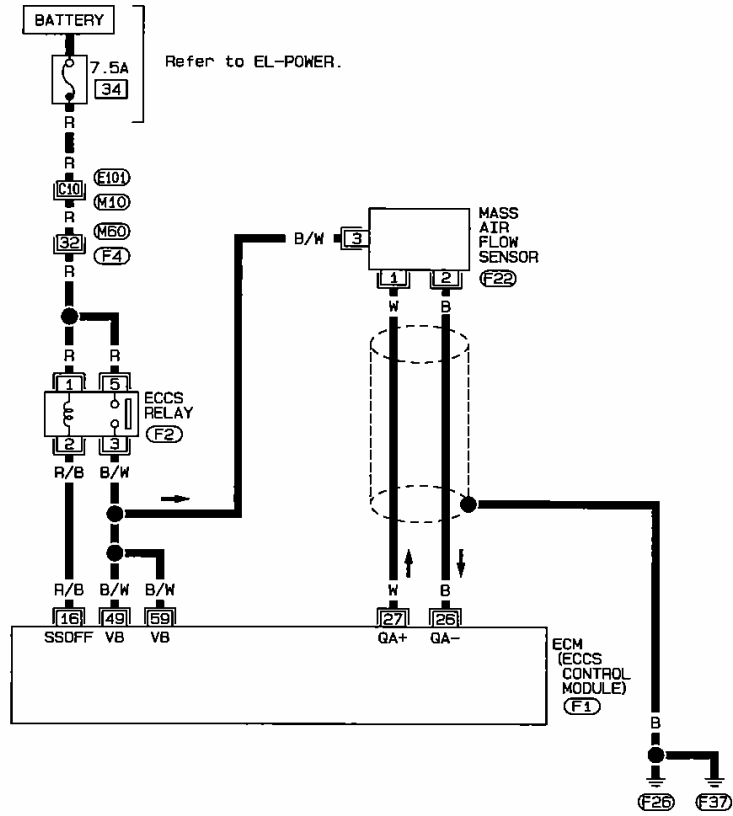

EC

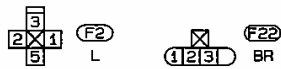

Refer to last page (Foldout page).

- (M10), (E101)
- (M60), (F4)

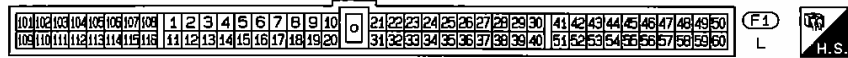

TROUBLE DIAGNOSES

Except for Europe

Diagnostic Procedure 24 (Cont'd)

Harness layout

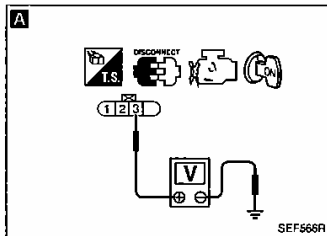
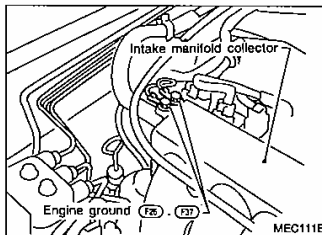
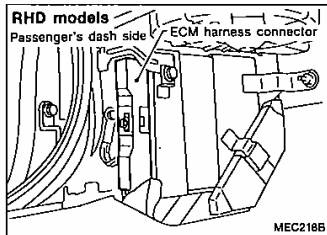
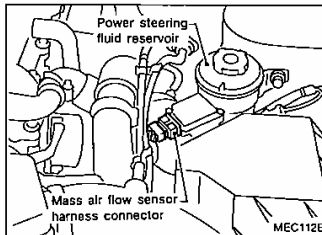
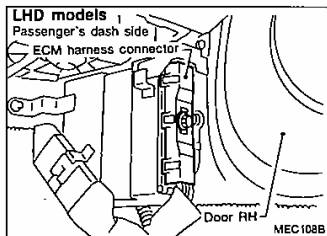

INSPECTION START

A
CHECK POWER SUPPLY.
1) Disconnect mass air flow sensor harness connector.
2) Turn ignition switch "ON".
3) Check voltage between terminal ③ and ground.
Voltage: Battery voltage

NG → Check the following.
• Harness for open or short between mass air flow sensor and ECCS relay
If NG, repair harness or connectors.

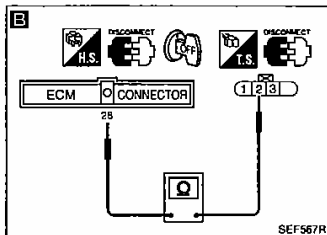

B
CHECK GROUND CIRCUIT.
1) Turn ignition switch "OFF".
2) Disconnect ECM harness connector.
3) Loosen and retighten ground screws.
4) Check harness continuity between terminal ② and ECM terminal ②⑥.
Continuity should exist.
If OK, check harness for short.

NG → Repair harness or connectors.

OK
A

TROUBLE DIAGNOSES

Except for Europe

Diagnostic Procedure 24 (Cont'd)

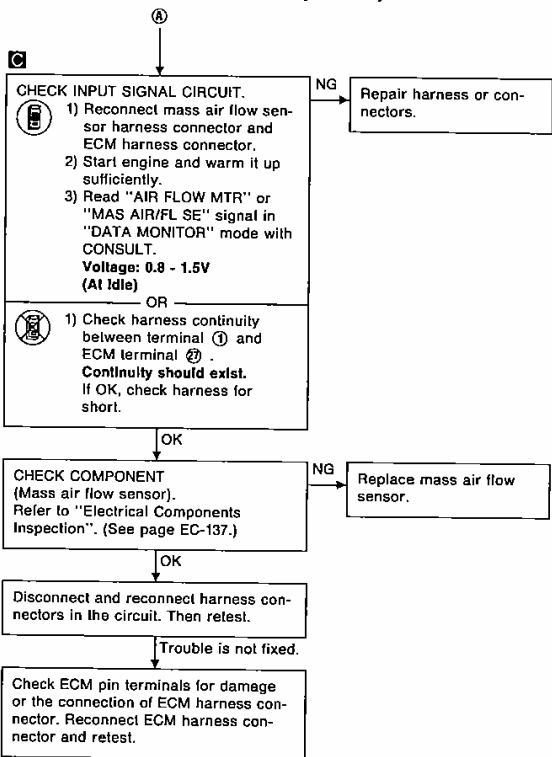
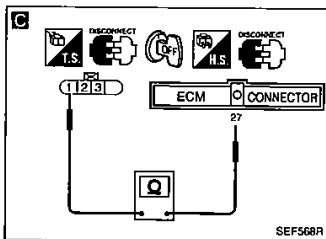
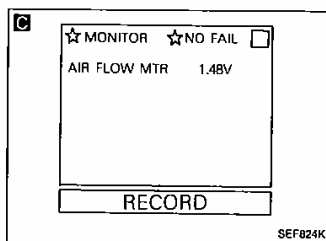

EC

Perform FINAL CHECK by the following procedure after repair is completed.

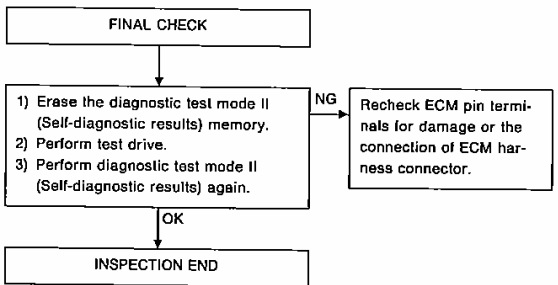

Diagnostic Procedure 25

ENGINE COOLANT TEMPERATURE SENSOR (Diagnostic trouble code No. 13)

EC-ECTS-01

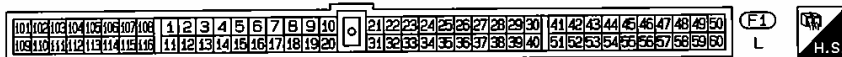
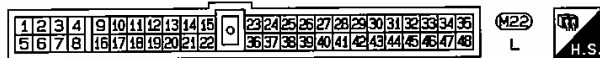
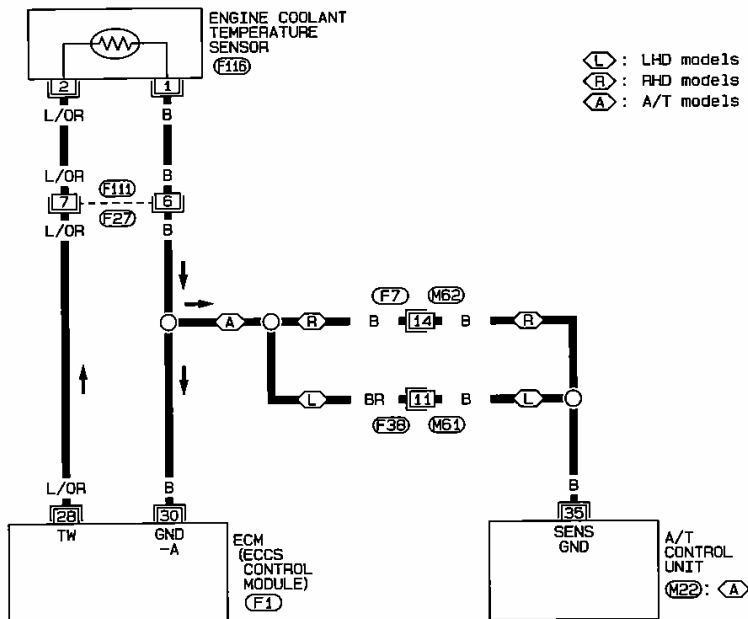

TROUBLE DIAGNOSES

Except for Europe

Diagnostic Procedure 25 (Cont'd)

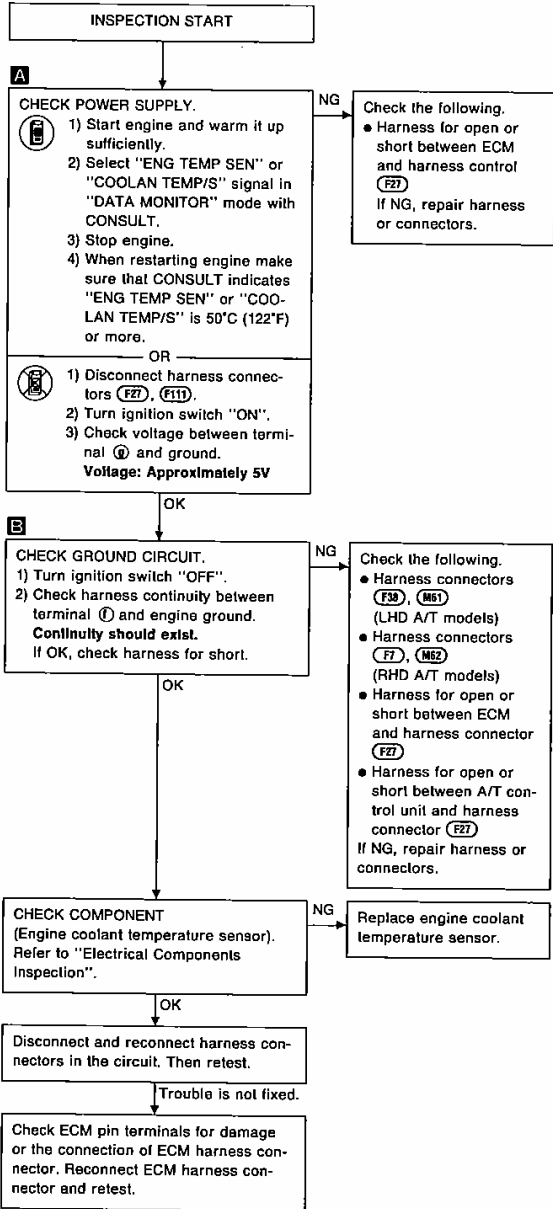
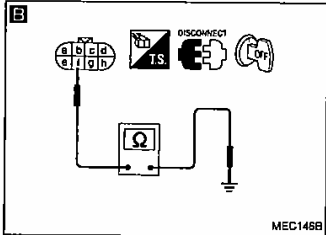
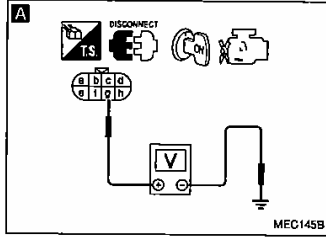
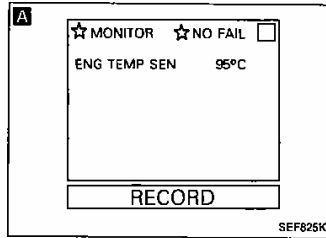

EC

TROUBLE DIAGNOSES

Except for Europe

Diagnostic Procedure 25 (Cont'd)

Perform FINAL CHECK by the following procedure after repair is completed.

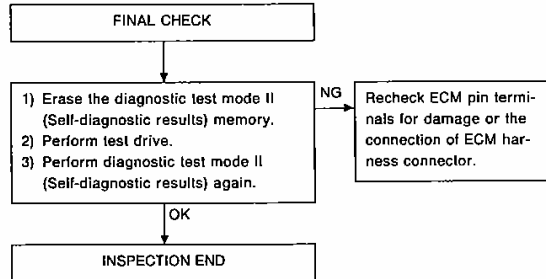

Diagnostic Procedure 26

IGNITION SIGNAL (Diagnostic trouble code No. 21)

LHD MODELS

EC-IGN/SG-01

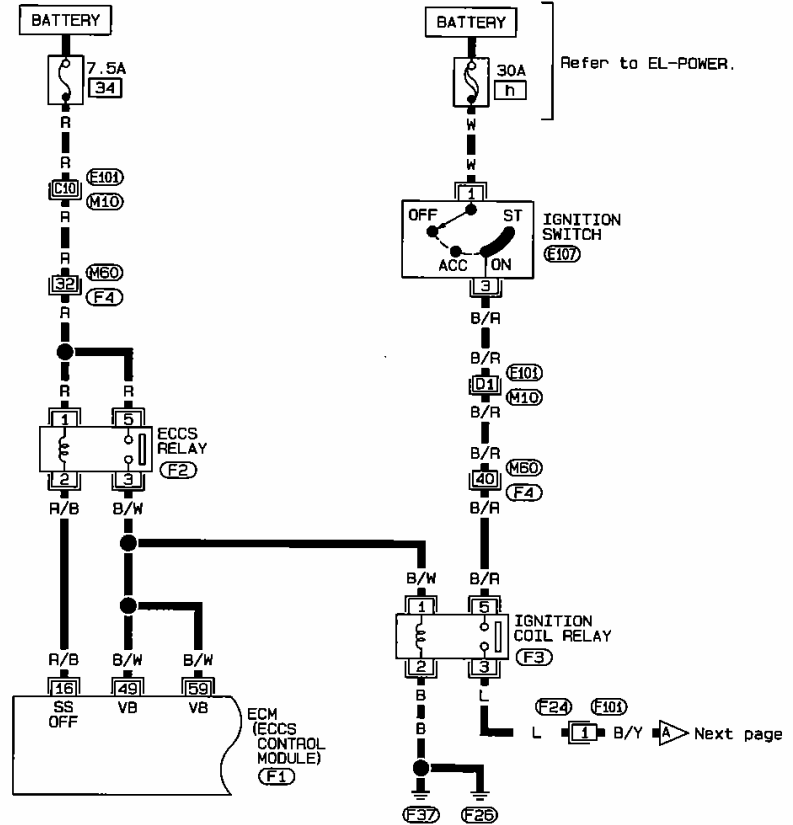

EC

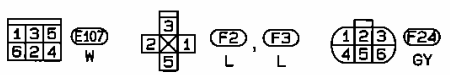

Refer to last page (Foldout page).

- M10, E101
- M60, F4

10	11	12	13	14	15	16	17	18	19	20	21	22	23	24	25	26	27	28	29	30	31	32	33	34	35	36	37	38	39	40	41	42	43	44	45	46	47	48	49	50	51	52	53	54	55	56	57	58	59	60
----	----	----	----	----	----	----	----	----	----	----	----	----	----	----	----	----	----	----	----	----	----	----	----	----	----	----	----	----	----	----	----	----	----	----	----	----	----	----	----	----	----	----	----	----	----	----	----	----	----	----



TROUBLE DIAGNOSES

Except for Europe

Diagnostic Procedure 26 (Cont'd)

EC-IGN/SG-02

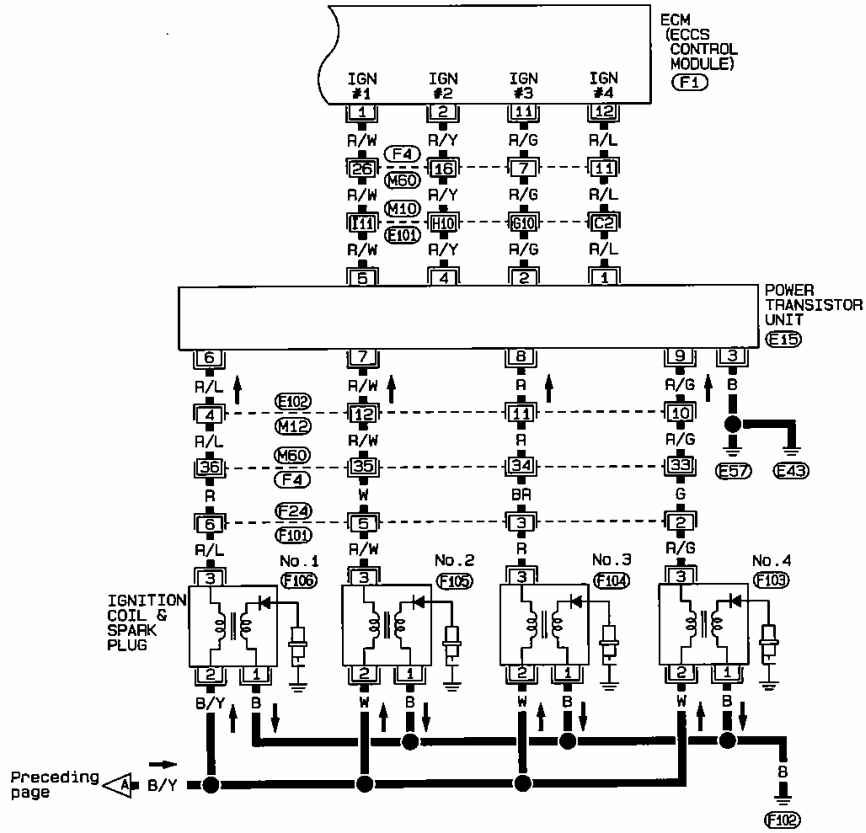

F103, F104, F105, F106 F24 E102
 1 2 3 1 2 3 4 5 1 2 3 4 5 6 7 8 9 10 11 12
 4 5 6 GY W

M10, E101
 M60, F4

E15

F1
 L

H.S.

Refer to last page (Foldout page).

10	11	12	13	14	15	16	17	18	19	20	21	22	23	24	25	26	27	28	29	30	31	32	33	34	35	36	37	38	39	40	41	42	43	44	45	46	47	48	49	50	51	52	53	54	55	56	57	58	59	60
----	----	----	----	----	----	----	----	----	----	----	----	----	----	----	----	----	----	----	----	----	----	----	----	----	----	----	----	----	----	----	----	----	----	----	----	----	----	----	----	----	----	----	----	----	----	----	----	----	----	----

TROUBLE DIAGNOSES

Except for Europe

Diagnostic Procedure 26 (Cont'd)

RHD MODELS

EC-IGN/SG-03

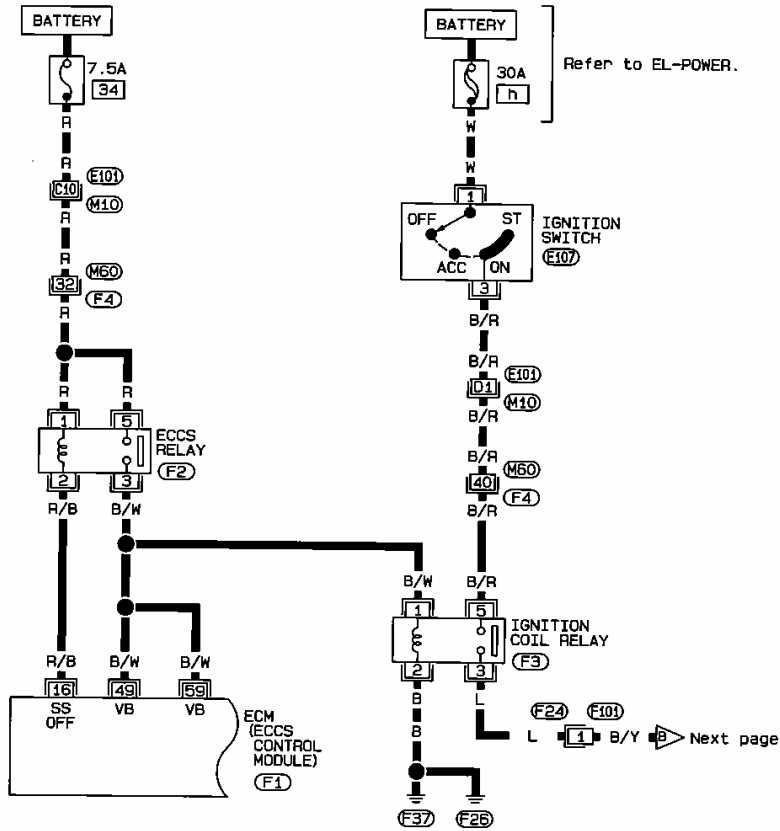

EC

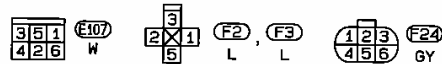

Refer to last page (Foldout page).

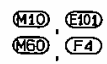

101	102	103	104	105	106	107	108	1	2	3	4	5	6	7	8	9	10	21	22	23	24	25	26	27	28	29	30	41	42	43	44	45	46	47	48	49	50	109	110	111	112	113	114	115	116	11	12	13	14	15	16	17	18	19	20	31	32	33	34	35	36	37	38	39	40	51	52	53	54	55	56	57	58	59	60
-----	-----	-----	-----	-----	-----	-----	-----	---	---	---	---	---	---	---	---	---	----	----	----	----	----	----	----	----	----	----	----	----	----	----	----	----	----	----	----	----	----	-----	-----	-----	-----	-----	-----	-----	-----	----	----	----	----	----	----	----	----	----	----	----	----	----	----	----	----	----	----	----	----	----	----	----	----	----	----	----	----	----	----



Diagnostic Procedure 26 (Cont'd)

EC-IGN/SG-04

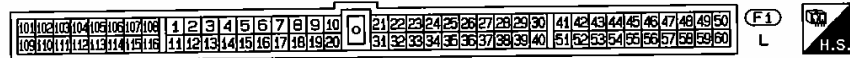
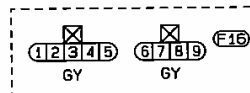
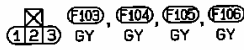
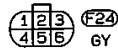
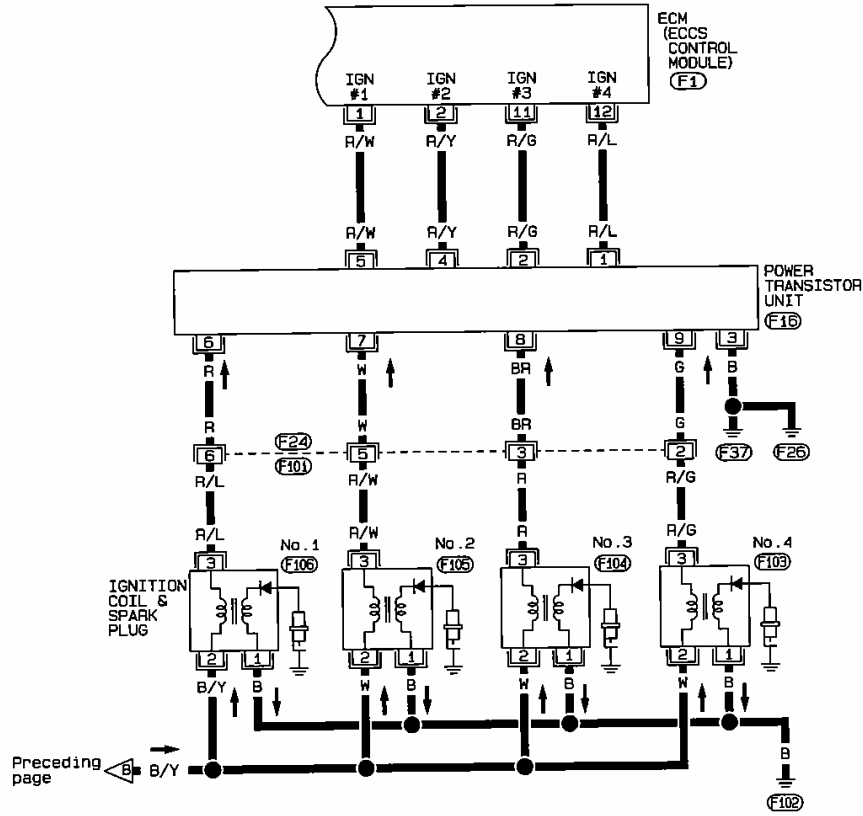

TROUBLE DIAGNOSES

Except for Europe

Diagnostic Procedure 26 (Cont'd)

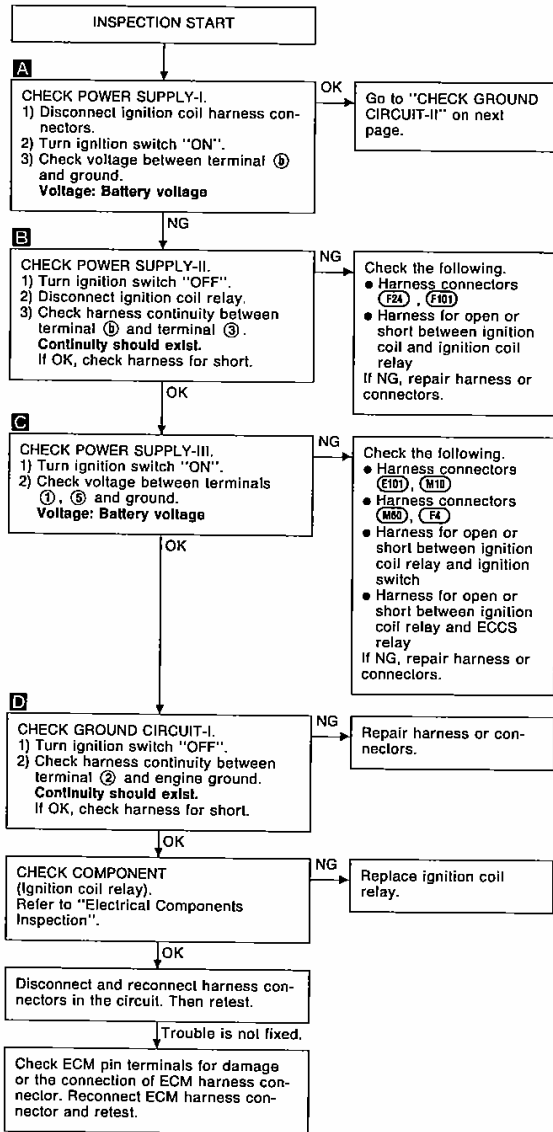
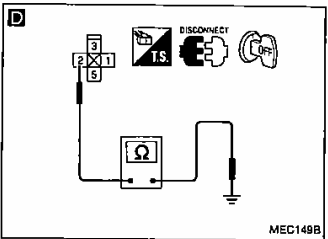
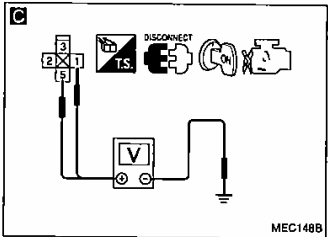
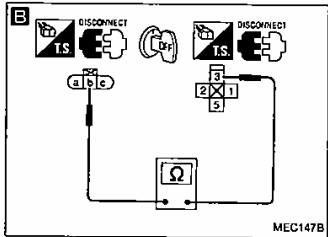
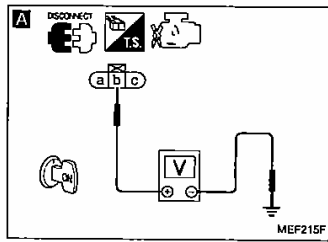

EC

TROUBLE DIAGNOSES

Except for Europe

Diagnostic Procedure 26 (Cont'd)

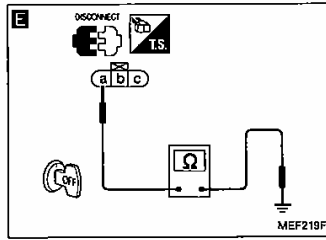

CHECK GROUND CIRCUIT-II.
 1) Turn ignition switch "OFF".
E 2) Check harness continuity between terminal ③ and engine ground.
Continuity should exist. If OK, check harness for short.
 3) Disconnect power transistor unit harness connector.
F 4) Check harness continuity between terminal ① and engine ground.
Continuity should exist. If OK, check harness for short.

NG → Repair harness or connectors.

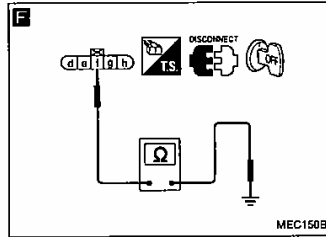

CHECK OUTPUT SIGNAL CIRCUIT.
G 1) Check harness continuity between terminals ①, ①, ①, ① and terminal ②.
Continuity should exist. If OK, check harness for short.
H 3) Check harness continuity between following terminals.
 ① - ① ① - ②
 ② - ① ② - ②
Continuity should exist. If OK, check harness for short.

NG → Check the following.
 • Harness connectors (F24, F101)
 • Harness connectors (M20, F4) (LHD models)
 • Harness connectors (E102, M12) (LHD models)
 • Harness connectors (M10, E101) (LHD models)
 • Harness for open or short between ignition coil and power transistor unit
 • Harness for open or short between ECM and power transistor unit
 If NG, repair harness or connectors.

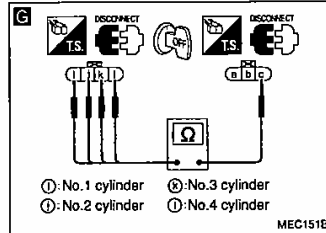

CHECK COMPONENTS (Ignition coil and power transistor unit). Refer to "Electrical Components Inspection".

NG → Replace malfunctioning component(s).

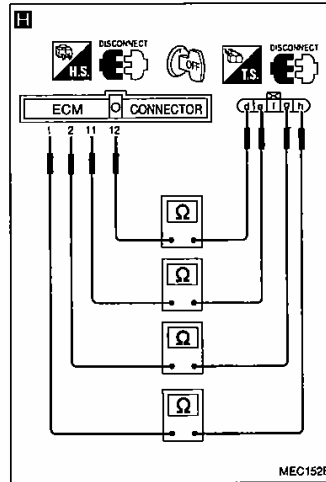

Disconnect and reconnect harness connectors in the circuit. Then retest.

Trouble is not fixed.
 Check ECM pin terminals for damage or the connection of ECM harness connector. Reconnect ECM harness connector and retest.

TROUBLE DIAGNOSES

Except for Europe

Diagnostic Procedure 26 (Cont'd)

Perform FINAL CHECK by the following procedure after repair is completed.

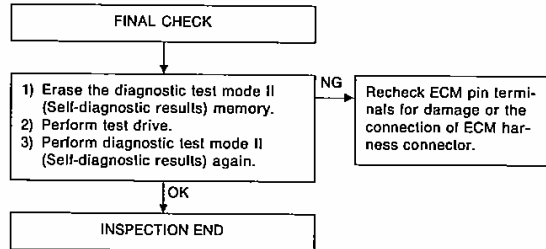

EC

Diagnostic Procedure 29

THROTTLE POSITION SENSOR (Diagnostic trouble code No. 43)

EC-TPS-01

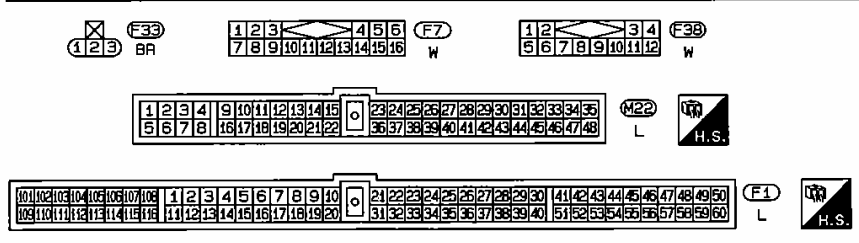
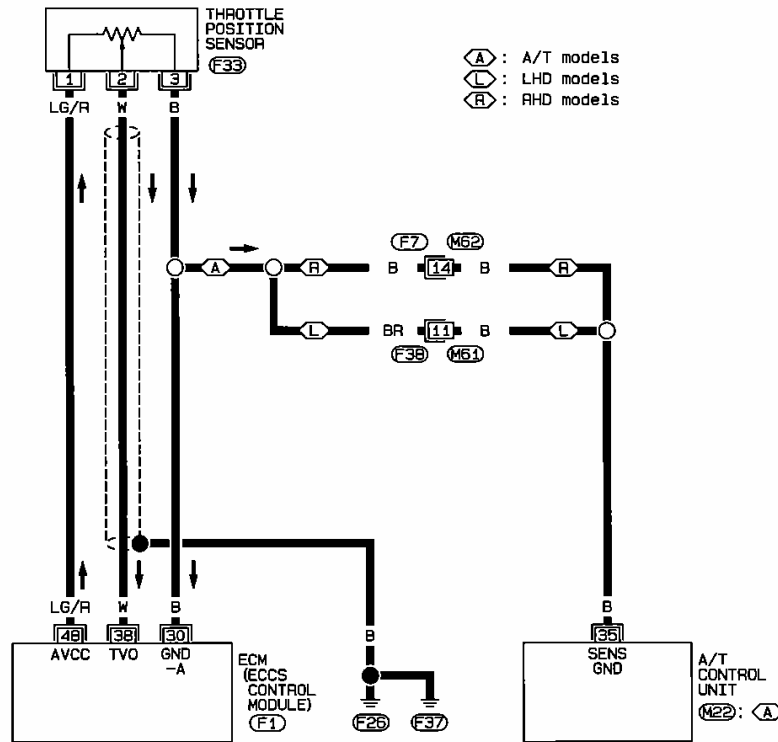

TROUBLE DIAGNOSES

Except for Europe

Diagnostic Procedure 29 (Cont'd)

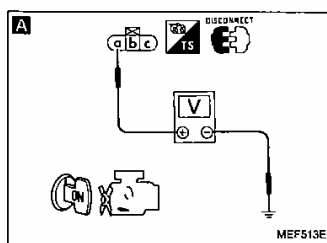

INSPECTION START

A
CHECK POWER SUPPLY.
 1) Disconnect throttle position sensor harness connector.
 2) Turn ignition switch "ON".
 3) Check voltage between terminal ① and ground.
Voltage: Approximately 5V

NG → Repair harness or connectors.

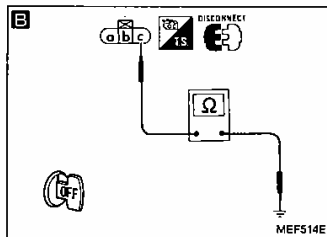

B
CHECK GROUND CIRCUIT.
 1) Turn ignition switch "OFF".
 2) Loosen and retighten ground screws.
 3) Check harness continuity between terminal ② and engine ground.
Continuity should exist.
 If OK, check harness for short.

NG → Check the following.
 • Harness connectors (F38, M61) (LHD A/T models)
 • Harness connectors (F7, M62) (RHD A/T models)
 • Harness for open or short between ECM and throttle position sensor
 • Harness for open or short between A/T control unit and throttle position sensor
 If NG, repair harness or connectors.

EC

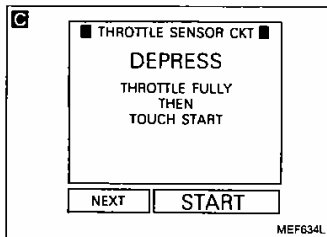

C
CHECK INPUT SIGNAL CIRCUIT.
 1) Reconnect throttle position sensor harness connector.
 2) Turn ignition switch "ON".
 3) Perform "THROTTLE SENSOR CKT" or "THROTTLE POSI SEN CKT" in "FUNCTION TEST" mode with CONSULT.

NG → Repair harness or connectors.

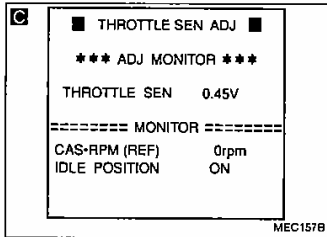

OR
 3) Read "THROTTLE SEN" or "THR TL POS SEN" signal in "WORK SUPPORT" mode with CONSULT.
Throttle valve fully closed: 0.35 - 0.65V
Throttle valve fully open: Approx. 4.0V

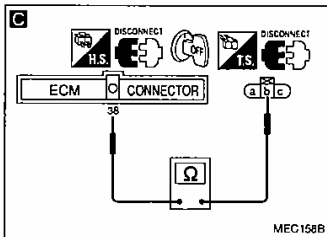

OR
 1) Disconnect ECM harness connector.
 2) Check harness continuity between ECM terminal ③ and terminal ④.
Continuity should exist.
 If OK, check harness for short.

OK
 ④

TROUBLE DIAGNOSES

Except for Europe

Diagnostic Procedure 29 (Cont'd)

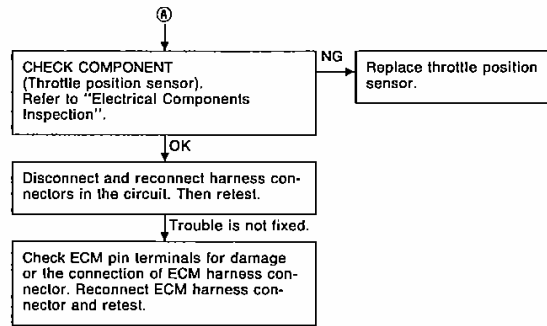

Perform FINAL CHECK by the following procedure after repair is completed.

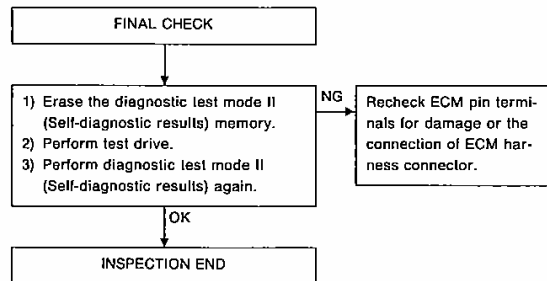

TROUBLE DIAGNOSES

Except for Europe

Diagnostic Procedure 30

A/T CONTROL (Diagnostic trouble code No. 54)

EC-AT/C-01

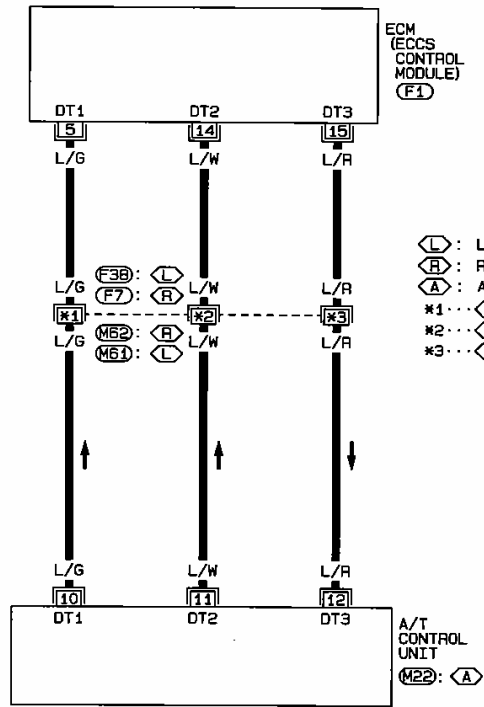

EC

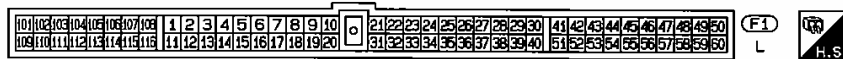
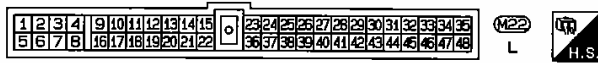
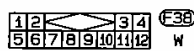
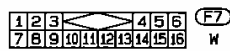

TROUBLE DIAGNOSES

Except for Europe

Diagnostic Procedure 30 (Cont'd)

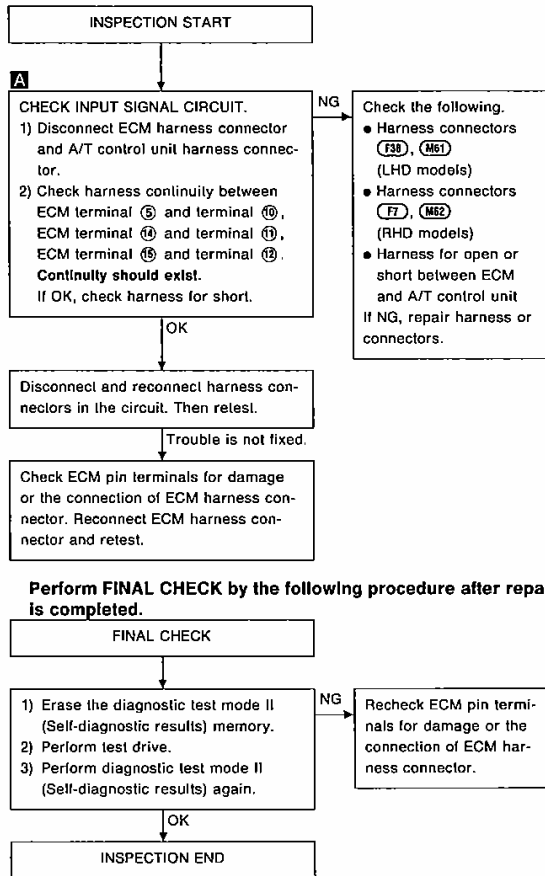
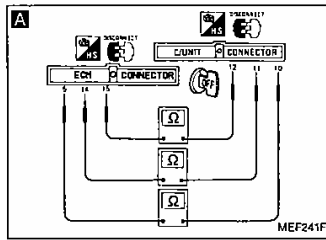

TROUBLE DIAGNOSES

Except for Europe

Diagnostic Procedure 33

EGR AND CANISTER CONTROL (Not self-diagnostic item)

EC-EGRC/V-01

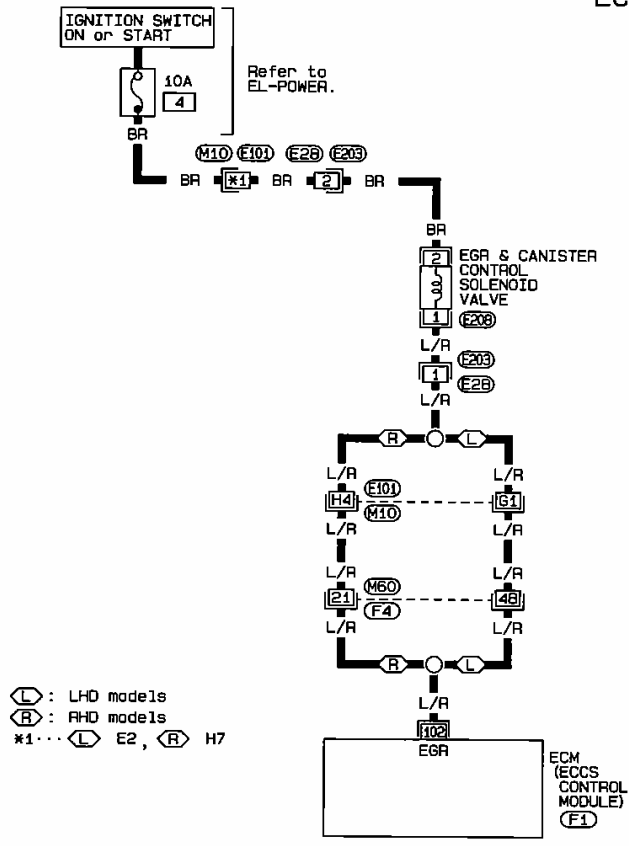

EC

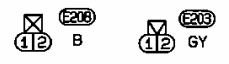

Refer to last page (Foldout page).

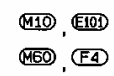

10	11	12	13	14	15	16	17	18	19	20	21	22	23	24	25	26	27	28	29	30	31	32	33	34	35	36	37	38	39	40	41	42	43	44	45	46	47	48	49	50	51	52	53	54	55	56	57	58	59	60
										F1											L	H.S.																												

TROUBLE DIAGNOSES

Except for Europe

Diagnostic Procedure 33 (Cont'd)

Harness layout

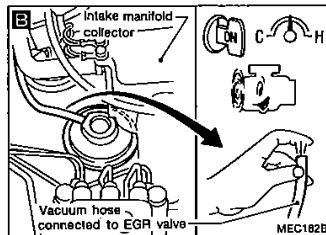
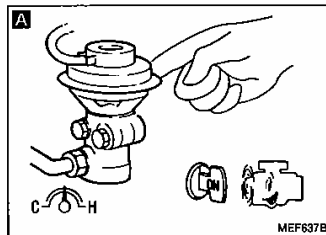
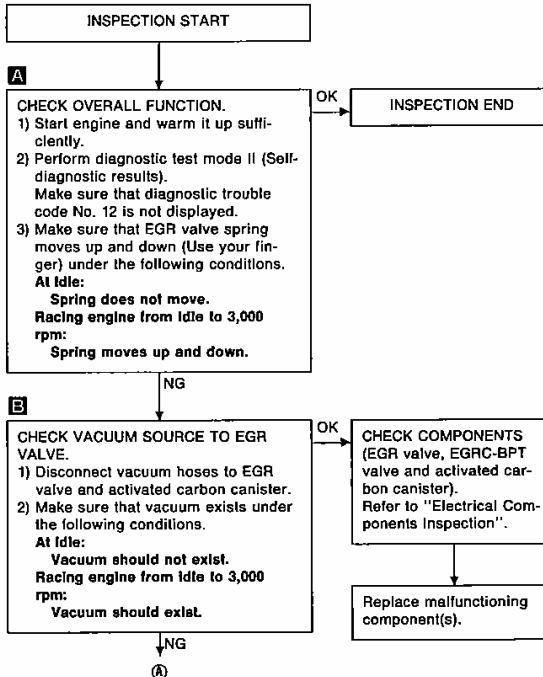
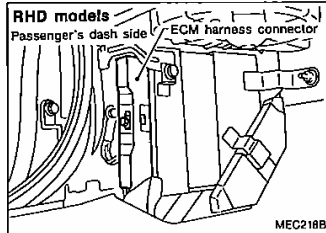
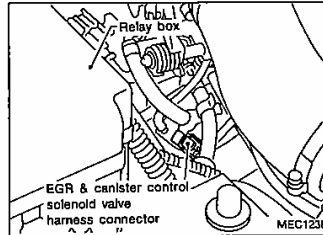
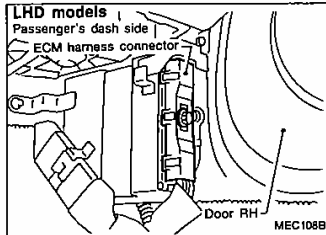

TROUBLE DIAGNOSES

Except for Europe

Diagnostic Procedure 33 (Cont'd)

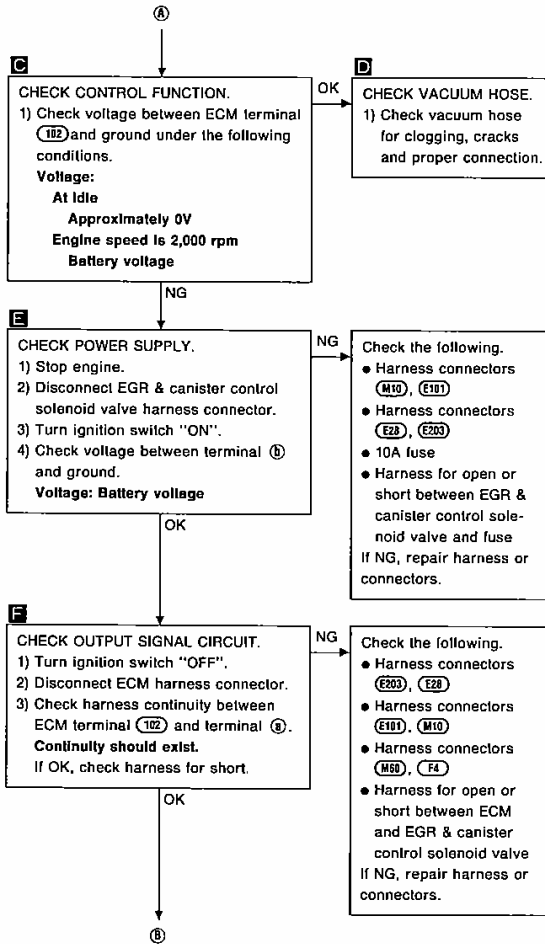
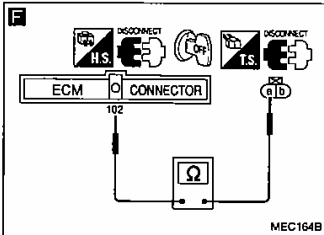
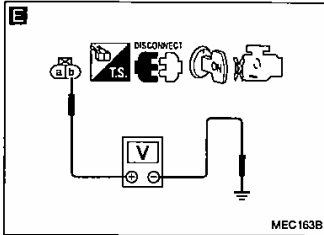
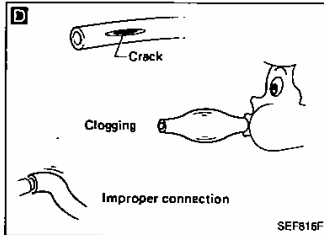
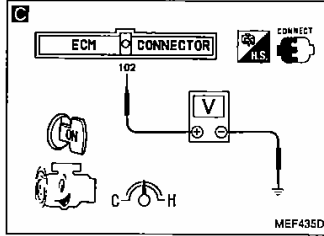
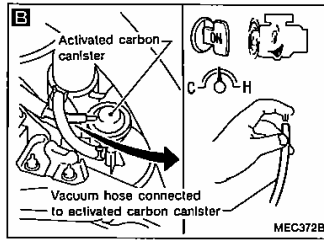

EC

Diagnostic Procedure 33 (Cont'd)

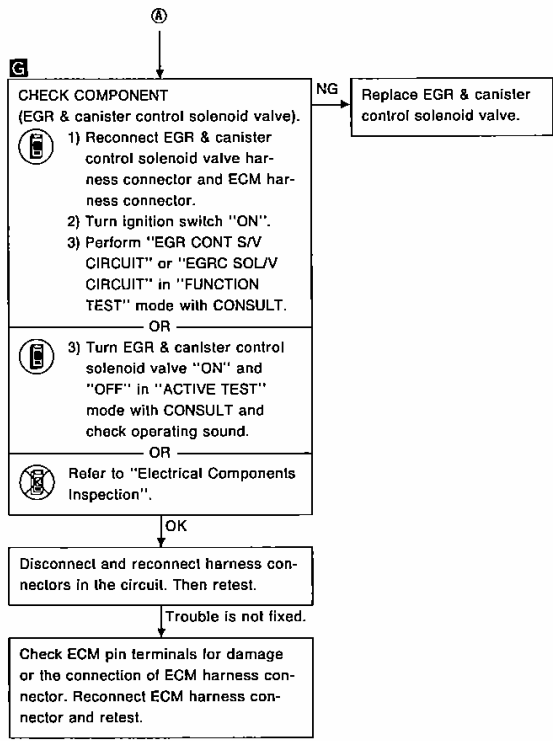
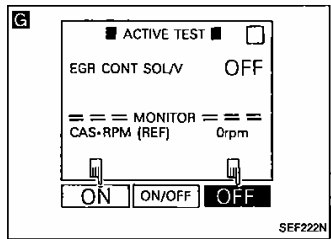
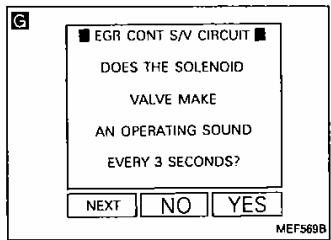

Diagnostic Procedure 34

HEATED OXYGEN SENSOR (Not self-diagnostic item)

EC-H02S-01

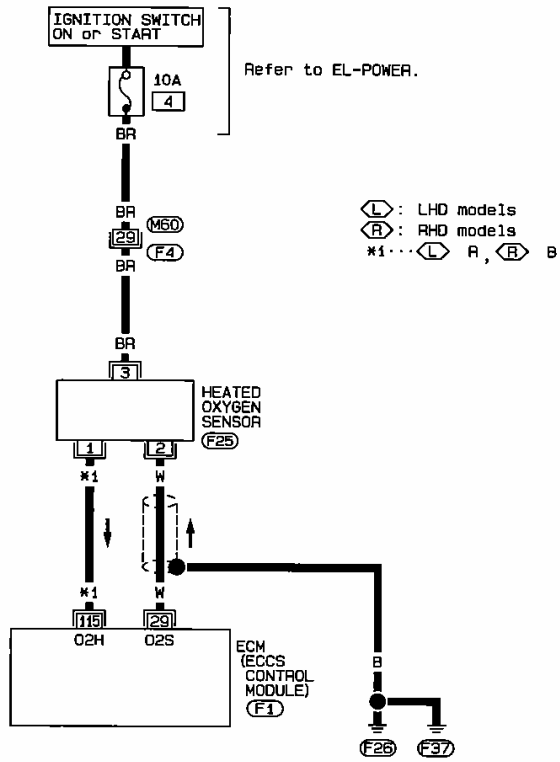

EC

◁ L : LHD models
 ▷ R : RHD models
 *1... ◁ L, ▷ R, B

123 F25
 GY

Refer to last page
 (Foldout page).

M60, F4

101	102	103	104	105	106	107	108	1	2	3	4	5	6	7	8	9	10	11	12	13	14	15	16	17	18	19	20	21	22	23	24	25	26	27	28	29	30	31	32	33	34	35	36	37	38	39	40	41	42	43	44	45	46	47	48	49	50	51	52	53	54	55	56	57	58	59	60
-----	-----	-----	-----	-----	-----	-----	-----	---	---	---	---	---	---	---	---	---	----	----	----	----	----	----	----	----	----	----	----	----	----	----	----	----	----	----	----	----	----	----	----	----	----	----	----	----	----	----	----	----	----	----	----	----	----	----	----	----	----	----	----	----	----	----	----	----	----	----	----

F1
 L



Diagnostic Procedure 35

INJECTOR CIRCUIT (Not self-diagnostic item)

EC-INJECT-01

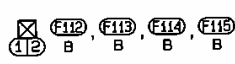
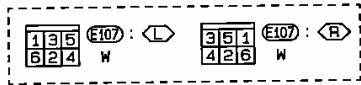
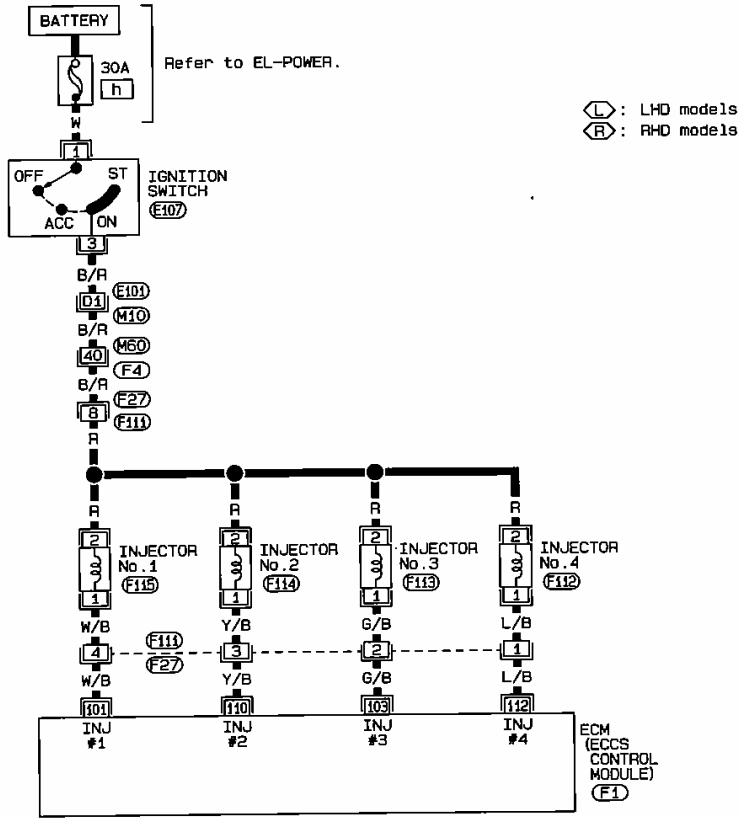

Refer to last page (Foldout page).

M10, E101
 M50, F4



Diagnostic Procedure 36

FUEL PUMP (Not self-diagnostic item)

EC-F/PUMP-01

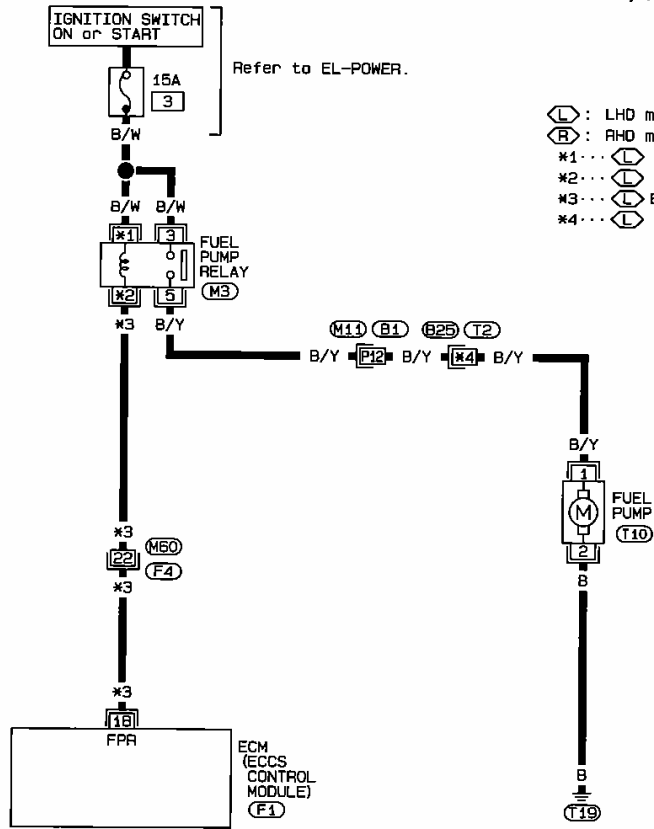

Refer to EL-POWER.

- ◁ LHD models
- ◁ RHD models
- *1... ◁ 1, ▷ 2
- *2... ◁ 2, ▷ 1
- *3... ◁ B/P, ▷ B/Y
- *4... ◁ 1, ▷ 3

EC

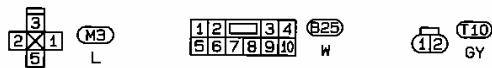

Refer to last page (Foldout page).

- ◁ M11, ▷ B1
- ◁ M50, ▷ F4

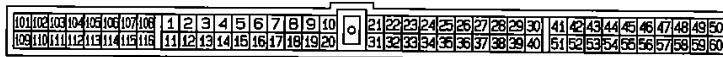

TROUBLE DIAGNOSES

Except for Europe

Diagnostic Procedure 36 (Cont'd)

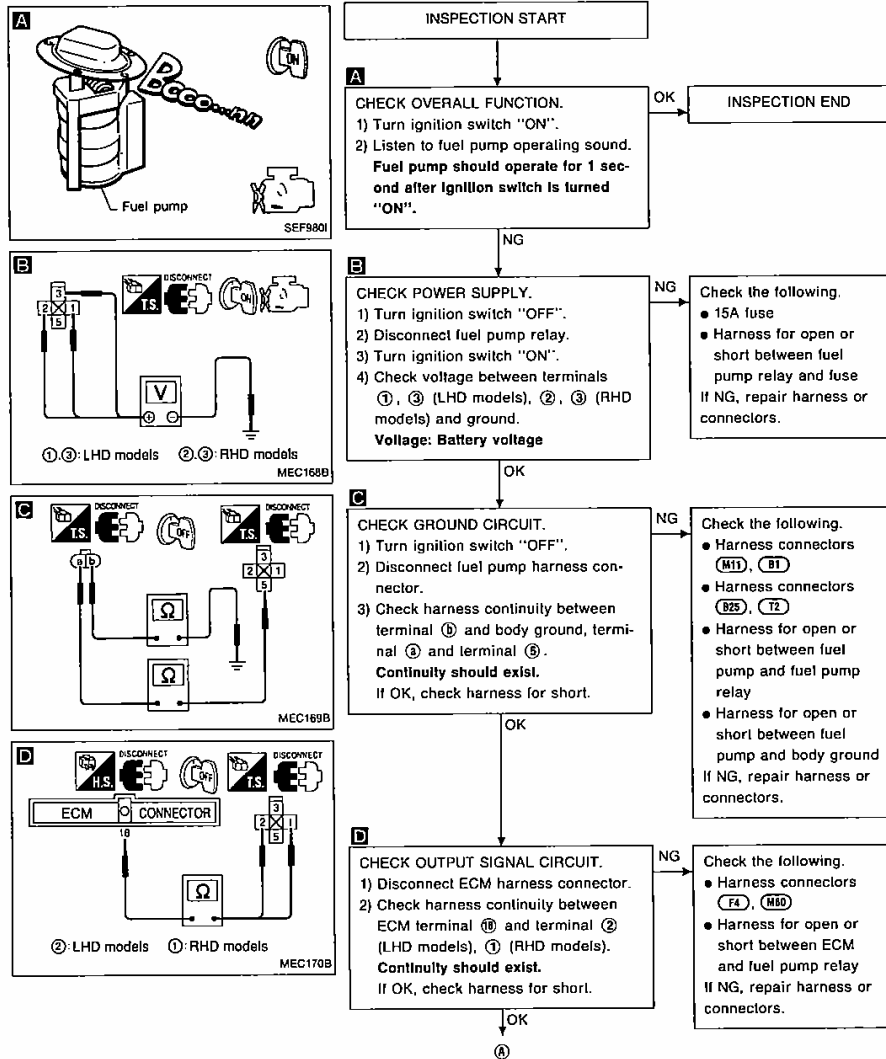

TROUBLE DIAGNOSES

Except for Europe

Diagnostic Procedure 36 (Cont'd)

E

■ FUEL PUMP CIRCUIT ■
 PINCH FUEL FEED HOSE WITH FINGERS. IS THERE ANY PRESSURE PULSATION ON THE FUEL FEED HOSE?
 OR
 DOES THE FUEL PUMP RELAY MAKE AN OPERATING SOUND EVERY 3 SECONDS?

NEXT NO YES

SEF194L

E

■ ACTIVE TEST ■

FUEL PUMP RELAY ON

== MONITOR ==
 CAS-RPM (REF) 0rpm

ON ON/OFF OFF

SEF498L

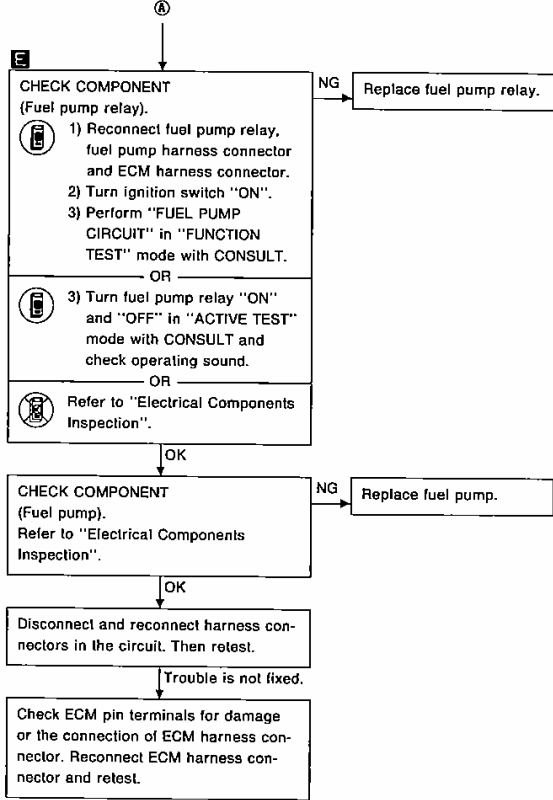

Diagnostic Procedure 40

IACV-FICD SOLENOID VALVE (Not self-diagnostic item)

LHD MODELS

EC-FICD-01

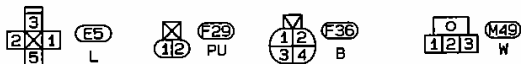
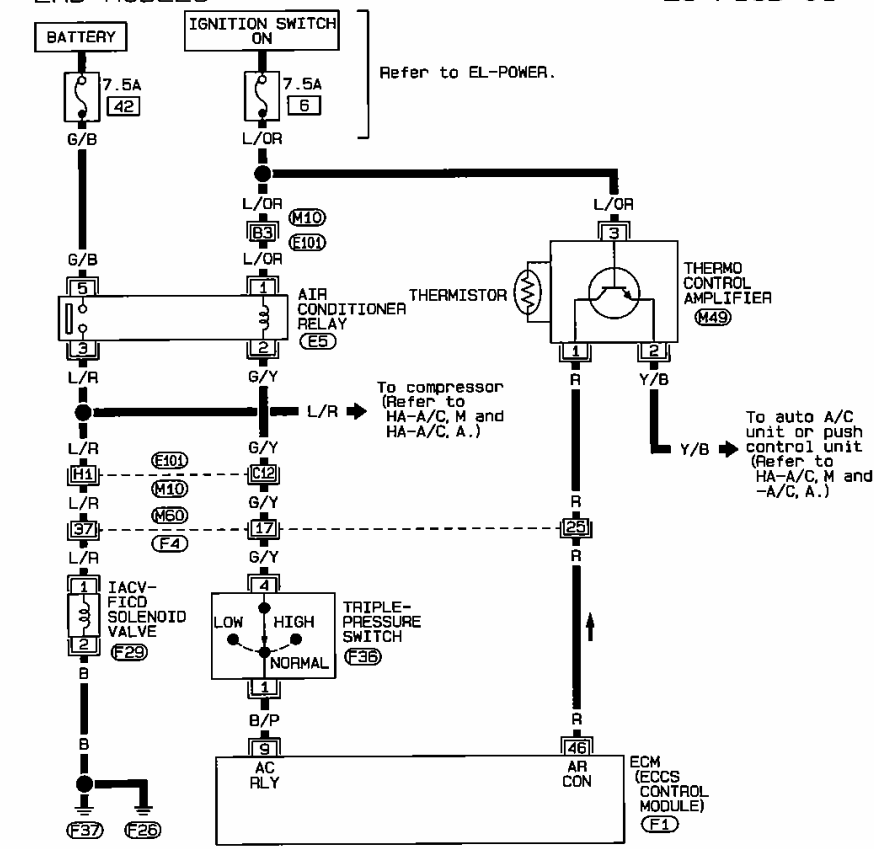

Refer to last page (Foldout page).

M10, E101
M60, F4

101	102	103	104	105	106	107	108	1	2	3	4	5	6	7	8	9	10	21	22	23	24	25	26	27	28	29	30	41	42	43	44	45	46	47	48	49	50
109	110	111	112	113	114	115	116	11	12	13	14	15	16	17	18	19	20	31	32	33	34	35	36	37	38	39	40	51	52	53	54	55	56	57	58	59	60

F1 L H.S.

TROUBLE DIAGNOSES

Except for Europe

Diagnostic Procedure 40 (Cont'd)

RHD MODELS

EC-FICD-02

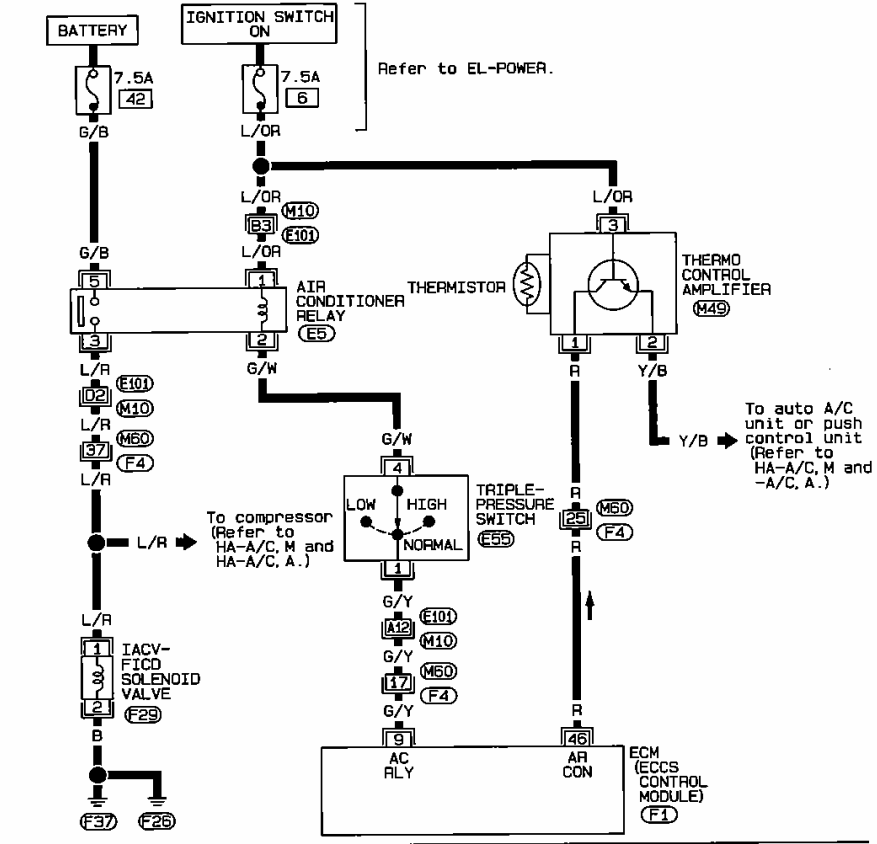

EC

To auto A/C unit or push control unit (Refer to HA-A/C, M and -A/C, A.)

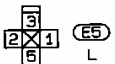

Refer to last page (Foldout page).



101	102	103	104	105	106	107	108	1	2	3	4	5	6	7	8	9	10	0	21	22	23	24	25	26	27	28	29	30	41	42	43	44	45	46	47	48	49	50	F1	H.S.
109	110	111	112	113	114	115	116	11	12	13	14	15	16	17	18	19	20	31	32	33	34	35	36	37	38	39	40	51	52	53	54	55	56	57	58	59	60	L		

Diagnostic Procedure 43

NEUTRAL POSITION SWITCH & A/T CONTROL UNIT (PARK/NEUTRAL POSITION SIGNAL)
(Not self-diagnostic item)

EC-PNP/SW-01

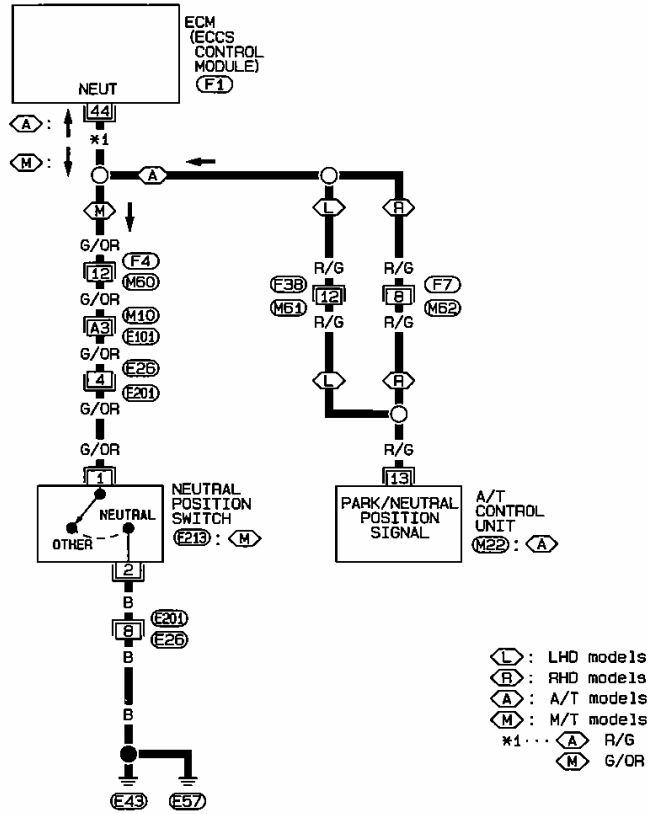

- ◁ L : LHD models
- ◁ R : RHD models
- ◁ A : A/T models
- ◁ M : M/T models
- *1... ◁ A R/G
- ◁ M G/OR

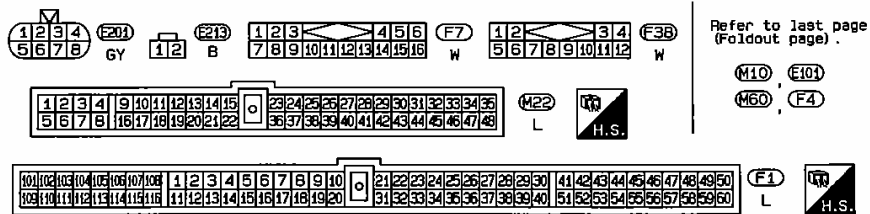

Refer to last page (Foldout page).

M10, E101
M60, F4

TROUBLE DIAGNOSES

Except for Europe

Diagnostic Procedure 43 (Cont'd)

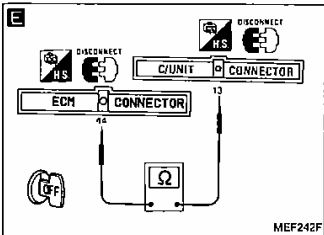
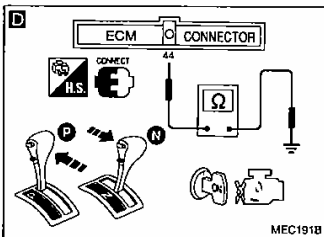
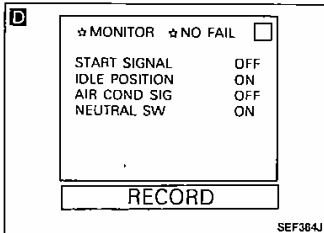
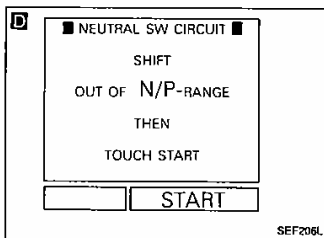

A/T CONTROL UNIT (PARK/NEUTRAL POSITION SIGNAL) CIRCUIT

INSPECTION START

D CHECK OVERALL FUNCTION.

1) Turn ignition switch "ON".

2) Perform "NEUTRAL SW CIRCUIT" or "NEUTRAL POSI SW CKT" in "FUNCTION TEST" mode with CONSULT.

OR

2) Check "NEUTRAL SW" or "NEUT POSI SW" signal in "DATA MONITOR" mode with CONSULT.

"N" or "P": ON
Except above: OFF

OR

2) Check voltage between ECM terminal ④ and ground under the following conditions.

Voltage:
"N" or "P": Approximately 0V
Except above: Approximately 5V

OK → INSPECTION END

E CHECK INPUT SIGNAL CIRCUIT.

1) Turn ignition switch "OFF".

2) Disconnect ECM harness connector.

3) Disconnect A/T control unit harness connector.

4) Check harness continuity between ECM terminal ④ and terminal ③. Continuity should exist. If OK, check harness for short.

NG → Check the following.

- Harness connectors (E39, M61) (LHD models)
- Harness connectors (F7, M62) (RHD models)
- Harness for open or short between ECM and A/T control unit

If NG, repair harness or connectors.

NG CHECK INHIBITOR SWITCH FUNCTION. Make sure that inhibitor switch functions properly. (Refer to AT section).

NG → Check inhibitor switch and circuit (Refer to AT section.)

OK → Disconnect and reconnect harness connectors in the circuit. Then retest.

Trouble is not fixed.

Check ECM pin terminals for damage or the connection of ECM harness connector. Reconnect ECM harness connector and retest.

EC

TROUBLE DIAGNOSES

Electrical Components Inspection

ECM HARNESS CONNECTOR TERMINAL LAYOUT

For Europe

101	102	103	105	106	107	108	1	2	3	4	5	6	7	○	15	16	17	18	19	20	21	22	31	32	33	34	35	36	37	38	39
109	110	111	112	113	114	116	8	9	10	11	12	13	14	○	23	24	25	26	27	28	30	40	41	43	44	45	46	47	48		



SEF632R

Except for Europe

101	102	103	105	107	108	1	2	4	5	7	9	10	○	21	22	23	25	26	27	28	29	30	41	42	43	44	45	46	47	48	49	50
109	110	112	113	115	116	11	12	14	15	16	18	19	20	○	31	32	33	34	36	38	39	51	52	53	54	56	58	59	60			



SEF633R

TROUBLE DIAGNOSES

Electrical Components Inspection (Cont'd)

ECM INSPECTION TABLE (For Europe)

*Data are reference values.

TER-MINAL NO.	ITEM	CONDITION	*DATA
1 3 5 25	Ignition signal	Engine is running. └ Idle speed	0 - 0.1V
		Engine is running. └ Engine speed is 2,000 rpm.	Approximately 0.2V
2	Tachometer	Engine is running. └ Idle speed	Approximately 1V
4	ECCS relay (Self-shutoff)	Engine is running. Ignition switch "OFF" └ For a few seconds after turning ignition switch "OFF"	Approximately 1V
		Ignition switch "OFF" └ A few seconds after turning ignition switch "OFF" and thereafter	BATTERY VOLTAGE (11 - 14V)
9	Cooling fan relay (Low speed)	Engine is running. └ Cooling fan is not operating.	BATTERY VOLTAGE (11 - 14V)
		Engine is running. └ Cooling fan is operating.	Approximately 0.1V
10	Cooling fan relay (High speed)	Engine is running. └ Cooling fan is not operating. Cooling fan is operating at low speed.	BATTERY VOLTAGE (11 - 14V)
		Engine is running. └ Cooling fan is operating at high speed.	Approximately 0.1V
11	Air conditioner relay	Engine is running. └ Both A/C switch and blower switch are "ON".	Approximately 0.1V
		Engine is running. └ A/C switch is "OFF".	BATTERY VOLTAGE (11 - 14V)
16	Mass air flow sensor	Engine is running. (Warm-up condition) └ Idle speed	0.8 - 1.5V
		Engine is running. (Warm-up condition) └ Engine speed is 3,000 rpm.	1.4 - 2.0V
18	Engine coolant temperature sensor	Engine is running.	0 - 5.0V Output voltage varies with engine coolant temperature.

EC

TROUBLE DIAGNOSES

Electrical Components Inspection (Cont'd)

*Data are reference values.

TER-MINAL NO.	ITEM	CONDITION	*DATA
19	Heated oxygen sensor	Engine is running. └ Engine speed is 2,000 rpm after warming up sufficiently.	0 - 0.3V ↔ 0.6 - 0.9V
20	Throttle position sensor	Ignition switch "ON" └ Accelerator pedal released	0.35 - 0.65V
		Ignition switch "ON" └ Accelerator pedal fully depressed	Approximately 3V
22 30	Camshaft position sensor (Position signal)	Engine is running.	2.0 - 3.0V
27	Knock sensor	Engine is running. └ Idle speed	2.0 - 3.0V
31 40	Camshaft position sensor (Reference signal)	Engine is running.	Approximately 0.6V
33	Load signal	Ignition switch "ON" └ Rear window defogger switch is "ON".	BATTERY VOLTAGE (11 - 14V)
34	Start signal	Ignition switch "ON"	Approximately 0V
		Ignition switch "START"	BATTERY VOLTAGE (11 - 14V)
35	Neutral position/Inhibitor switch	Ignition switch "ON" └ Neutral position (M/T models) └ "N" or "P" position (A/T models)	0V
		Ignition switch "ON" └ Except the above gear position	Approximately 5V
36	Ignition switch	Ignition switch "OFF"	0V
		Ignition switch "ON"	BATTERY VOLTAGE (11 - 14V)
37	Throttle position sensor power supply	Ignition switch "ON"	Approximately 5V
38 47	Power supply for ECM	Ignition switch "ON"	BATTERY VOLTAGE (11 - 14V)
41	Air conditioner switch	Engine is running. └ Both air conditioner switch and blower switch are "ON".	Approximately 0V
		Engine is running. └ Air conditioner switch is "OFF".	BATTERY VOLTAGE (11 - 14V)

TROUBLE DIAGNOSES

Electrical Components Inspection (Cont'd)

*Data are reference values.

TER-MINAL NO.	ITEM	CONDITION	*DATA
43	Power steering oil pressure switch	Engine is running. └ Steering wheel is being turned.	Approximately 0V
		Engine is running. └ Steering wheel is not being turned.	4 - 5V
46	Power supply (Back-up)	Ignition switch "OFF"	BATTERY VOLTAGE (11 - 14V)
101	Injector No. 1	Engine is running.	BATTERY VOLTAGE (11 - 14V)
103	Injector No. 3		
110	Injector No. 2		
112	Injector No. 4		
102	Wastegate valve control solenoid valve	Engine is running. └ Idle speed	BATTERY VOLTAGE (11 - 14V)
		Engine is running. └ Revving engine up to 5,000 rpm.	Approximately 5V
105	EGR valve & canister control solenoid valve	Engine is running. (Warm-up condition) └ Idle speed	Approximately 0V
		Engine is running. (Warm-up condition) └ Engine speed is 2,000 rpm	BATTERY VOLTAGE (11 - 14)
106	Fuel pump relay	Ignition switch "ON" └ For 5 seconds after turning ignition switch "ON"	Approximately 0V
		Engine is running. Ignition switch "ON" └ 5 seconds after turning ignition switch "ON" and thereafter	BATTERY VOLTAGE (11 - 14V)
111	Heated oxygen sensor heater	Engine is running. └ Engine speed is below 4,000 rpm.	Approximately 0V
		Engine is running. └ Engine speed is above 4,000 rpm.	BATTERY VOLTAGE (11 - 14V)
113	IACV-AAC valve	Engine is running. └ Idle speed	9 - 14V
		Engine is running. └ Steering wheel is being turned. └ Air conditioner is operating. └ Rear defogger is "ON".	5 - 9V

EC

TROUBLE DIAGNOSES**Electrical Components Inspection (Cont'd)**

*Data are reference values.

TER-MINAL NO.	ITEM	CONDITION	*DATA
114	VTC solenoid valve	<input type="checkbox"/> Engine is running. (Jacked-up condition) <input type="checkbox"/> Idle speed	BATTERY VOLTAGE (11 - 14V)
		<input type="checkbox"/> Engine is running. <input type="checkbox"/> Engine speed is above 1,050 rpm	Approximately 4V

TROUBLE DIAGNOSES

Electrical Components Inspection (Cont'd)

MASS AIR FLOW SENSOR

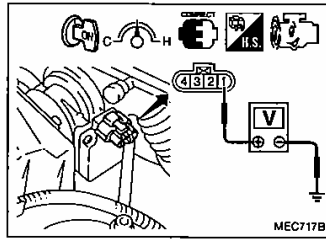

1. Fold back mass air flow sensor harness connector rubber as shown in the figure if the harness connector is connected.
2. Turn ignition switch "ON".
3. Start engine and warm it up sufficiently.
4. Check voltage between terminal ① and ground.

Conditions	Voltage V
Idle speed	0.8 - 1.5
3,000 rpm	1.4 - 2.0

5. If NG, remove mass air flow sensor from air duct. Check hot film for damage or dust.

EC

MANUAL TRANSMISSION

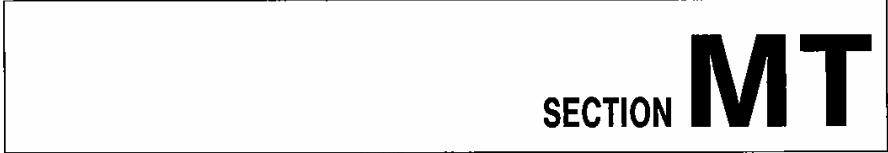

MODIFICATION NOTICE:

The service data and specifications (SDS), case and gear components have been changed.

CONTENTS

MAJOR OVERHAUL	2	SERVICE DATA AND SPECIFICATIONS (SDS)	4
Case Components.....	2	General Specifications.....	4
Gear Components.....	3	Inspection and Adjustment.....	5



MAJOR OVERHAUL

Case Components

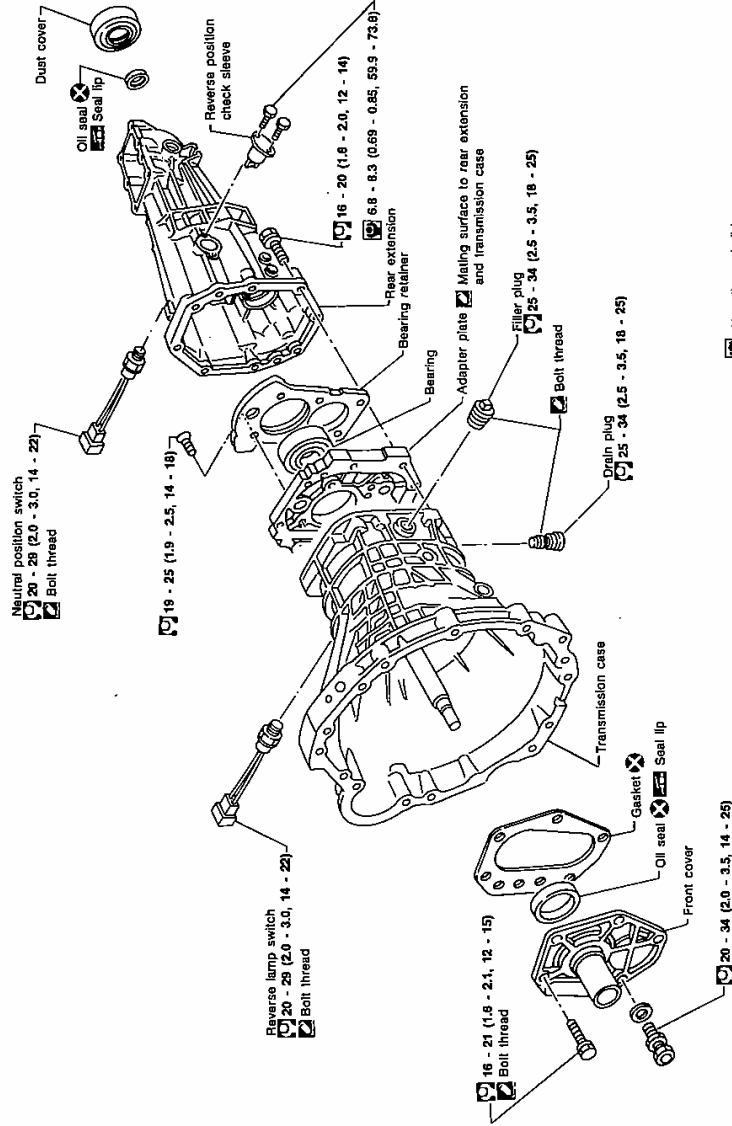

- [] N-m (kg-m, in-lb)
- [] N-m (kg-m, ft-lb)
- [] Apply recommended sealant (Nissan genuine part: KPS10-00250) or equivalent.

SEC. 320-321

MT-2

SMT1677CA

MAJOR OVERHAUL

Gear Components

SEC. 322

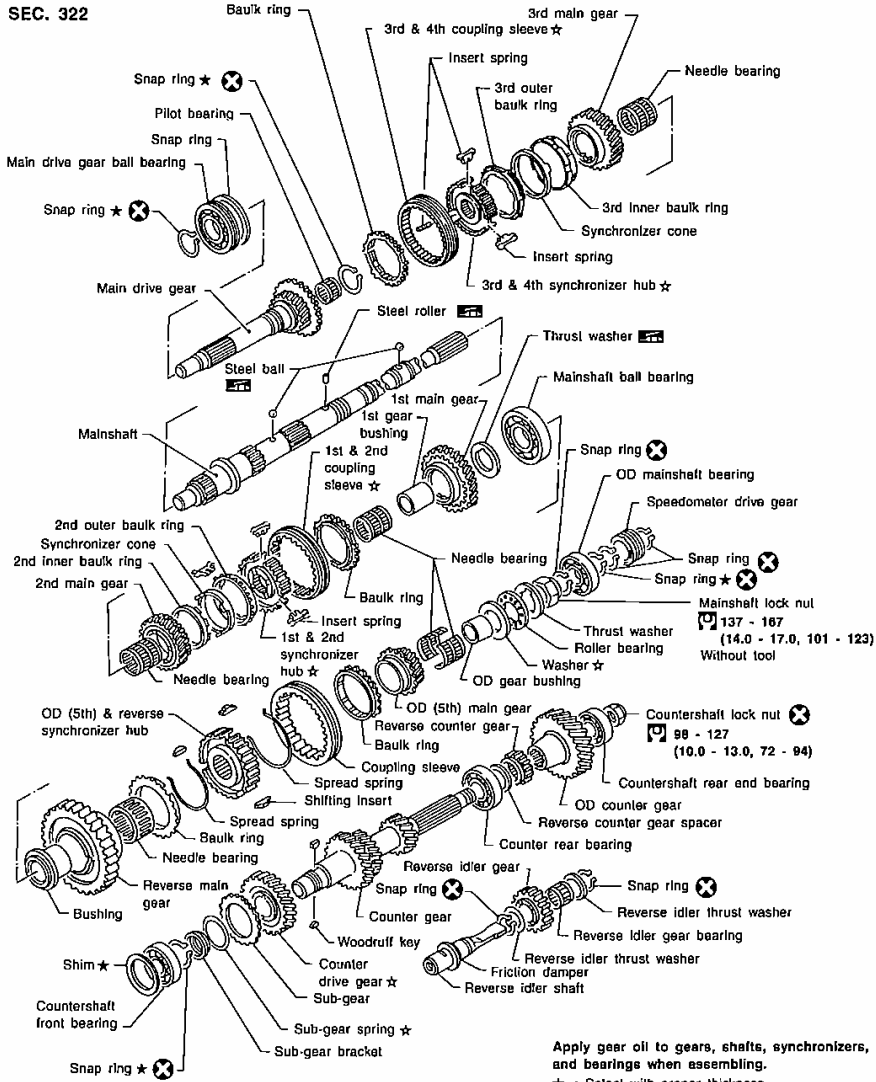

Apply gear oil to gears, shafts, synchronizers, and bearings when assembling.
 ☆ : Select with proper thickness.
 ☆ : Pay attention to its direction.
 □ : N*m (kg-m, ft-lb)

MT

SERVICE DATA AND SPECIFICATIONS (SDS)

General Specifications

Transmission model		FS5W71C
Number of speeds		5
Shift pattern		
Synchronmesh type		Warner
Gear ratio	1st	3.321
	2nd	1.902
	3rd	1.308
	4th	1.000
	OD	0.838
	Reverse	3.382
Number of teeth		
Mainshaft	Drive	22
	1st	33
	2nd	27
	3rd	26
	OD	22
	Reverse	36
Countershaft	Drive	31
	1st	14
	2nd	20
	3rd	28
	OD	37
	Reverse	15
Reverse idler gear		21
Oil capacity ℓ (Imp pt)		2.5 (4-3/8)
Remarks	Sub-gear	○
	Reverse synchronizer	○
	Double baulk ring type synchronizer	2nd and 3rd synchronizer

SERVICE DATA AND SPECIFICATIONS (SDS)

Inspection and Adjustment

GEAR END PLAY

Gear	End play mm (in)
1st gear	0.31 - 0.41 (0.0122 - 0.0161)
2nd gear	0.11 - 0.21 (0.0043 - 0.0083)
3rd gear	0.11 - 0.21 (0.0043 - 0.0083)
OD gear	0.24 - 0.41 (0.0094 - 0.0161)

CLEARANCE BETWEEN BAULK RING AND GEAR

1st, main drive, OD and reverse baulk ring

Unit: mm (in)

	Standard	Wear limit
1st	1.2 - 1.6 (0.047 - 0.063)	0.8 (0.031)
Main drive	1.2 - 1.6 (0.047 - 0.063)	
OD	1.2 - 1.6 (0.047 - 0.063)	
Reverse	1.10 - 1.55 (0.0433 - 0.0610)	0.7 (0.028)

2nd and 3rd baulk ring

Unit: mm (in)

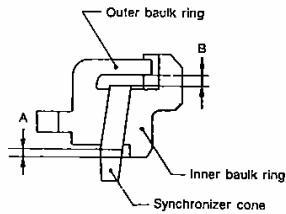

Dimension	Standard	Wear limit
A	0.7 - 0.9 (0.028 - 0.035)	0.2 (0.008)
B	0.6 - 1.1 (0.024 - 0.043)	

AVAILABLE SNAP RINGS

Main drive gear bearing

Allowable clearance	0 - 0.13 mm (0 - 0.0051 in)
Thickness mm (in)	Part number
1.87 (0.0738)	32204-76001
1.94 (0.0764)	32204-76002
2.01 (0.0791)	32204-76003

Mainshaft front

Allowable clearance	0 - 0.18 mm (0 - 0.0071 in)
Thickness mm (in)	Part number
2.4 (0.094)	32263-V5200
2.5 (0.098)	32263-V5201

OD mainshaft bearing

Allowable clearance	0 - 0.14 mm (0 - 0.0055 in)
Thickness mm (in)	Part number
1.1 (0.043)	32228-20100
1.2 (0.047)	32228-20101
1.3 (0.051)	32228-20102
1.4 (0.055)	32228-20103

Counter drive gear

Allowable clearance	0 - 0.13 mm (0 - 0.0051 in)
Thickness mm (in)	Part number
1.4 (0.055)	32215-E9000
1.5 (0.059)	32215-E9001
1.6 (0.063)	32215-E9002

MT

SERVICE DATA AND SPECIFICATIONS (SDS)

Inspection and Adjustment (Cont'd)

AVAILABLE SHIMS

Counter front bearing

Unit: mm (in)

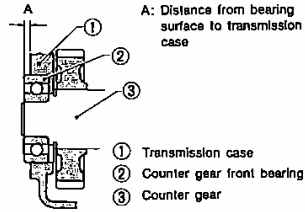

TM371

Allowable clearance	0 - 0.16 (0 - 0.0063)	
"A"	Thickness of shim	Part number
4.52 - 4.71 (0.1780 - 0.1854)	Not necessary	
4.42 - 4.51 (0.1740 - 0.1776)	0.1 (0.004)	32218-V5000
4.32 - 4.41 (0.1701 - 0.1736)	0.2 (0.008)	32218-V5001
4.22 - 4.31 (0.1661 - 0.1697)	0.3 (0.012)	32218-V5002
4.12 - 4.21 (0.1622 - 0.1657)	0.4 (0.016)	32218-V5003
4.02 - 4.11 (0.1583 - 0.1618)	0.5 (0.020)	32218-V5004
3.92 - 4.01 (0.1543 - 0.1579)	0.6 (0.024)	32218-V5005

AUTOMATIC TRANSMISSION

SECTION **AT**

MODIFICATION NOTICE:

- The wiring diagrams and service data and specifications (SDS) have been changed.

CONTENTS

TROUBLE DIAGNOSES	2	SERVICE DATA AND SPECIFICATIONS (SDS)	15
Circuit Diagram for Quick Pinpoint Check	2	General Specifications	15
Wiring Diagram — AT —	3	Specifications and Adjustment	15



TROUBLE DIAGNOSES

Circuit Diagram for Quick Pinpoint Check

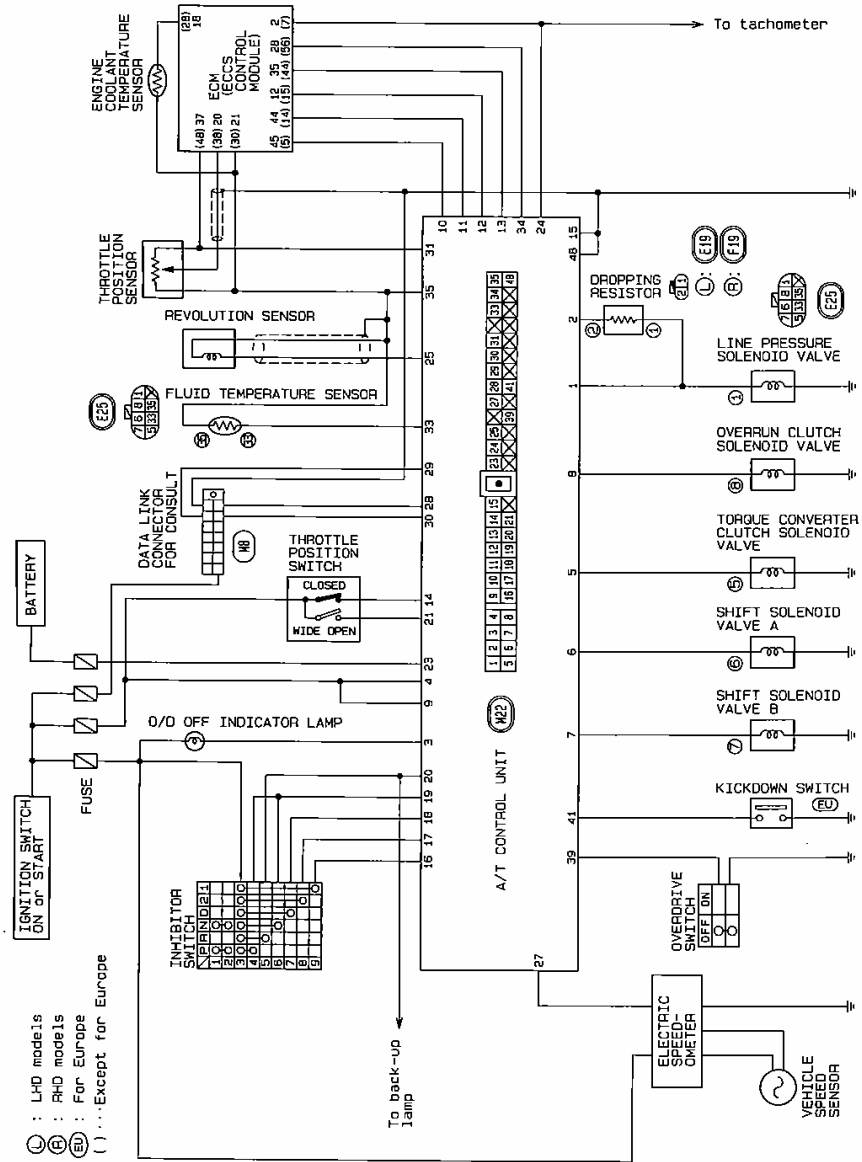

TROUBLE DIAGNOSES

Wiring Diagram — AT —

LHD MODELS

AT-A/T-01

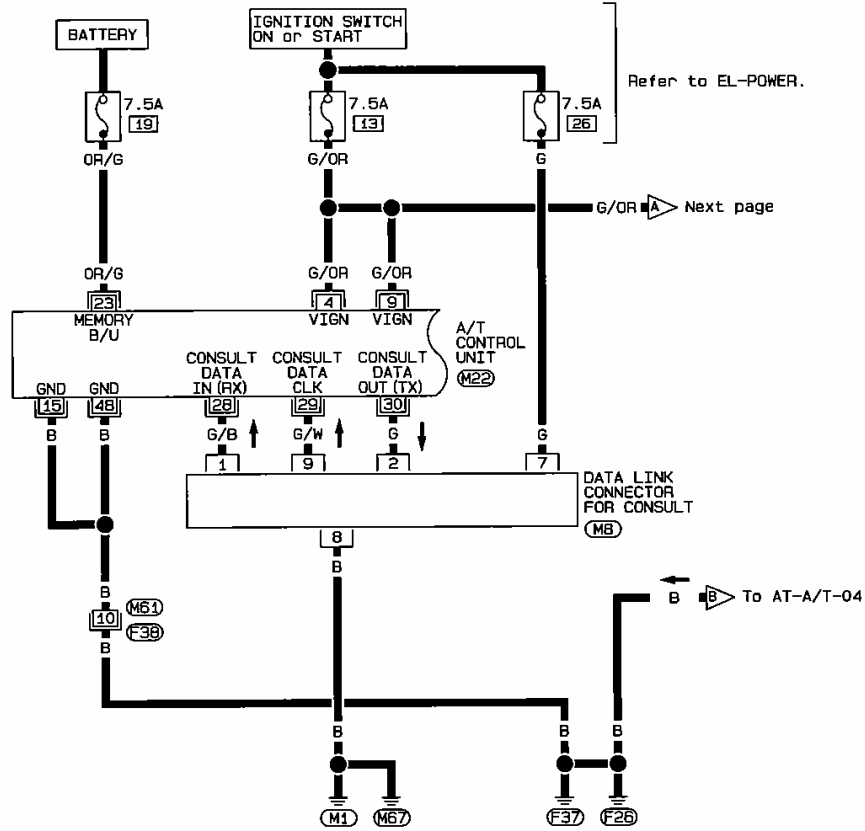

AT

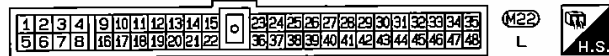

TROUBLE DIAGNOSES

Wiring Diagram — AT — (Cont'd)

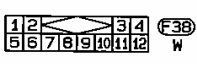
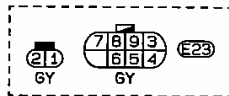
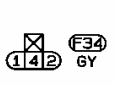
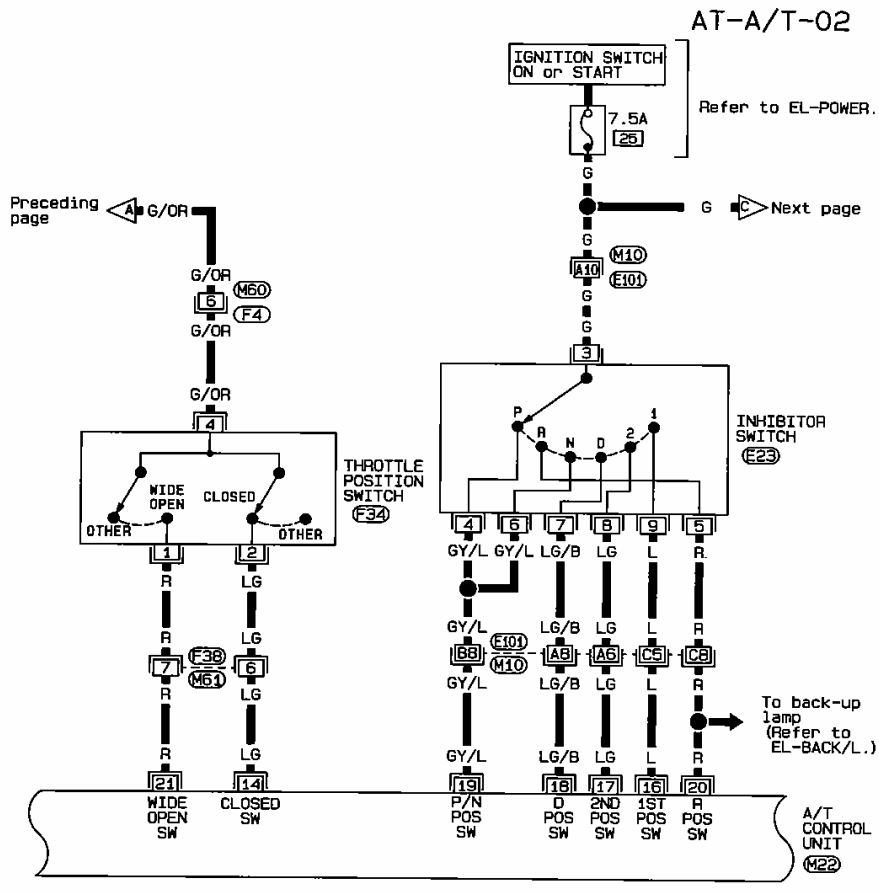

Refer to last page (Foldout page).

- M10, E101
- M50, F4



TROUBLE DIAGNOSES

Wiring Diagram — AT — (Cont'd)

AT-A/T-03

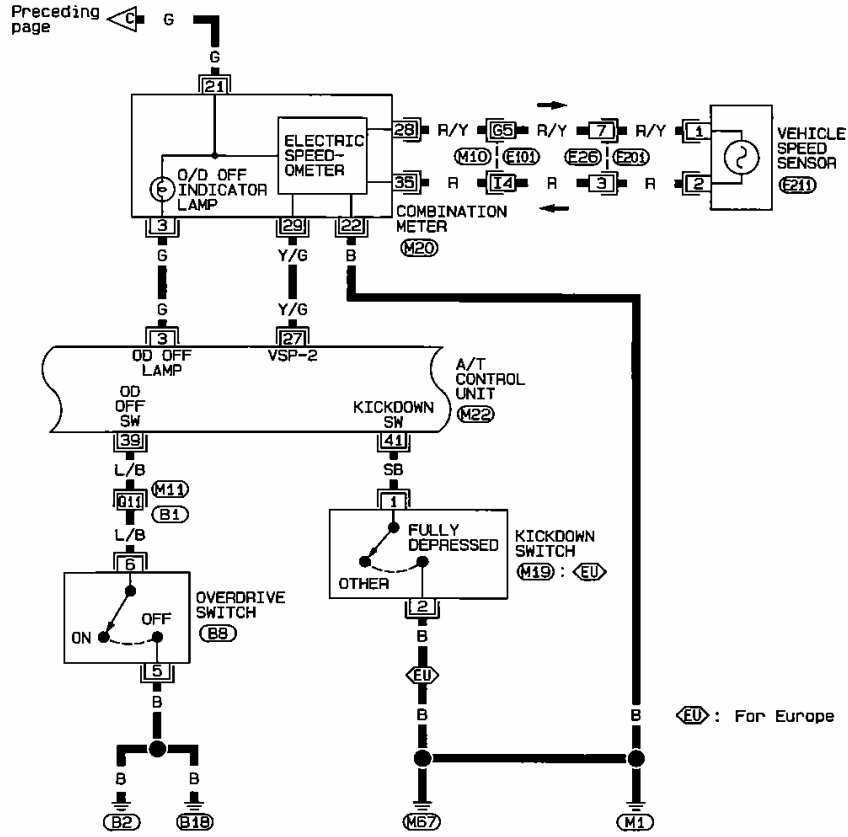

AT

EU: For Europe

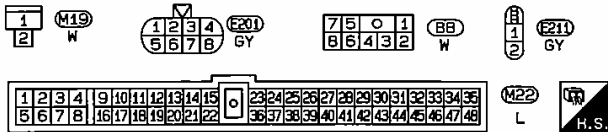
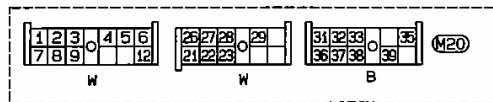

Refer to last page (Foldout page).

M10, E101
M11, B1

HAT015

TROUBLE DIAGNOSES

Wiring Diagram — AT — (Cont'd)

AT-A/T-04

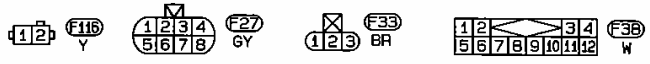
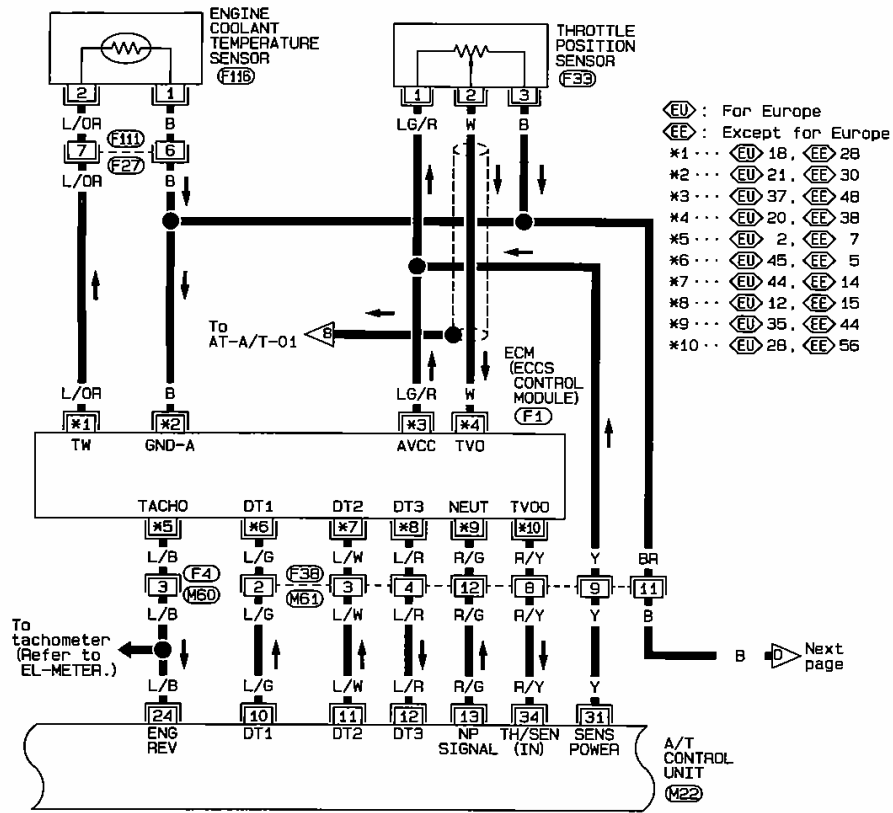

Refer to last page (Foldout page).

- M60, F4
- F1

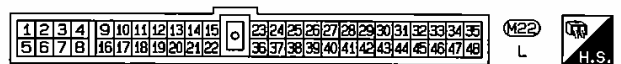

TROUBLE DIAGNOSES

Wiring Diagram — AT — (Cont'd)

AT-A/T-05

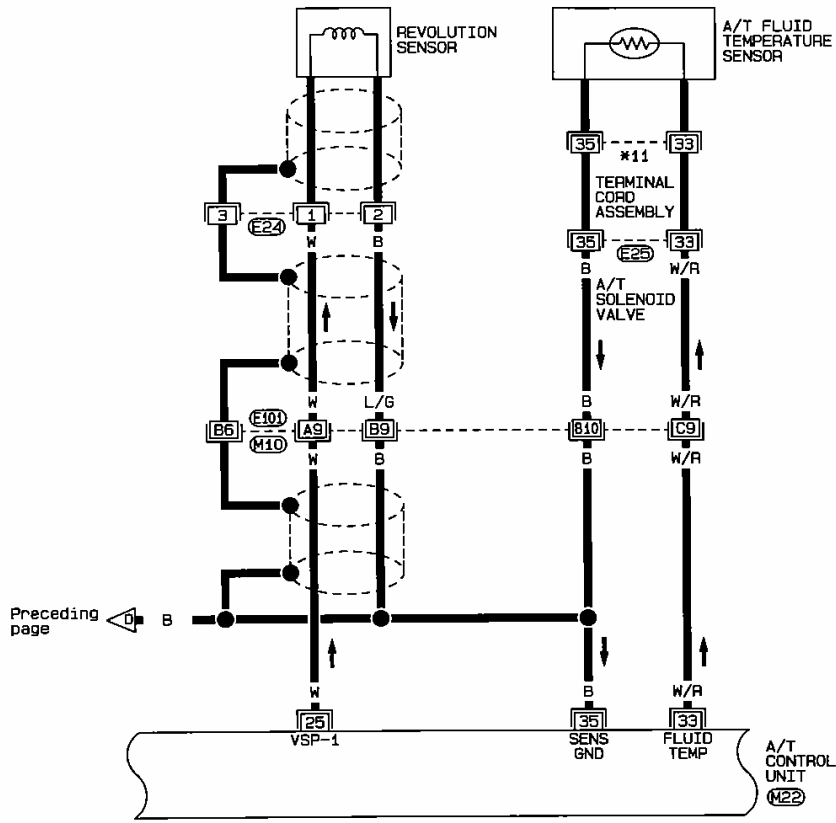

AT



Refer to last page (Foldout page).

(M10), (E10)

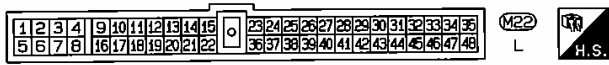

TROUBLE DIAGNOSES

Wiring Diagram — AT — (Cont'd)

AT-A/T-06

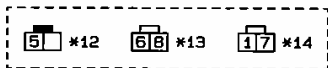
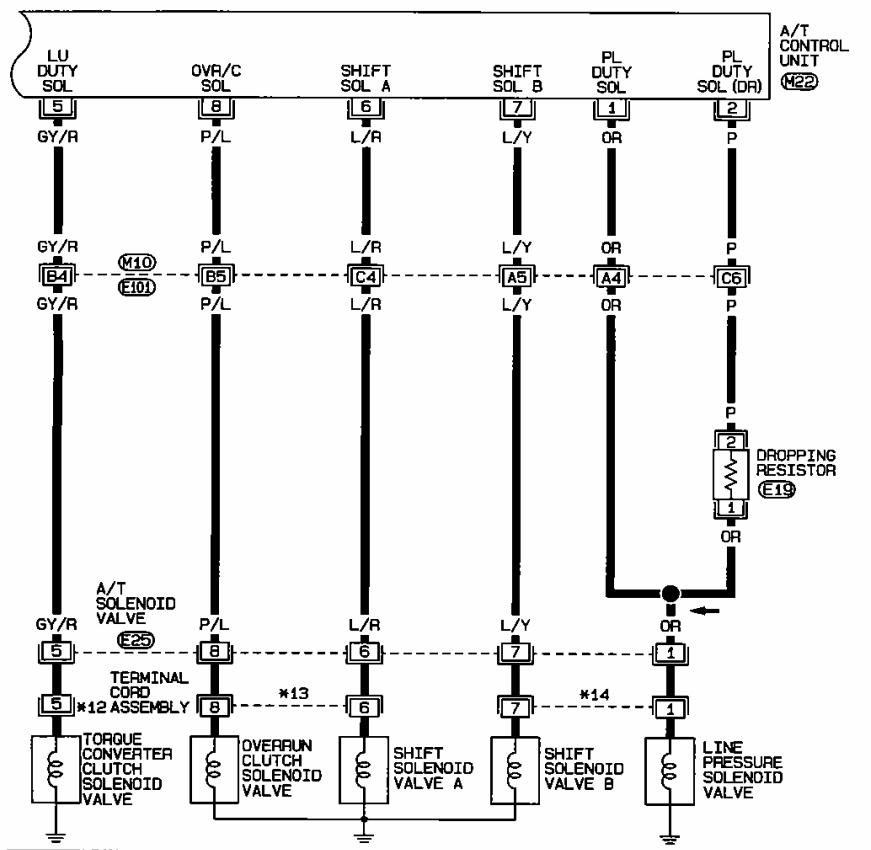

Refer to last page (Foldout page).

(M10), (E10)



M22

L



HAT018

TROUBLE DIAGNOSES

Wiring Diagram — AT — (Cont'd)

RHD MODELS

AT-A/T-07

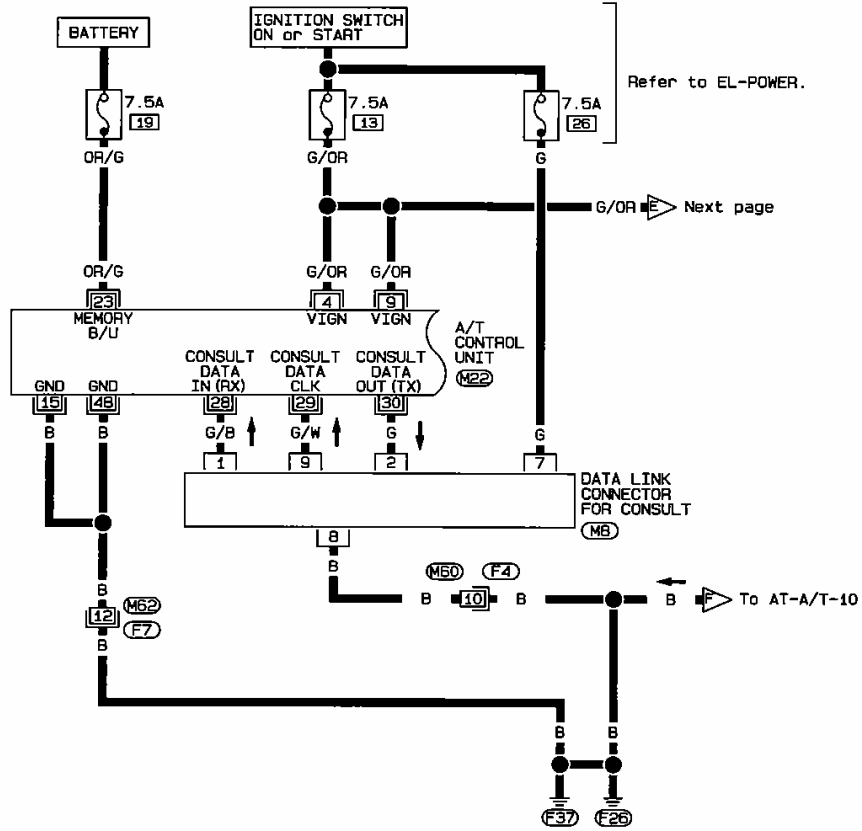

Refer to EL-POWER.

Next page

AT

Refer to last page
(Foldout page).

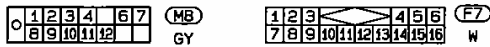

(M60), (F4)

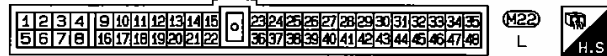

TROUBLE DIAGNOSES

Wiring Diagram — AT — (Cont'd)

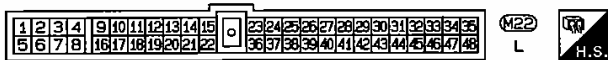
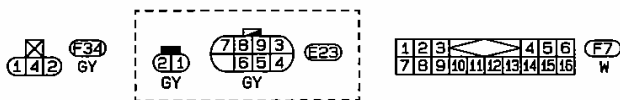
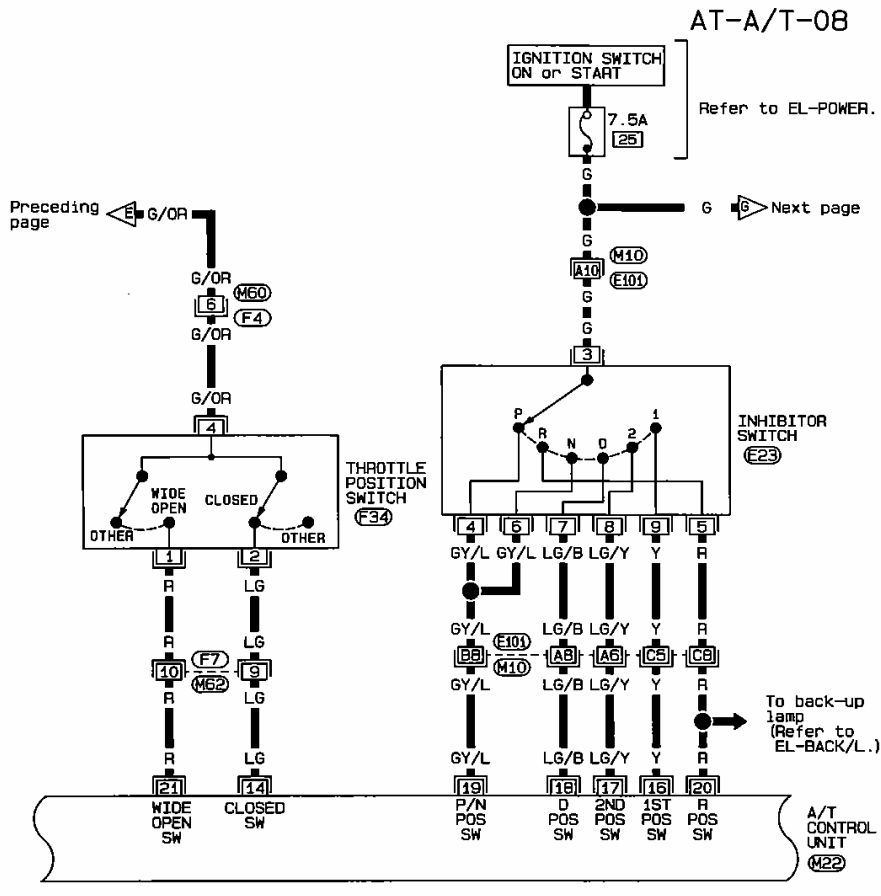

Refer to last page (Foldout page).

M10, E101
M60, F4

HAT020

TROUBLE DIAGNOSES

Wiring Diagram — AT — (Cont'd)

AT-A/T-09

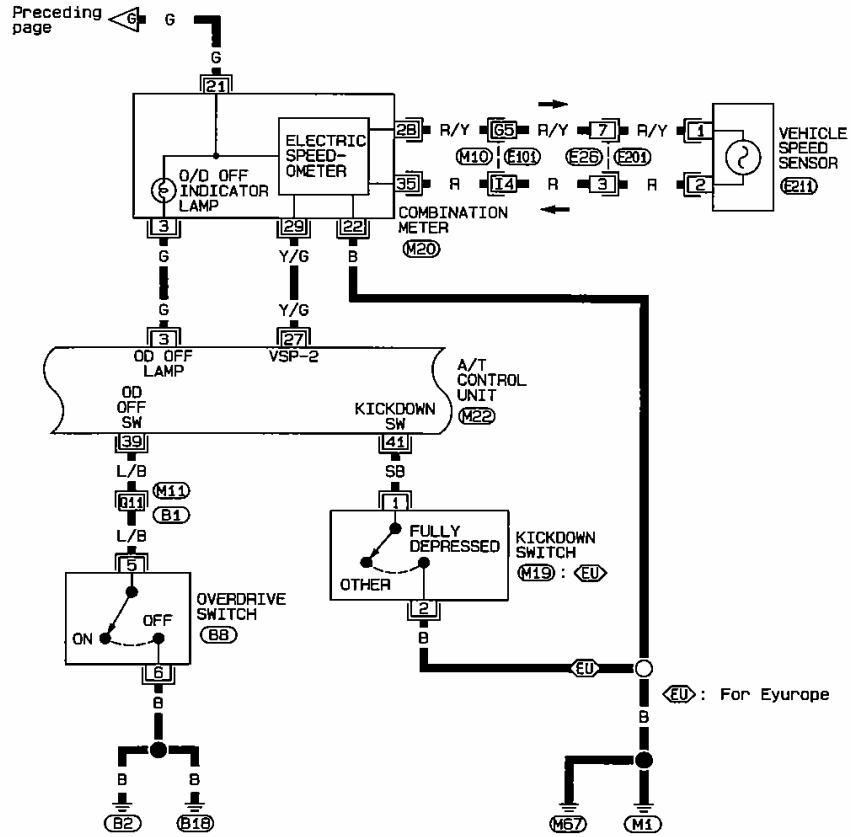

AT

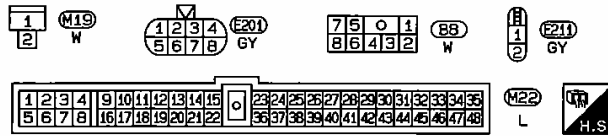
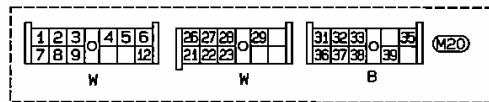

Refer to last page (Foldout page).

M10, E101
M11, B1

HAT021

TROUBLE DIAGNOSES

Wiring Diagram — AT — (Cont'd)

AT-A/T-10

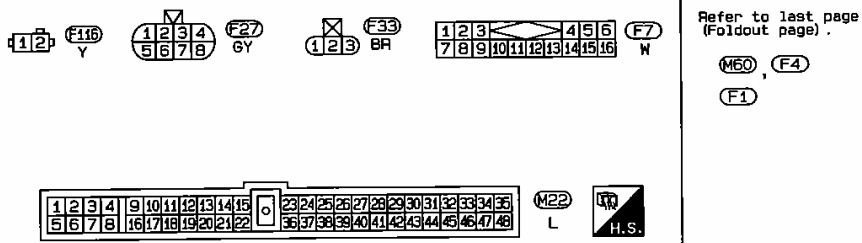
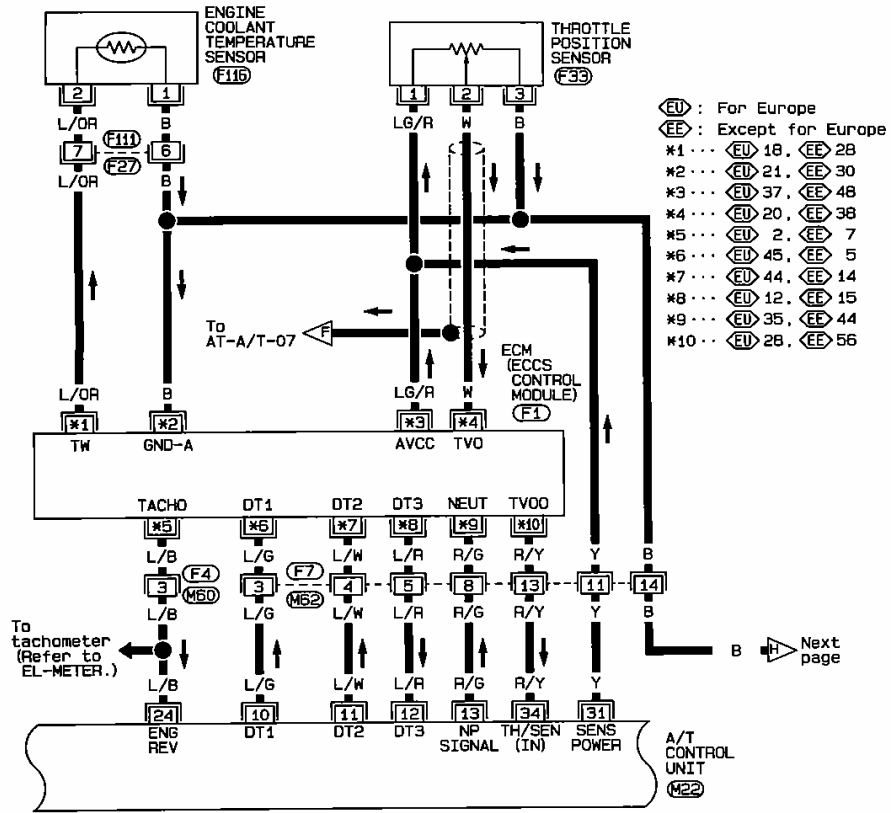

TROUBLE DIAGNOSES

Wiring Diagram — AT — (Cont'd)

AT-A/T-11

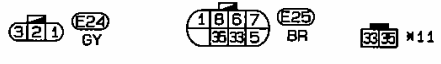
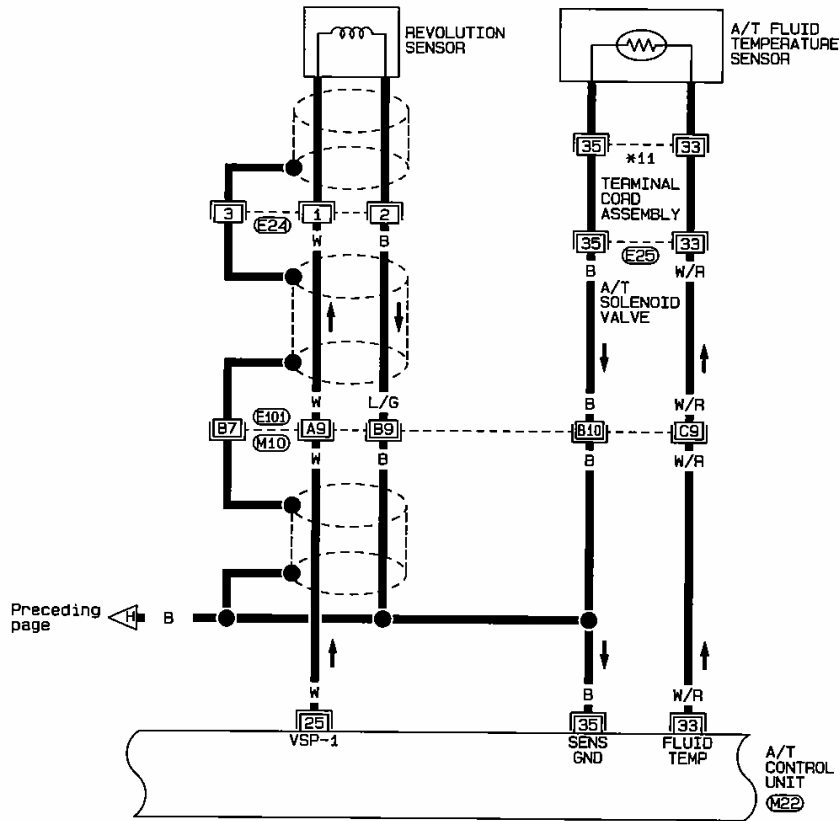

Refer to last page (Foldout page).

M10, E10

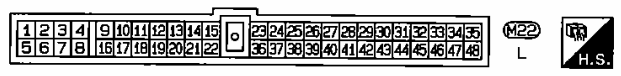

TROUBLE DIAGNOSES

Wiring Diagram — AT — (Cont'd)

AT-A/T-12

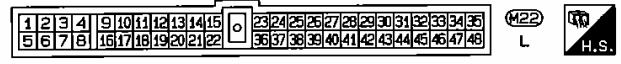
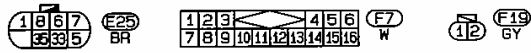
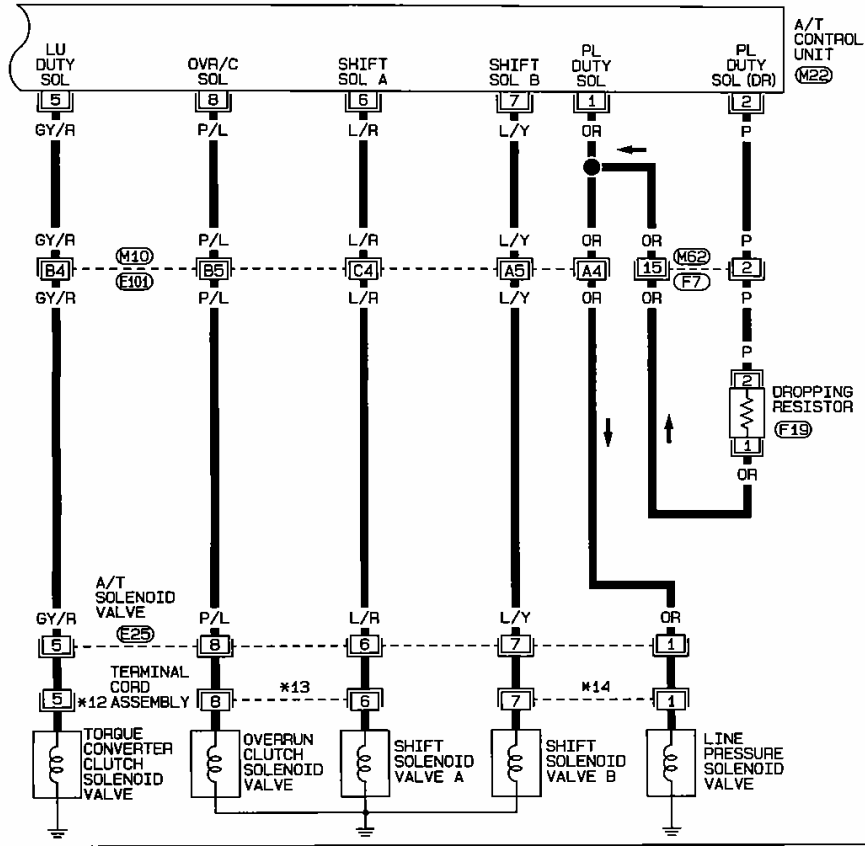

Refer to last page (Foldout page).
M10, F10

HAT024

SERVICE DATA AND SPECIFICATIONS (SDS)

General Specifications

Engine	SR20DET
Automatic transmission model	RE4R01A
Transmission model code number	42X65
Stall torque ratio	2.3 : 1
Transmission gear ratio	
1st	2.785
2nd	1.545
Top	1.000
OD	0.694
Reverse	2.272
Recommended oil	Genuine Nissan ATF or equivalent
Oil capacity (Imp qt)	7.9 (7)

Specifications and Adjustment

VEHICLE SPEED WHEN SHIFTING GEARS

Throttle position	Vehicle speed km/h (MPH)						
	D ₁ → D ₂	D ₂ → D ₃	D ₃ → D ₄	D ₄ → D ₅	D ₅ → D ₇	D ₂ → D ₁	1 ₂ → 1 ₁
Full throttle	64 - 68 (40 - 42)	114 - 122 (71 - 76)	182 - 192 (113 - 119)	176 - 186 (109 - 116)	103 - 111 (64 - 69)	40 - 44 (25 - 27)	46 - 50 (29 - 31)
Half throttle	51 - 55 (32 - 34)	93 - 99 (58 - 62)	146 - 154 (91 - 96)	87 - 95 (54 - 59)	39 - 45 (24 - 28)	10 - 14 (6 - 9)	46 - 50 (29 - 31)

AT

VEHICLE SPEED WHEN PERFORMING AND RELEASING LOCK-UP

Throttle position	OD switch [Shift position]	Vehicle speed km/h (MPH)	
		Lock-up "ON"	Lock-up "OFF"
Full throttle	ON [D ₄]	183 - 191 (114 - 119)	177 - 185 (110 - 115)
	OFF [D ₃]	91 - 99 (57 - 62)	86 - 94 (53 - 58)
Half throttle	ON [D ₄]	146 - 154 (91 - 96)	122 - 130 (76 - 81)
	OFF [D ₃]	92 - 100 (57 - 62)	86 - 94 (53 - 58)

STALL REVOLUTION

Stall revolution rpm
2,725 - 2,975

LINE PRESSURE

Engine speed rpm	Line pressure kPa (bar, kg/cm ² , psi)	
	D, 2 and 1 positions	R position
Idle	432 - 471 (4.320 - 4.710, 4.41 - 4.80, 62.6 - 68.3)	676.7 - 715.0 (6.767 - 7.150, 6.90 - 7.29, 98.1 - 103.7)
Stall	1,039 - 1,118 (10.390 - 11.180, 10.60 - 11.40, 150.7 - 162.1)	1,480 - 1,558 (14.800 - 15.580, 15.10 - 15.89, 214.6 - 225.9)

SERVICE DATA AND SPECIFICATIONS (SDS)

Specifications and Adjustment (Cont'd)

RETURN SPRINGS

Unit: mm (in)

Parts		Part No.	Free length	Outer diameter		
Control valve	Upper body	① Torque converter relief valve spring	31742-41X23	38.0 (1.496)	9.0 (0.354)	
		② Pressure regulator valve spring	31742-41X24	44.0 (1.732)	14.0 (0.551)	
		③ Pressure modifier valve spring	31742-41X19	31.95 (1.2579)	6.8 (0.268)	
		④ Shuttle shift valve D spring	31762-41X00	26.5 (1.043)	6.0 (0.236)	
		⑤ 4-2 sequence valve spring	31756-41X00	29.1 (1.146)	6.95 (0.2736)	
		⑥ Shift valve B spring	31762-41X01	25.0 (0.984)	7.0 (0.276)	
		⑦ 4-2 relay valve spring	31756-41X00	29.1 (1.146)	6.95 (0.2736)	
		⑧ Shift valve A spring	31762-41X01	25.0 (0.984)	7.0 (0.276)	
		⑨ Overrun clutch control valve spring	31762-41X03	23.6 (0.929)	7.0 (0.276)	
		⑩ Overrun clutch reducing valve spring	31742-41X20	32.5 (1.280)	7.0 (0.276)	
		⑪ Shuttle shift valve S spring	31762-41X04	51.0 (2.008)	5.65 (0.2224)	
		⑫ Pilot valve spring	31742-41X13	25.7 (1.012)	9.1 (0.358)	
		⑬ Lock-up control valve spring	31742-41X22	18.5 (0.728)	13.0 (0.512)	
		Lower body	① Modifier accumulator piston spring	31742-27X70	31.4 (1.236)	9.8 (0.386)
			② 1st reducing valve spring	31756-41X05	25.4 (1.000)	6.75 (0.2657)
			③ 3-2 timing valve spring	31742-41X06	23.0 (0.906)	6.7 (0.264)
④ Servo charger valve spring	31742-41X06		23.0 (0.906)	6.7 (0.264)		
Reverse clutch	16 pcs	31505-41X02	19.69 (0.7752)	11.6 (0.457)		
High clutch	16 pcs	31505-21X03	22.1 (0.870)	11.6 (0.457)		
Forward clutch (Overrun clutch)	20 pcs	31521-41X00 (Assembly)	35.77 (1.4083)	9.7 (0.382)		
Low & reverse brake	18 pcs	31505-41X05	22.3 (0.878)	11.6 (0.457)		
Band servo	Spring A	31605-41X05	45.6 (1.795)	34.3 (1.350)		
	Spring B	31605-41X00	53.8 (2.118)	40.3 (1.587)		
	Spring C	31605-41X01	29.7 (1.169)	27.6 (1.087)		
Accumulator	Accumulator A	31605-41X02	43.0 (1.693)	—		
	Accumulator B	31605-41X10	66.0 (2.598)	—		
	Accumulator C	31605-41X09	45.0 (1.772)	—		
	Accumulator D	31605-41X06	58.4 (2.299)	—		

SERVICE DATA AND SPECIFICATIONS (SDS)

Specifications and Adjustment (Cont'd)

ACCUMULATOR O-RING

Accumulator	Diameter mm (in)			
	A	B	C	D
Small diameter end	29 (1.14)	32 (1.26)	45 (1.77)	29 (1.14)
Large diameter end	45 (1.77)	50 (1.97)	50 (1.97)	45 (1.77)

CLUTCHES AND BRAKES

Reverse clutch		
Number of drive plates	2	
Number of driven plates	2	
Thickness of drive plate mm (in)		
Standard	2.0 (0.079)	
Wear limit	1.8 (0.071)	
Clearance mm (in)		
Standard	0.5 - 0.8 (0.020 - 0.031)	
Allowable limit	1.2 (0.047)	
Thickness of retaining plate	Thickness mm (in)	Part number
	4.8 (0.189)	31537-42X02
	5.0 (0.197)	31537-42X03
	5.2 (0.205)	31537-42X04
	5.4 (0.213)	31537-42X05
5.6 (0.220)	31537-42X06	
High clutch		
Number of drive plates	5	
Number of driven plates	5	
Thickness of drive plate mm (in)		
Standard	1.6 (0.063)	
Wear limit	1.4 (0.055)	
Clearance mm (in)		
Standard	1.8 - 2.2 (0.071 - 0.087)	
Allowable limit	3.0 (0.118)	
Thickness of retaining plate	Thickness mm (in)	Part number
	3.4 (0.134)	31537-41X71
	3.6 (0.142)	31537-41X61
	3.8 (0.150)	31537-41X62
	4.0 (0.157)	31537-41X63
	4.2 (0.165)	31537-41X64
	4.4 (0.173)	31537-41X65
	4.6 (0.181)	31537-41X66
4.8 (0.189)	31537-41X67	

Forward clutch		
Number of drive plates	7	
Number of driven plates	7	
Thickness of drive plate mm (in)		
Standard	1.6 (0.063)	
Wear limit	1.4 (0.055)	
Clearance mm (in)		
Standard	0.45 - 0.85 (0.0177 - 0.0335)	
Allowable limit	1.85 (0.0728)	
Thickness of retaining plate	Thickness mm (in)	Part number
	4.6 (0.181)	31537-42X13
	4.8 (0.189)	31537-42X14
	5.0 (0.197)	31537-42X15
	5.2 (0.205)	31537-42X16
	5.4 (0.213)	31537-42X17
5.6 (0.220)	31537-42X18	
Overrun clutch		
Number of drive plates	3	
Number of driven plates	5	
Thickness of drive plate mm (in)		
Standard	2.0 (0.079)	
Wear limit	1.8 (0.071)	
Clearance mm (in)		
Standard	1.0 - 1.4 (0.039 - 0.055)	
Allowable limit	2.0 (0.079)	
Thickness of retaining plate	Thickness mm (in)	Part number
	4.2 (0.165)	31537-41X80
	4.4 (0.173)	31537-41X81
	4.6 (0.181)	31537-41X82
	4.8 (0.189)	31537-41X83
5.0 (0.197)	31537-41X84	

AT

SERVICE DATA AND SPECIFICATIONS (SDS)

Specifications and Adjustment (Cont'd)

Low & reverse brake		
Number of drive plates	8	
Number of driven plates	8	
Thickness of drive plate mm (in)		
Standard	2.0 (0.079)	
Wear limit	1.8 (0.071)	
Clearance mm (in)		
Standard	0.7 - 1.1 (0.028 - 0.043)	
Allowable limit	2.3 (0.091)	
Thickness of retaining plate	Thickness mm (in)	Part number
	6.2 (0.244)	31667-41X15
	6.4 (0.252)	31667-41X16
	6.6 (0.260)	31667-41X17
	6.8 (0.268)	31667-41X11
	7.0 (0.276)	31667-41X12
	7.2 (0.283)	31667-41X13
Brake band		
Anchor end bolt tightening torque N·m (kg-m, In-lb)	4 - 6 (0.4 - 0.6, 35 - 52)	
Number of returning revolutions for anchor end bolt	2.5	

OIL PUMP AND LOW ONE-WAY CLUTCH

Oil pump clearance mm (in)	
Cam ring — oil pump housing	
Standard	0.01 - 0.024 (0.0004 - 0.0009)
Rotor, vanes and control piston — oil pump housing	
Standard	0.03 - 0.044 (0.0012 - 0.0017)
Seal ring clearance mm (in)	
Standard	0.10 - 0.25 (0.0039 - 0.0098)
Allowable limit	0.25 (0.0098)

TOTAL END PLAY

Total end play "T ₁ "	0.25 - 0.55 mm (0.0098 - 0.0217 in)	
Thickness of oil pump cover bearing race	Thickness mm (in)	Part number
	0.8 (0.031)	31435-41X01
	1.0 (0.039)	31435-41X02
	1.2 (0.047)	31435-41X03
	1.4 (0.055)	31435-41X04
	1.6 (0.063)	31435-41X05
	1.8 (0.071)	31435-41X06
2.0 (0.079)	31435-41X07	

REVERSE CLUTCH DRUM END PLAY

Reverse clutch drum end play "T ₂ "	0.55 - 0.90 mm (0.0217 - 0.0354 in)	
Thickness of oil pump thrust washer	Thickness mm (in)	Part number
	0.9 (0.035)	31528-21X01
	1.1 (0.043)	31528-21X02
	1.3 (0.051)	31528-21X03
	1.5 (0.059)	31528-21X04
	1.7 (0.067)	31528-21X05
	1.9 (0.075)	31528-21X06

REMOVAL AND INSTALLATION

Manual control linkage	
Number of returning revolutions for lock nut	1
Lock nut tightening torque	11 - 15 N·m (1.1 - 1.5 kg-m, 8 - 11 ft-lb)
Distance between end of clutch housing and torque converter	23.5 mm (0.925 in) or more

FRONT AXLE & FRONT SUSPENSION

SECTION **FA**

MODIFICATION NOTICE:

- The service data and specifications (SDS) have been changed.

CONTENTS

FRONT SUSPENSION	2	SERVICE DATA AND SPECIFICATIONS (SDS).....	3
		Inspection and Adjustment.....	3

FA

FRONT SUSPENSION

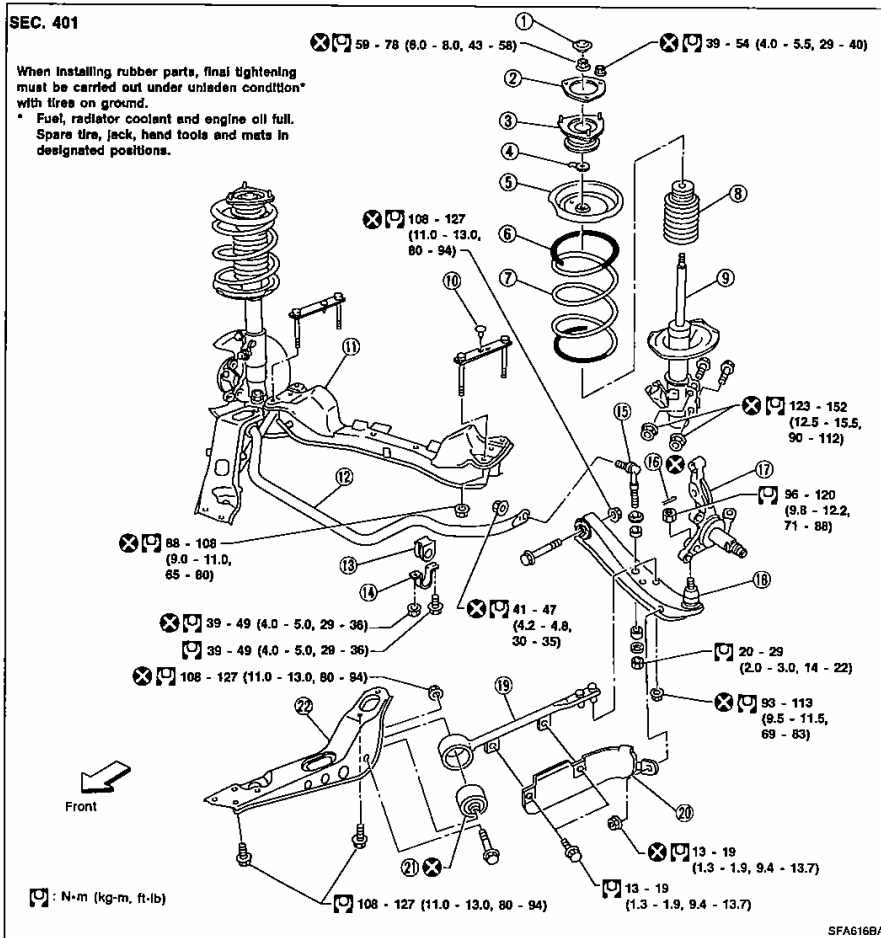

- | | | |
|----------------------------|-----------------------------|-----------------------------------|
| ① Cap | ⑨ Strut assembly | ⑮ Cotter pin |
| ② Gasket | ⑩ Plastic clip | ⑯ Knuckle spindle |
| ③ Strut mounting insulator | ⑪ Front suspension member | ⑰ Transverse link with ball joint |
| ④ Lock washer | ⑫ Stabilizer | ⑱ Tension rod |
| ⑤ Upper seat | ⑬ Bushing | ⑳ Air guide |
| ⑥ (Polyurethane tube) | ⑭ Clamp | ㉑ Tension rod bushing |
| ⑦ Coil spring | ⑮ Stabilizer connecting rod | ㉒ Tension rod bracket |
| ⑧ Bound bumper | | |

SERVICE DATA AND SPECIFICATIONS (SDS)

Inspection and Adjustment

LOWER BALL JOINT

Swinging force "A" (Measuring point: cotter pin hole of ball stud) N (kg, lb)	7.8 - 54.9 (0.8 - 5.6, 1.8 - 12.3)
Turning torque "B" N-m (kg-cm, in-lb)	0.5 - 3.4 (5 - 35, 4.3 - 30.4)
Vertical end play "C" mm (in)	0 (0)

FA

**REAR AXLE &
REAR SUSPENSION**

SECTION RA

MODIFICATION NOTICE:

- The service data and specifications (SDS) have been changed.

CONTENTS

SERVICE DATA AND SPECIFICATIONS (SDS)..... 2
General Specifications..... 2

RA

SERVICE DATA AND SPECIFICATIONS (SDS)

General Specifications

DRIVE SHAFT

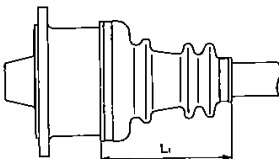
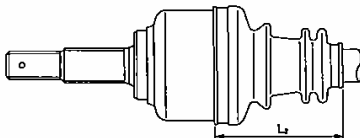
Joint type		Final drive side 
Final drive side	TS82F	
Wheel side	TS82C	Wheel side 
Grease name	Nissan genuine grease or equivalent	
Final drive side	Nissan genuine grease or equivalent	SRA133A
Wheel side	Nissan genuine grease or equivalent	
Specified amount of grease		SRA543A
g (oz)		
Final drive side	102 - 107 (3.60 - 3.77)	
Wheel side	115 - 125 (4.06 - 4.41)	
Bool length	mm (in)	
Final drive side (L ₁)	95 - 97 (3.74 - 3.82)	
Wheel side (L ₂)		

BRAKE SYSTEM

SECTION BR

MODIFICATION NOTICE:

- The anti-lock brake system wiring diagrams have been changed.
- The service data and specifications (SDS) have been changed.

CONTENTS

ANTI-LOCK BRAKE SYSTEM	2	SERVICE DATA AND SPECIFICATIONS (SDS)	12
Wiring Diagram — ABS —.....	2	General Specifications.....	12
		Inspection and Adjustment.....	12

BR

ANTI-LOCK BRAKE SYSTEM

Wiring Diagram — ABS —

LHD MODELS

BR-ABS-01

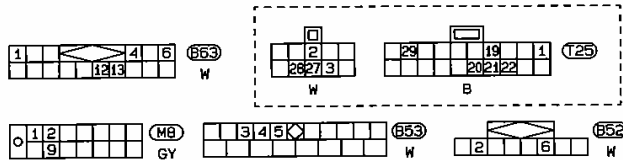
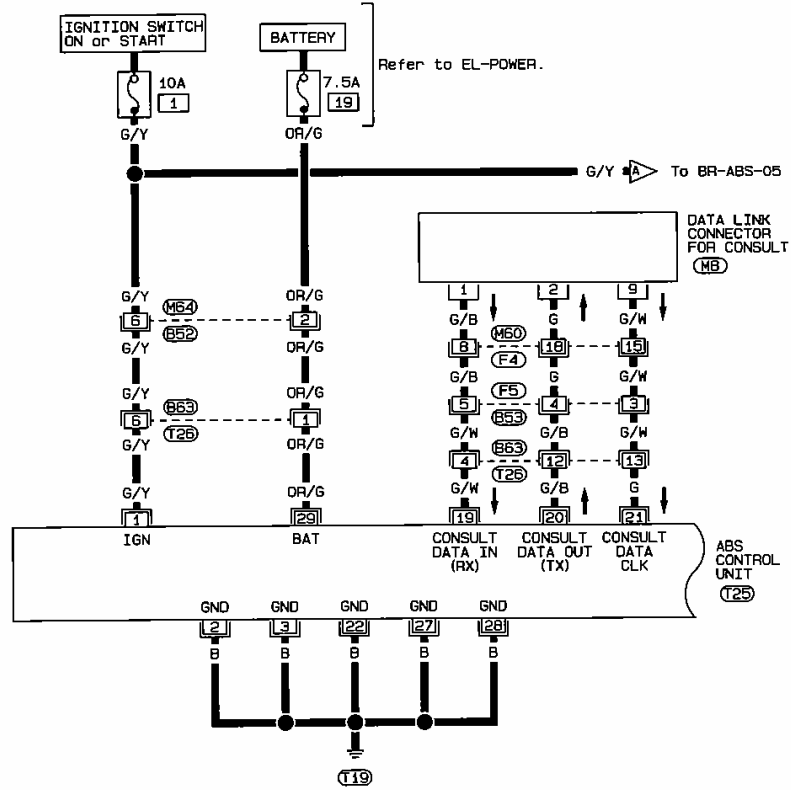

ANTI-LOCK BRAKE SYSTEM

Wiring Diagram — ABS — (Cont'd)

BR-ABS-02

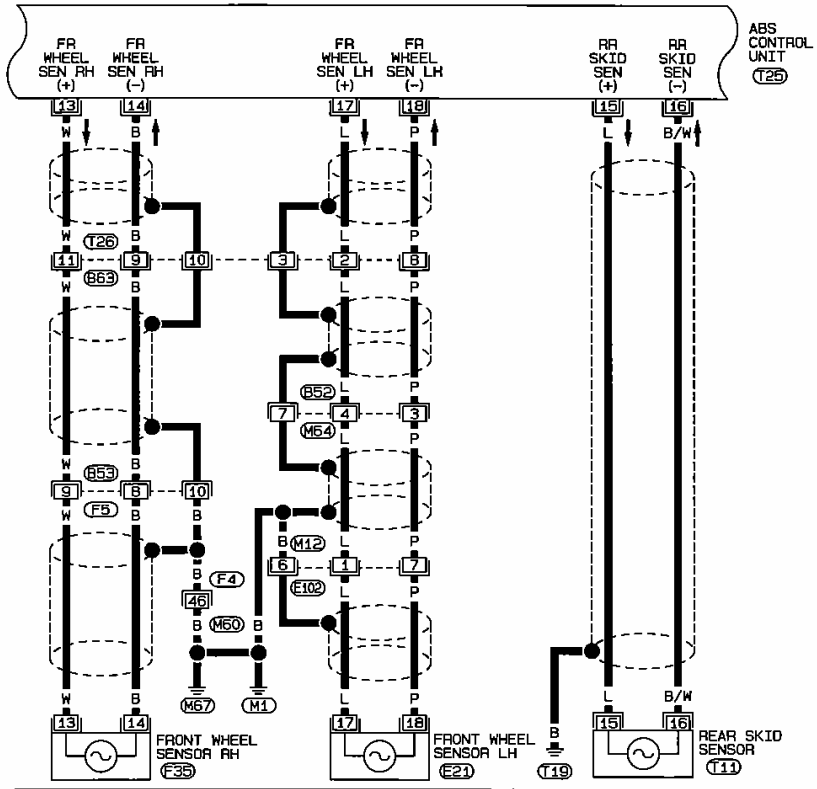

BR

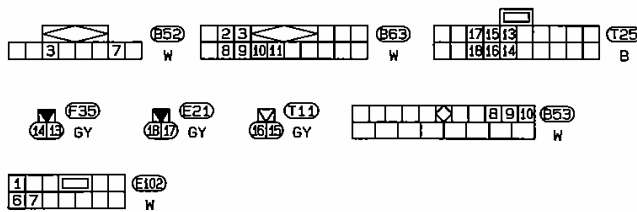

Refer to last page (Foldout page).

M50, F4

HBR015

ANTI-LOCK BRAKE SYSTEM

Wiring Diagram — ABS — (Cont'd)

BR-ABS-03

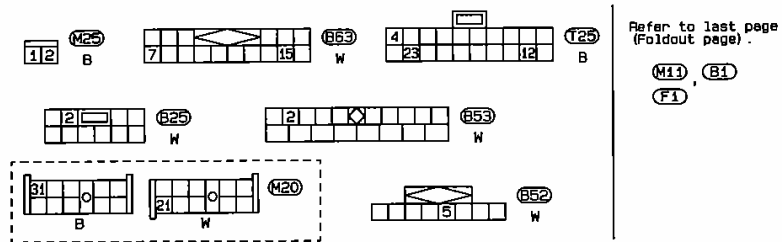
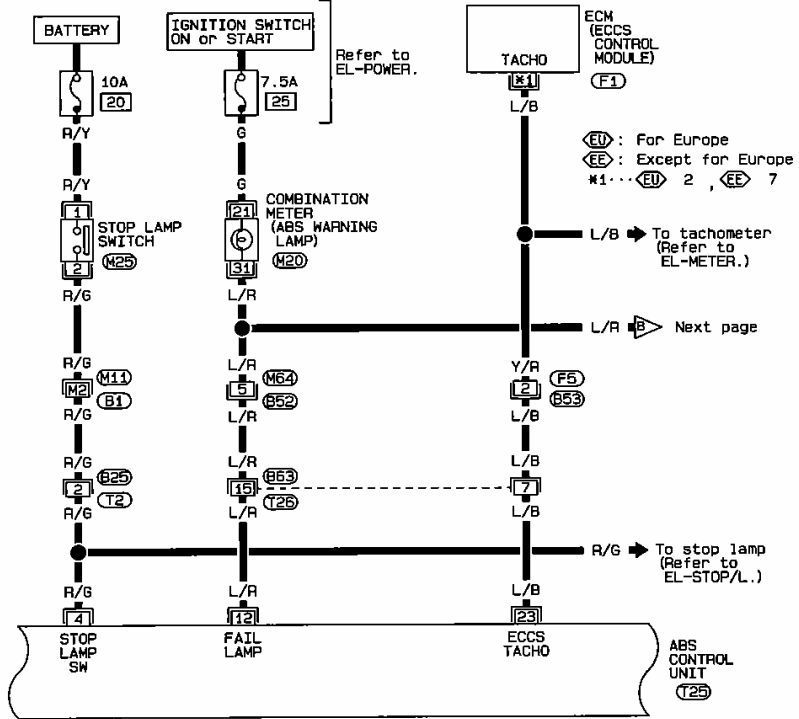

ANTI-LOCK BRAKE SYSTEM

Wiring Diagram — ABS — (Cont'd)

BR-ABS-04

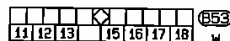
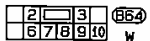
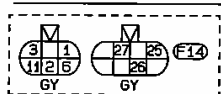
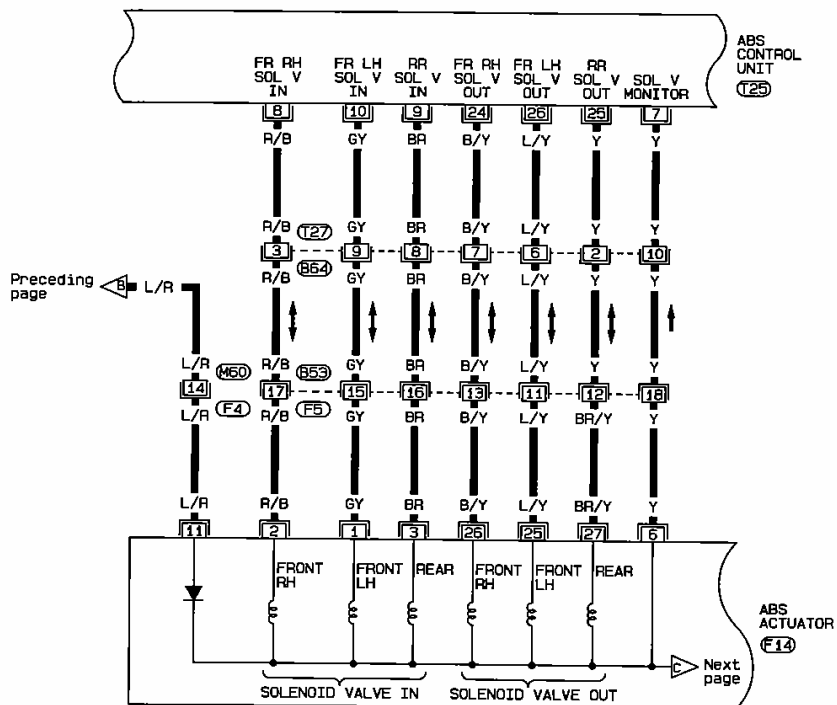

Refer to last page (Foldout page).

M60, F4

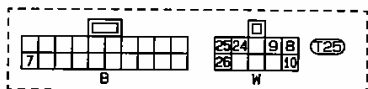

BR

ANTI-LOCK BRAKE SYSTEM

Wiring Diagram — ABS — (Cont'd)

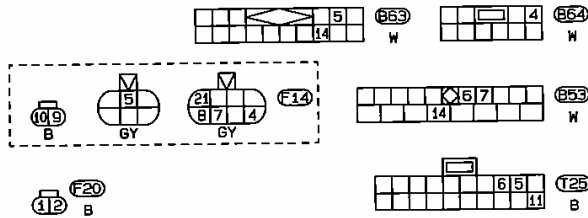
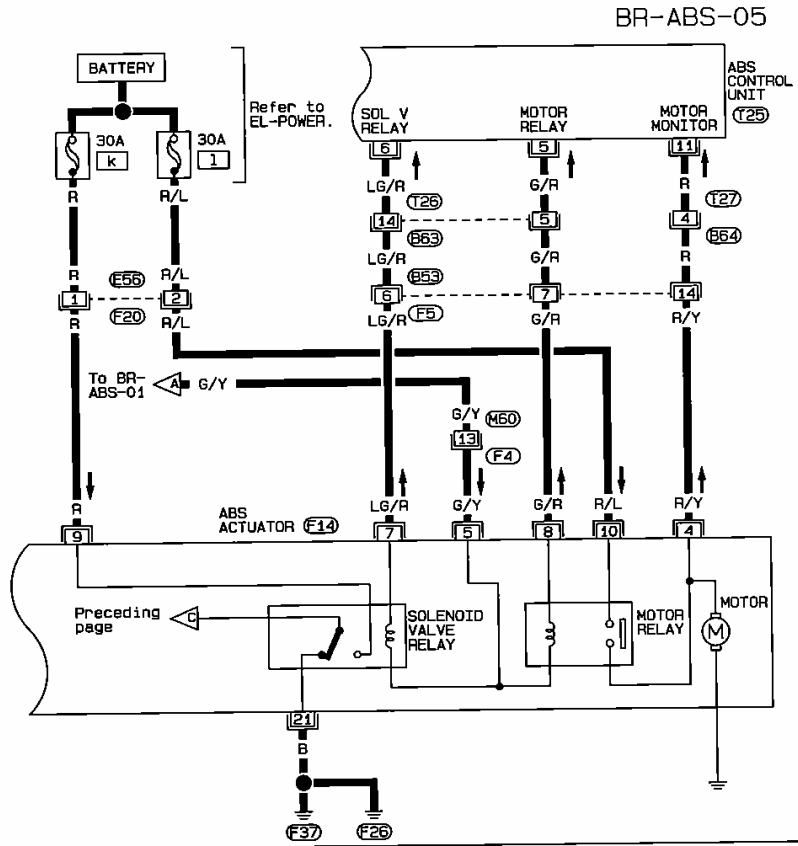

Refer to last page
(Foldout page).

M60, F4

SBR005D

ANTI-LOCK BRAKE SYSTEM

Wiring Diagram — ABS — (Cont'd)

RHD MODELS

BR-ABS-06

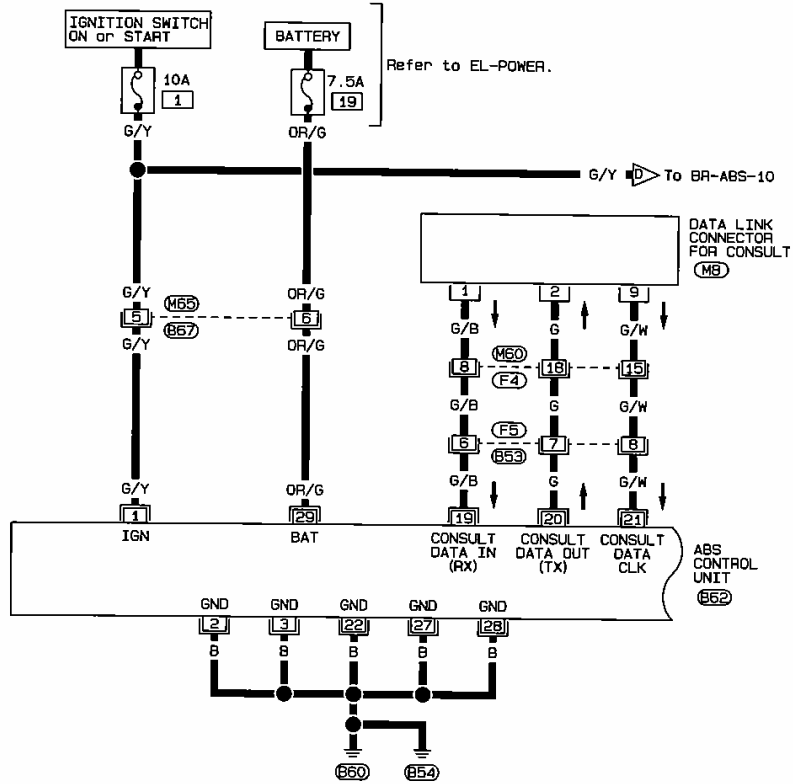

BR

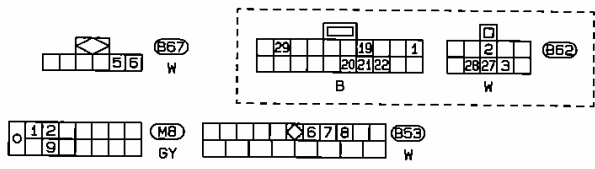

Refer to last page (Foldout page).
 (M50), (F4)

ANTI-LOCK BRAKE SYSTEM

Wiring Diagram — ABS — (Cont'd)

BR-ABS-07

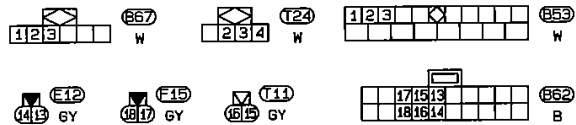
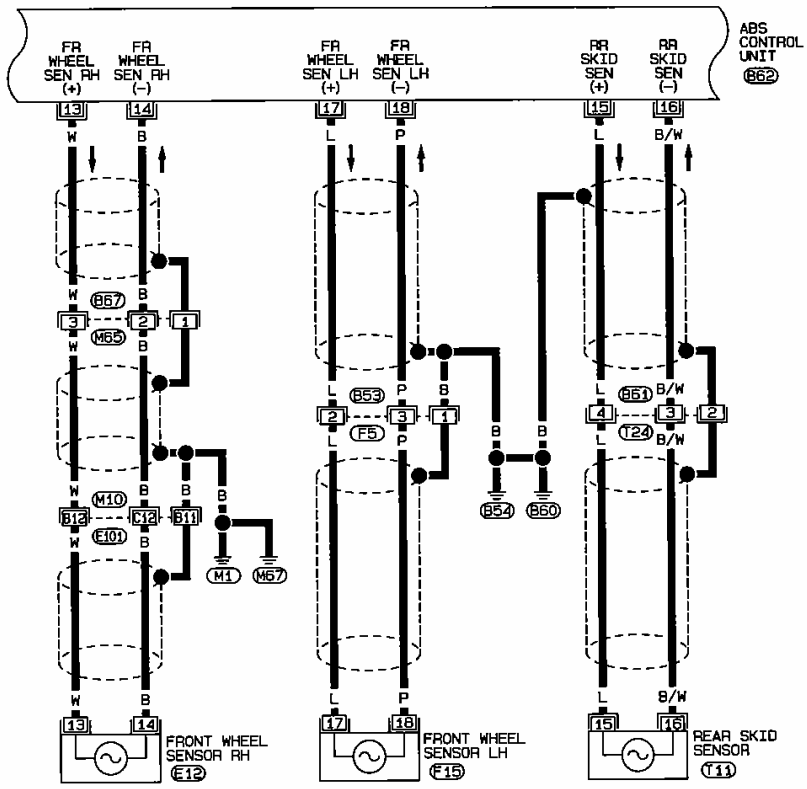

Refer to last page (Foldout page).

M10, E101

HBR010

ANTI-LOCK BRAKE SYSTEM

Wiring Diagram — ABS — (Cont'd)

BR-ABS-08

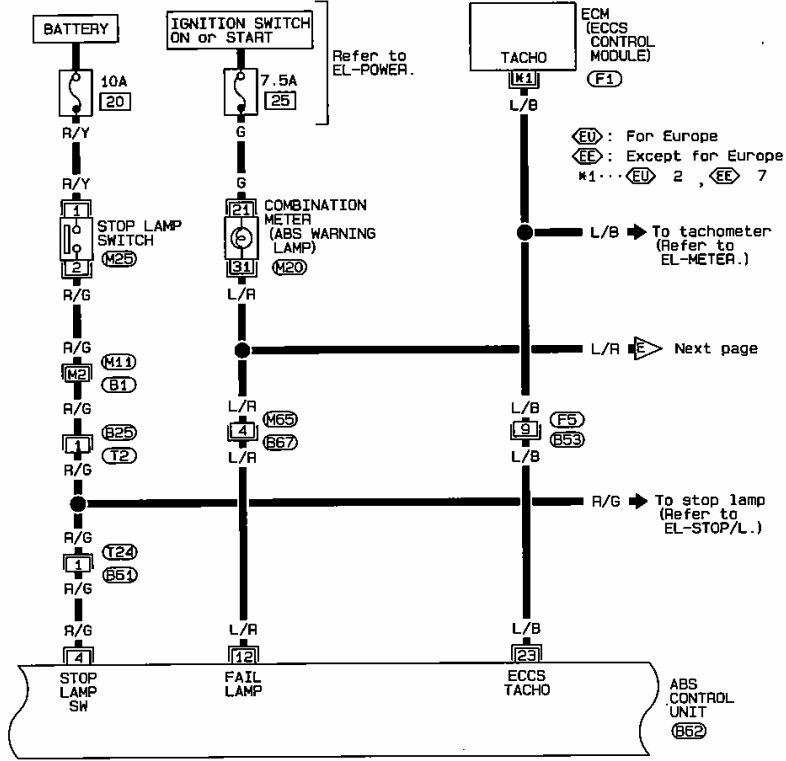

BR

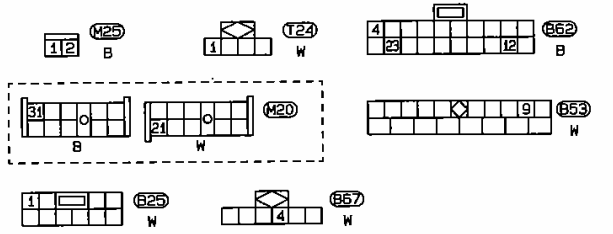

Refer to last page (Foldout page).

M11, B1
 F1

ANTI-LOCK BRAKE SYSTEM

Wiring Diagram — ABS — (Cont'd)

BR-ABS-09

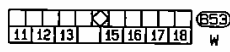
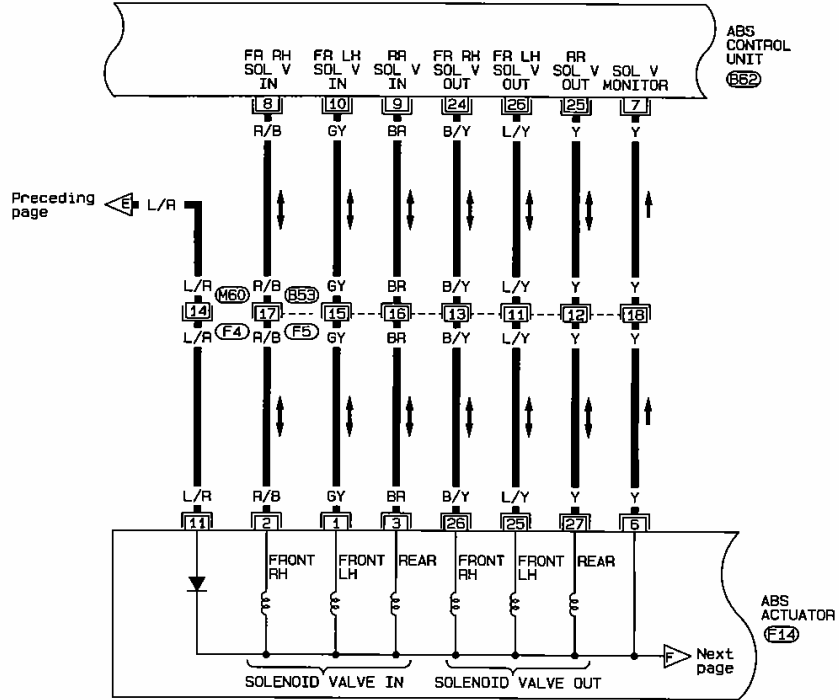

Refer to last page (Foldout page).

(M60), (F4)

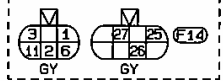

ANTI-LOCK BRAKE SYSTEM

Wiring Diagram — ABS — (Cont'd)

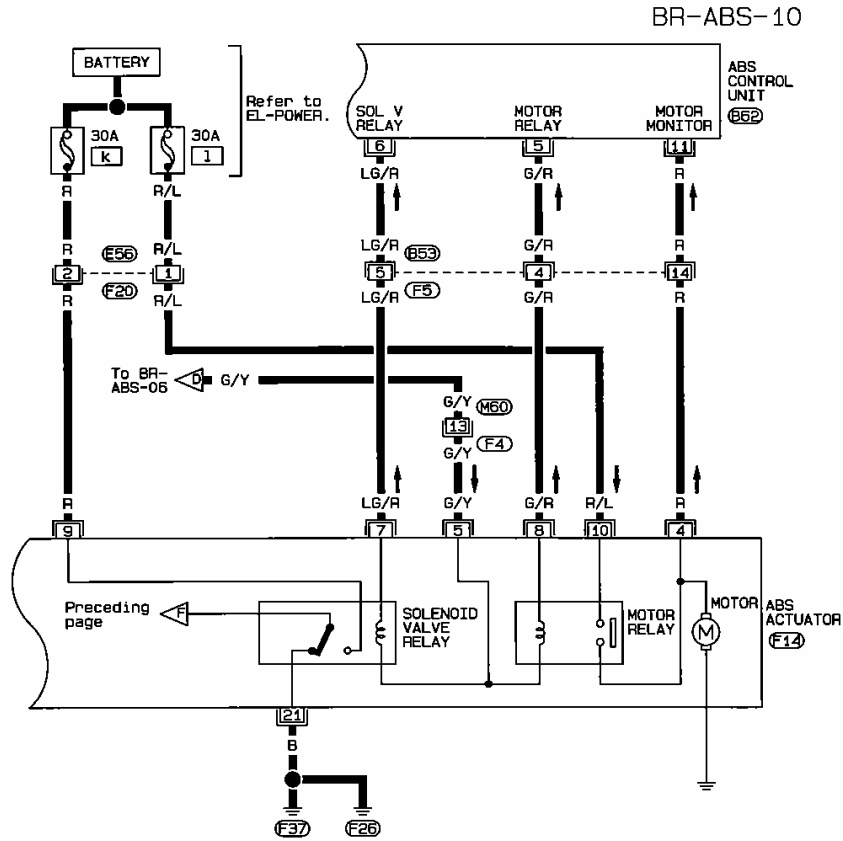

BR

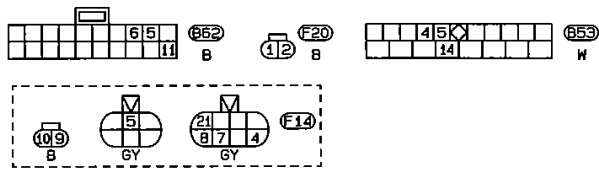

Refer to last page
(Foldout page).
M60, F4

SERVICE DATA AND SPECIFICATIONS (SDS)

General Specifications

Front brake	
Brake model	OPF25VA disc brake
Cylinder bore diameter mm (in)	40.4 (1.59) x 2
Pad mm (in) Length x width x thickness	116.0 x 50.0 x 10.0 (4.57 x 1.969 x 0.394)
Rotor outer diameter x thickness mm (in)	280 x 30 (11.02 x 1.18)
Rear brake	
Brake model	CL11H disc brake
Cylinder bore diameter mm (in)	38.18 (1.5031)
Pad mm (in) Length x width x thickness	75.0 x 40.0 x 9.5 (2.953 x 1.575 x 0.374)
Rotor outer diameter x thickness mm (in)	258 x 9 (10.16 x 0.35)

	Without ABS	With ABS
Master cylinder		
Cylinder bore diameter mm (in)	23.81 (15/16)	25.40 (1)
Control valve		
Valve model	Proportioning valve (built into master cylinder)	
Split point kPa (bar, kg/cm ² , psi) x reducing ratio	3,923 (39.2, 40, 569) x 0.4	
Brake booster		
Booster model	M23 or G23	M195T
Diaphragm diameter mm (in)	230 (9.06)	Primary: 205 (8.07) Secondary: 180 (7.09)
Recommended brake fluid		
For Europe*	DOT3 or DOT4	
Except for Europe	DOT 3	

*For Europe, never mix different type brake fluids (DOT3 and DOT4).

Inspection and Adjustment

DISC BRAKE

Brake model	OPF25VA	CL11H
Pad wear limit mm (in)	2.0 (0.079)	
Minimum thickness	2.0 (0.079)	
Rotor repair limit mm (in)	2.0 (0.079)	
Minimum thickness	28 (1.10)	8 (0.31)

BRAKE PEDAL

Vehicle model	LHD	RHD
Free height "H" mm (in)		
M/T	181 - 191 (7.13 - 7.52)	179 - 189 (7.05 - 7.44)
A/T	191 - 201 (7.52 - 7.91)	189 - 199 (7.44 - 7.83)
Depressed height "D" mm (in) [under force of 490 N (50 kg, 110 lb) with engine running]		
M/T	120 (4.72) 130 (5.12)*	
A/T	130 (5.12) 135 (5.31)*	
Clearance "C" between pedal stopper and threaded end of stop lamp switch or ASCD switch mm (in)	0.3 - 1.0 (0.012 - 0.039)	

*Without ABS for Australia

PARKING BRAKE

Type	Center lever
Number of notches [under force of 195 N (20 kg, 44 lb)]	7 - 9
Number of notches when warning lamp switch comes on	1

RESTRAINT SYSTEM

SECTION **RS**

MODIFICATION NOTICE:

Wiring diagrams have been changed.

CONTENTS

PRECAUTION	2	TROUBLE DIAGNOSES — Supplemental	
Supplemental Restraint System (SRS) "AIR		Restraint System (SRS)	3
BAG" and "SEAT BELT PRE-TENSIONER".....	2	Wiring Diagram — SRS —.....	3

RS

PRECAUTION

Supplemental Restraint System (SRS) "AIR BAG" and "SEAT BELT PRE-TENSIONER"

The Supplemental Restraint System "Air Bag" and "Seat Belt Pre-tensioner", used along with a seat belt, help to reduce the risk or severity of injury to the driver and front passenger in a frontal collision. The Supplemental Restraint System consists of air bag modules (located in the center of the steering wheel and on the instrument panel on the passenger side), seat belt pre-tensioners, a diagnosis sensor unit, warning lamp, wiring harness and spiral cable.

WARNING:

- To avoid rendering the SRS inoperative, which could increase the risk of personal injury or death in the event of a collision which would result in air bag inflation, all maintenance must be performed by an authorized NISSAN dealer.
- Improper maintenance, including incorrect removal and installation of the SRS, can lead to personal injury caused by unintentional activation of the system.
- All SRS air bag electrical wiring harnesses and connectors are covered with yellow outer insulation. Do not use electrical test equipment on any circuit related to the SRS.

TROUBLE DIAGNOSES — Supplemental Restraint System (SRS)

Wiring Diagram — SRS —

RS-SRS-01

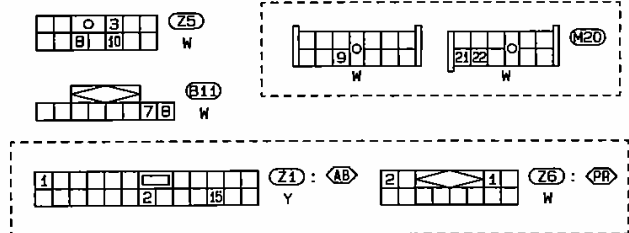
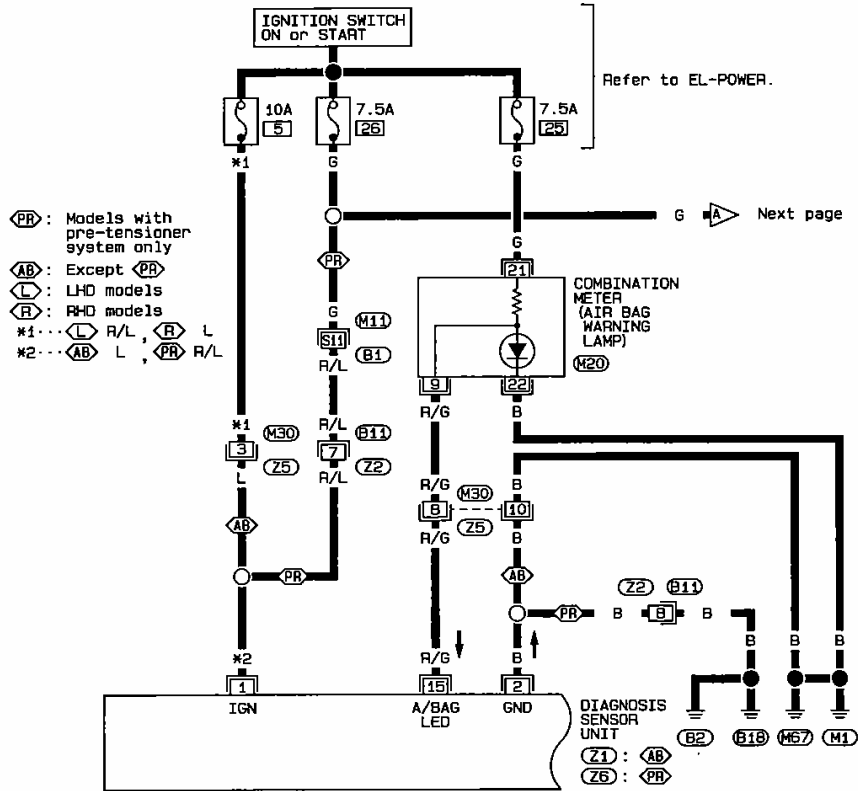

Refer to last page (Foldout page).
(M11), (B1)

RS

SRS007

TROUBLE DIAGNOSES — Supplemental Restraint System (SRS)

Wiring Diagram — SRS — (Cont'd)

RS-SRS-02

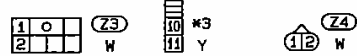
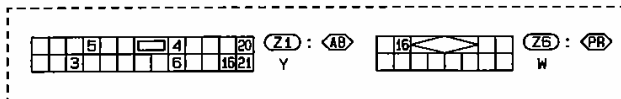
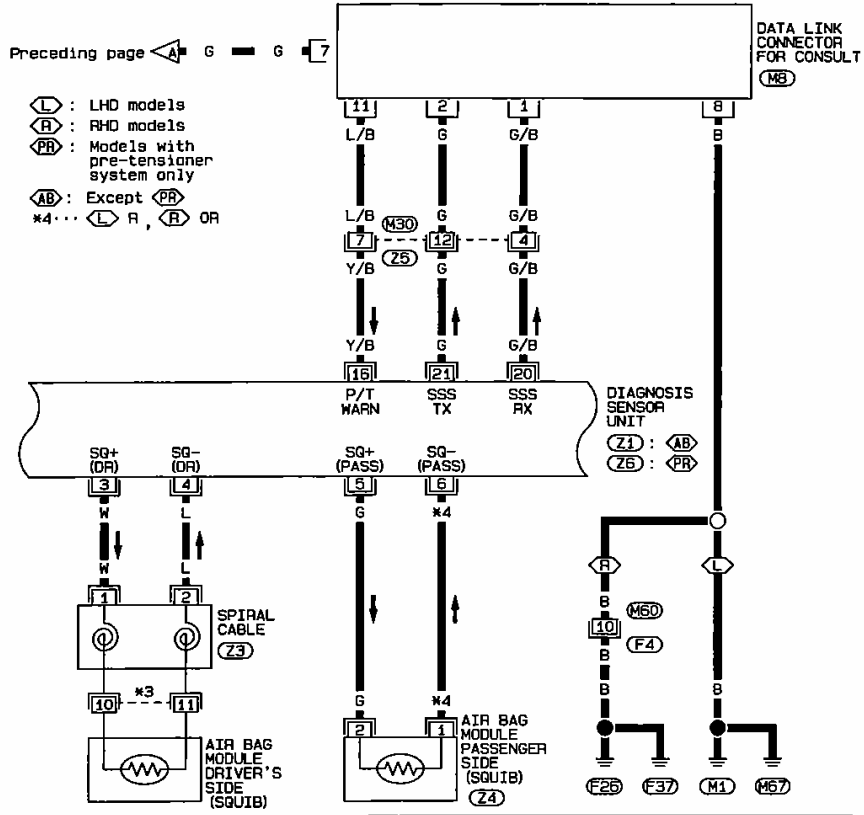

Refer to last page (Foldout page).
(M60), (F4)

SR5008

TROUBLE DIAGNOSES — Supplemental Restraint System (SRS)

Wiring Diagram — SRS — (Cont'd)

RS-SRS-03

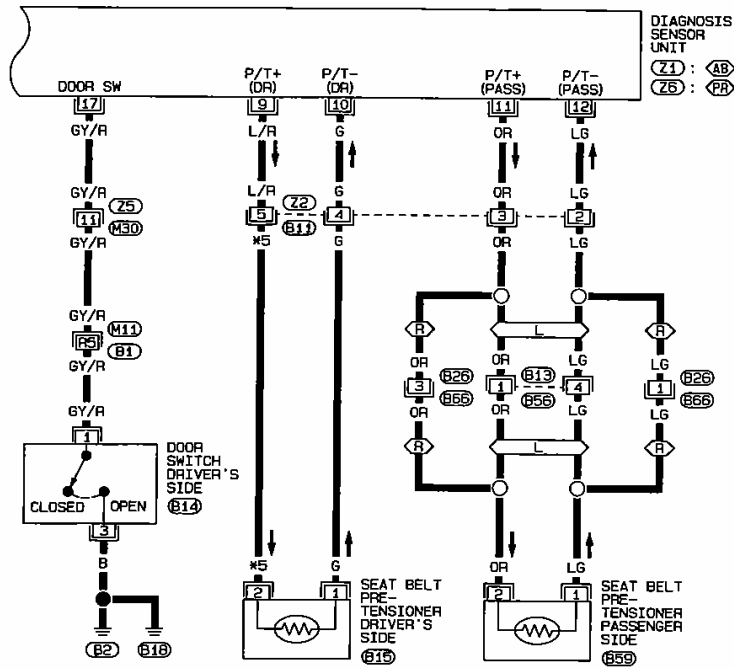

- ◁ L ▷ : LHD models
- ◁ R ▷ : RHD models
- ◁ PR ▷ : Models with pre-tensioner system only
- ◁ AB ▷ : Except ◁ PR ▷
- M5... ◁ L/R ▷, ◁ R ▷ L/G

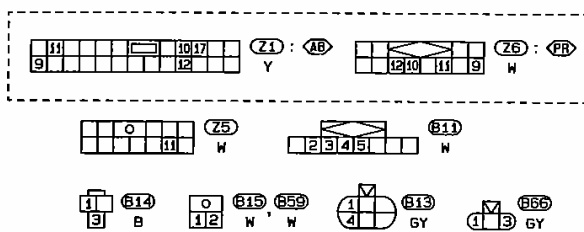

Refer to last page (foldout page).

M11, B1

RS

HRS011

HEATER & AIR CONDITIONER

SECTION **HA**

MODIFICATION NOTICE:

- On RHD models for Europe, the triple-pressure switch has been replaced by a dual-pressure switch.
- Wiring diagrams have been changed.

CONTENTS

MANUAL	MANUAL AND AUTO
TROUBLE DIAGNOSES	SERVICE PROCEDURES
Circuit Diagram — Manual Air Conditioner	Refrigerant Lines
Wiring Diagram — A/C, M —	SERVICE DATA AND SPECIFICATIONS (SDS)
Diagnostic Procedure 6	General Specifications
Electrical Components Inspection	Inspection and Adjustment
AUTO	
TROUBLE DIAGNOSES	
Wiring Diagram — A/C, A —	

HA

Circuit Diagram — Manual Air Conditioner

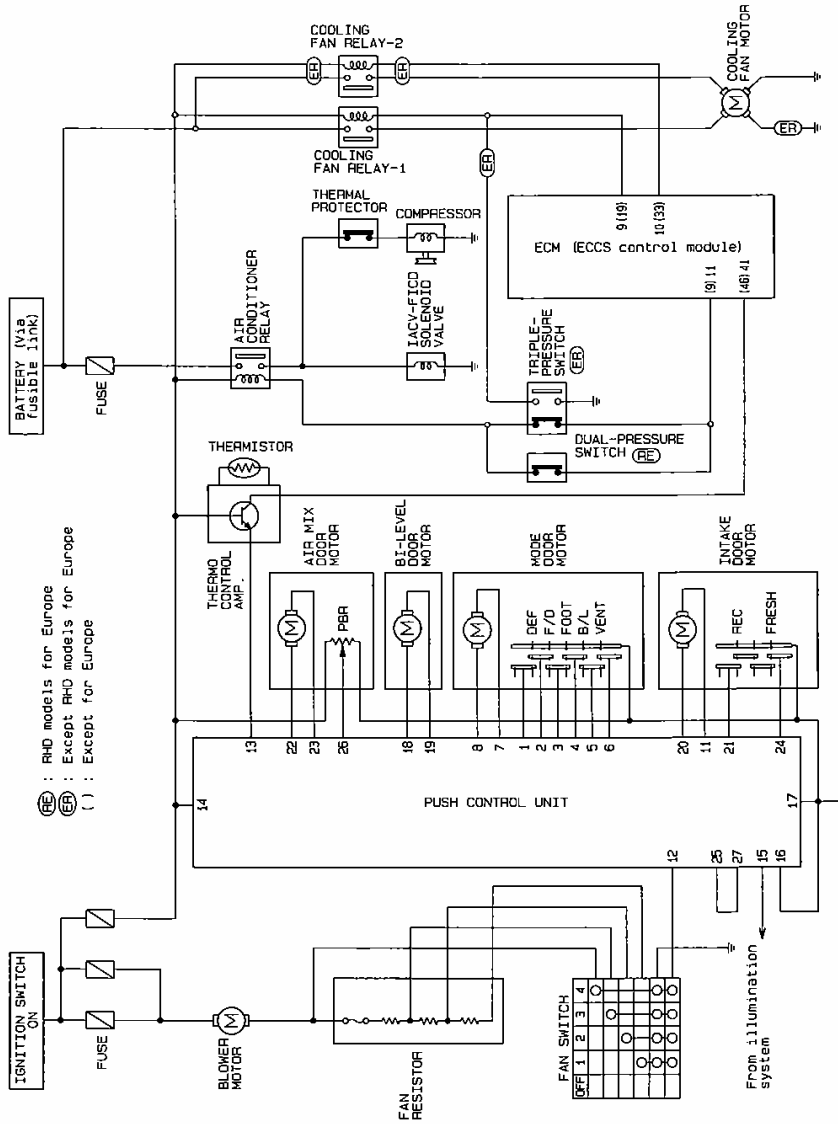

HHA004

Wiring Diagram — A/C, M —

LHD MODEL

HA-A/C, M-01

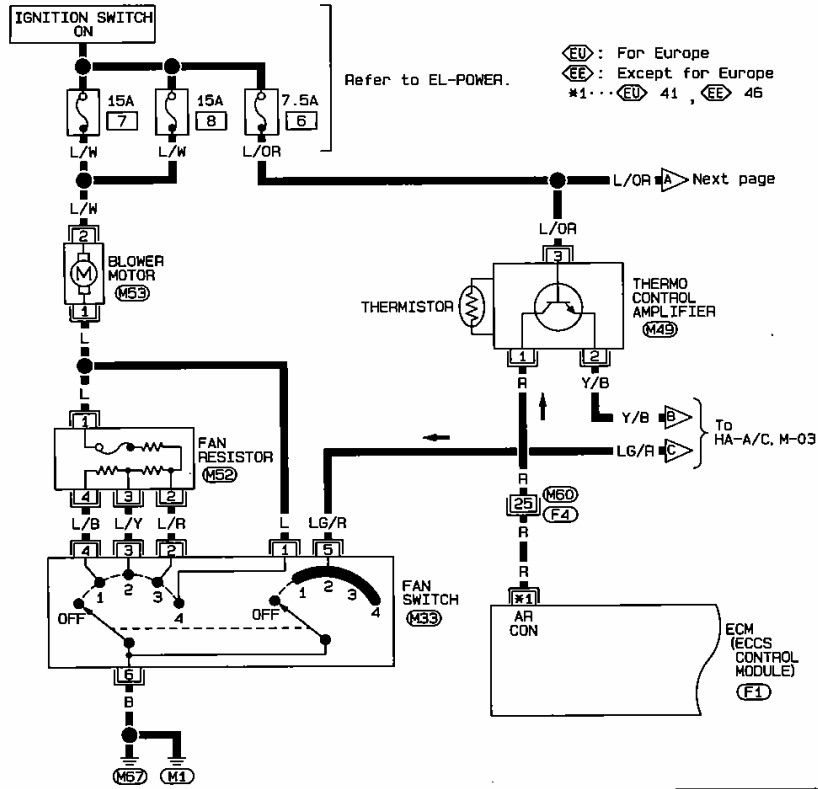

Refer to last page (Foldout page).

(M50), (F4)
(F1)

HA

Wiring Diagram — A/C, M — (Cont'd)

HA-A/C, M-02

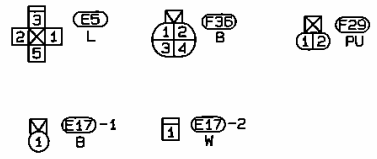
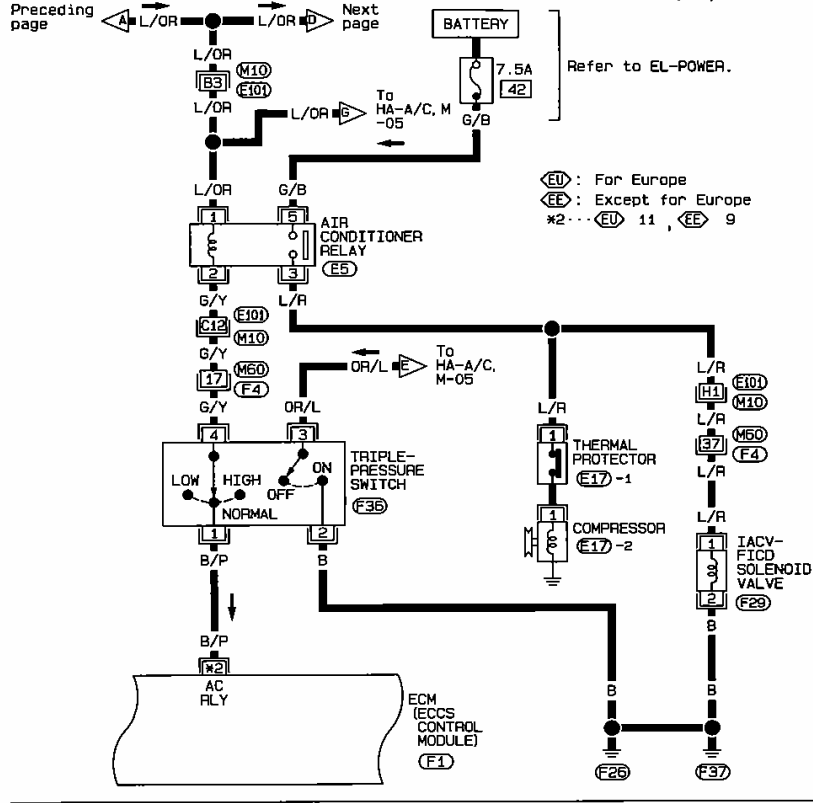

Refer to last page (Foldout page).

(M10), (E101)
 (M60), (F4)
 (F1)

Wiring Diagram — A/C, M — (Cont'd)

HA-A/C, M-03

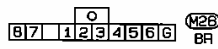
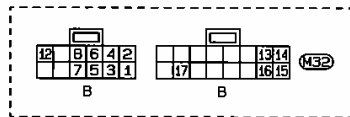
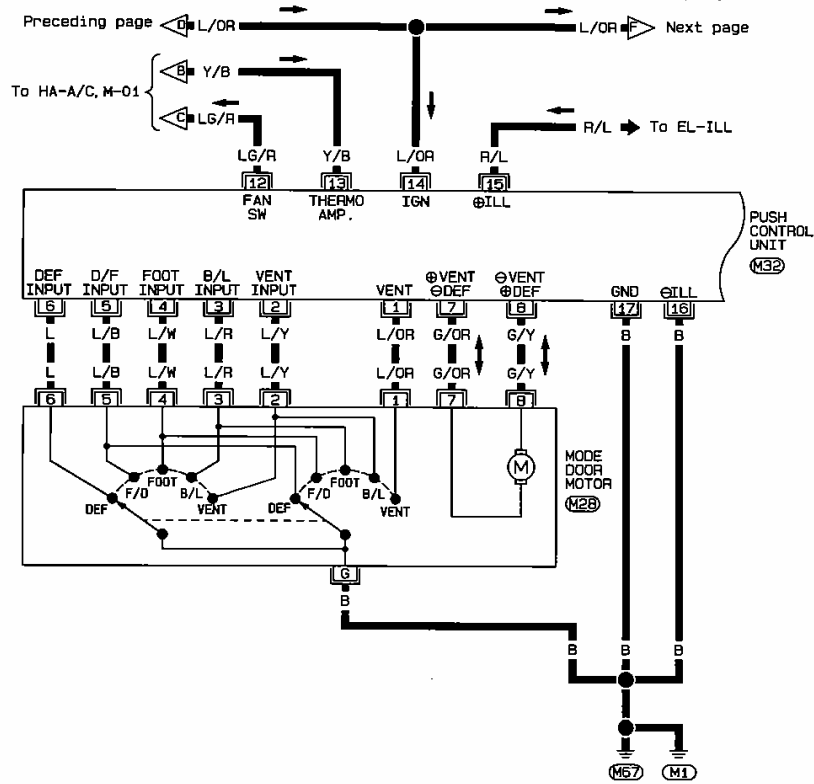

HA

TROUBLE DIAGNOSES

MANUAL

Wiring Diagram — A/C, M — (Cont'd)

HA-A/C, M-04

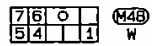
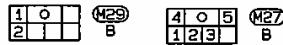
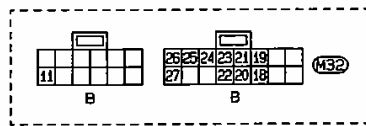
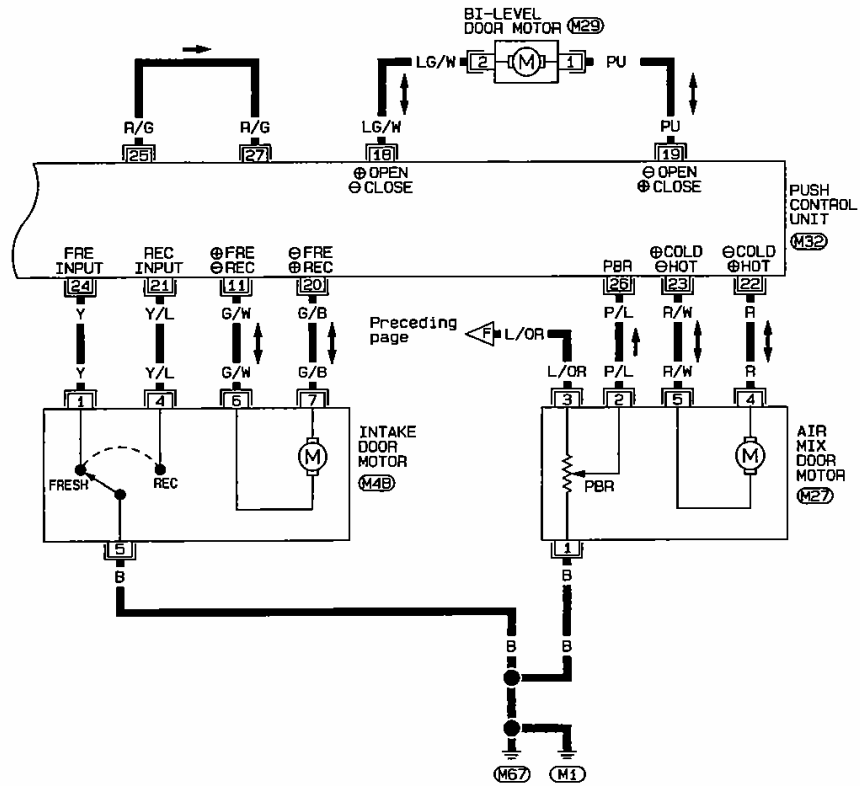

Wiring Diagram — A/C, M — (Cont'd)

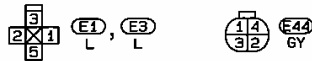
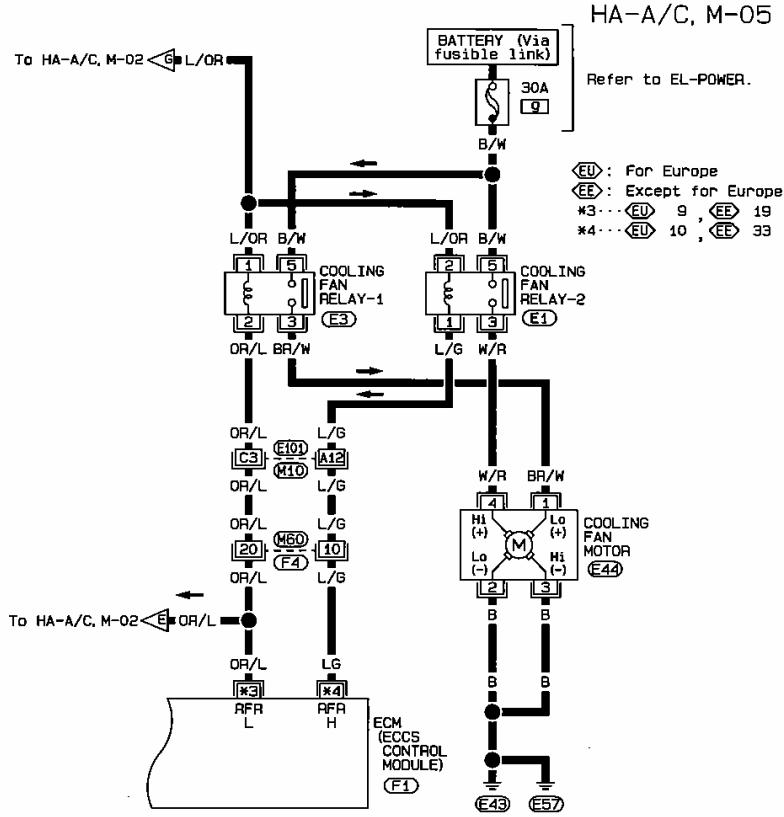

Refer to last page (Foldout page).

ⓔ10, ⓔ11

ⓔ60, ⓔ4

ⓔ1

HA

TROUBLE DIAGNOSES

MANUAL

Wiring Diagram — A/C, M — (Cont'd)

RHD MODEL

HA-A/C, M-06

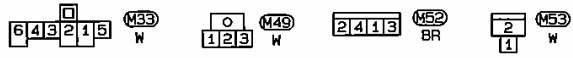
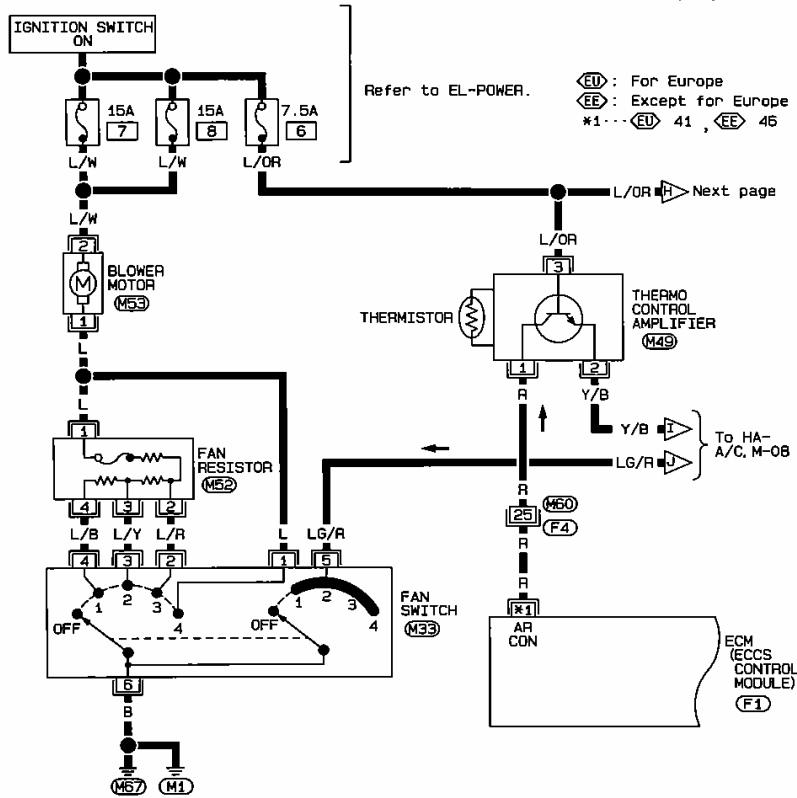

Refer to last page (Foldout page).

M60, F4
 F1

Wiring Diagram — A/C, M — (Cont'd)

HA-A/C, M-07

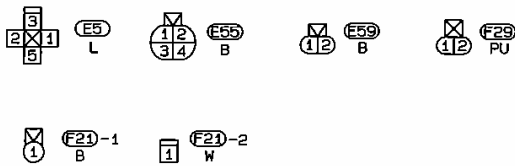
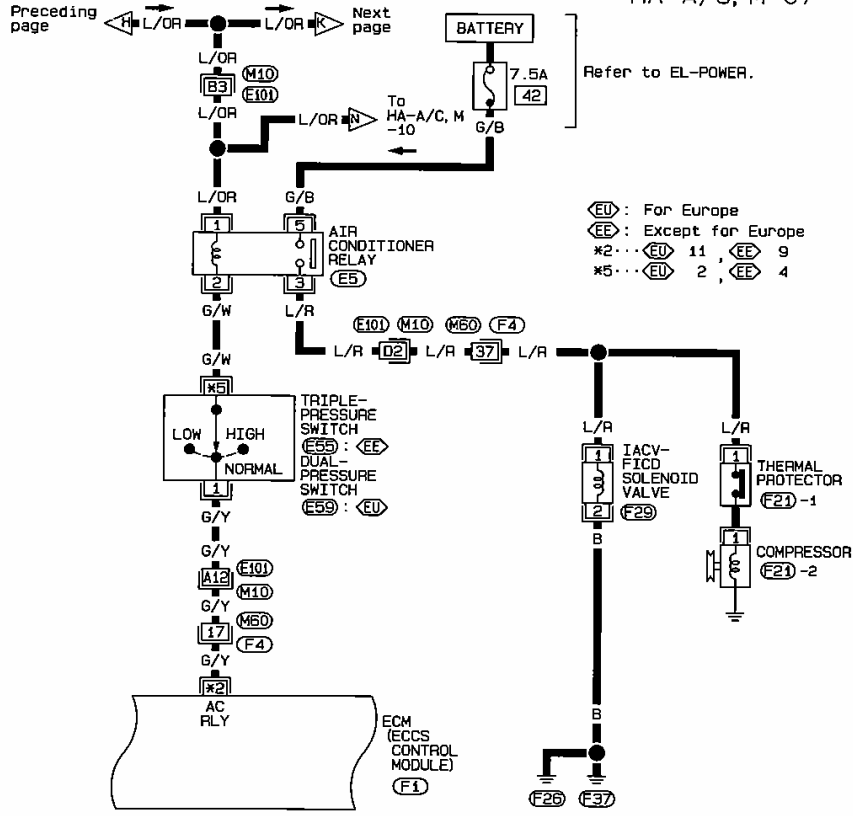

Refer to last page (Foldout page).

- <M10> , <E101>
- <M50> , <F4>
- <F1>

HA

Wiring Diagram — A/C, M — (Cont'd)

HA-A/C, M-08

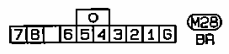
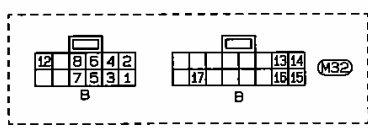
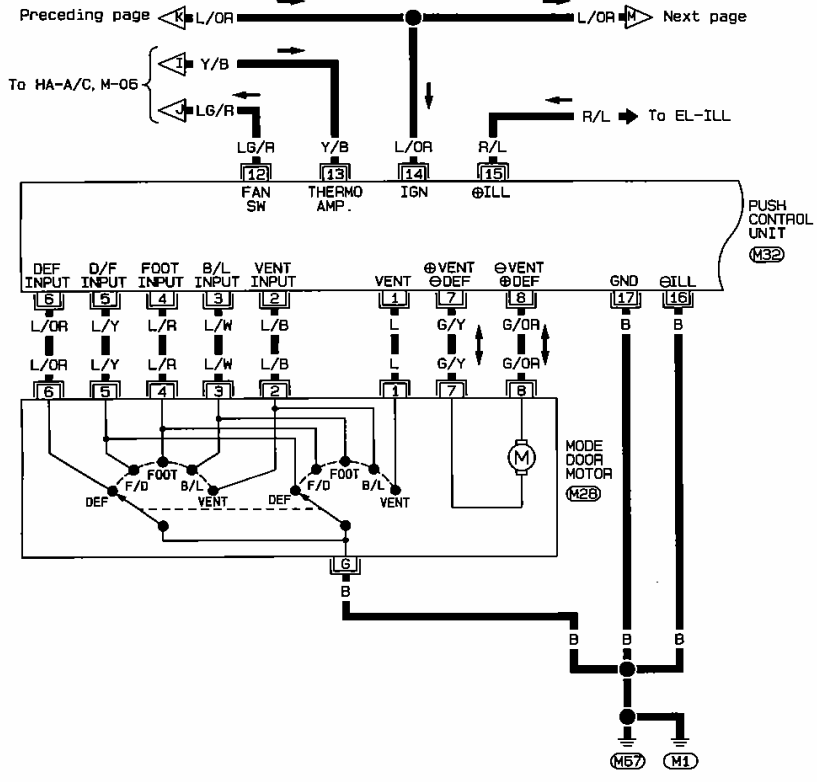

TROUBLE DIAGNOSES

MANUAL

Wiring Diagram — A/C, M — (Cont'd)

HA-A/C, M-09

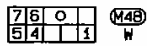
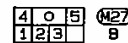
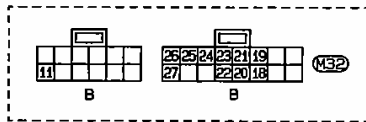
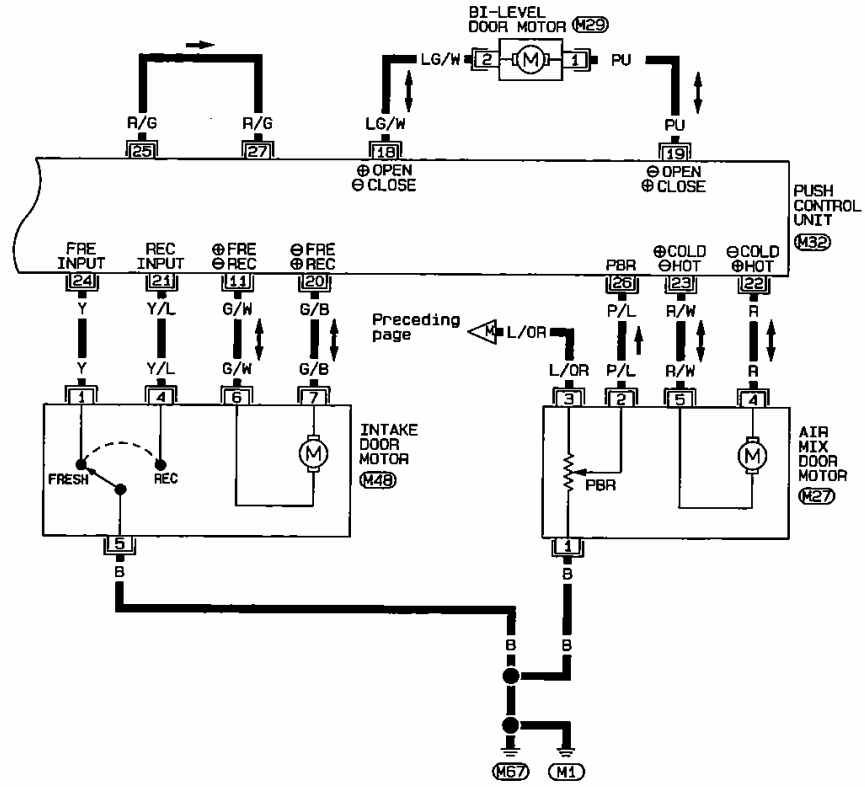

HA

SHA465E

Wiring Diagram — A/C, M — (Cont'd)

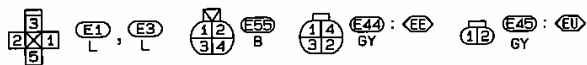
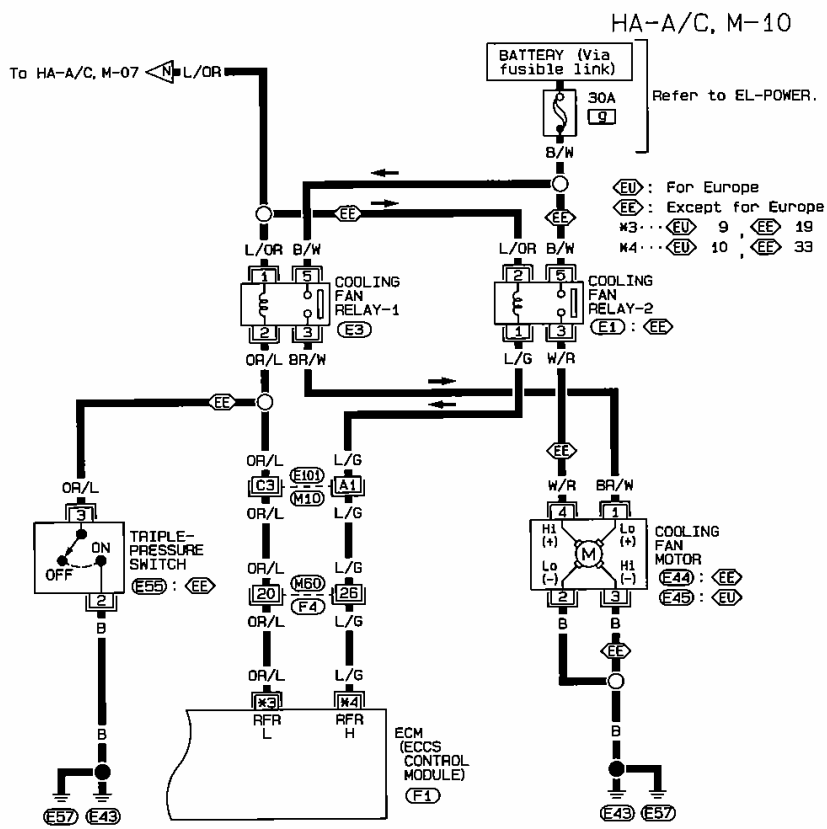

Refer to last page (foldout page).

- $\langle \text{M10} \rangle$, $\langle \text{E10} \rangle$
- $\langle \text{M60} \rangle$, $\langle \text{F4} \rangle$
- $\langle \text{F1} \rangle$

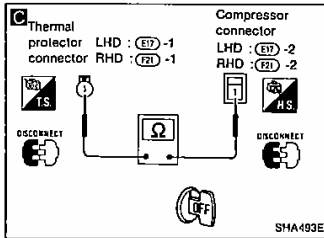
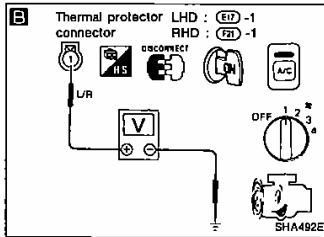
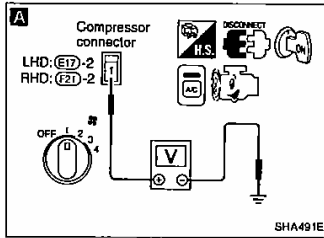

Diagnostic Procedure 6

SYMPTOM: Magnet clutch does not operate when A/C switch and fan switch are ON.

- Perform PRELIMINARY CHECK 2 before referring to the following flow chart.

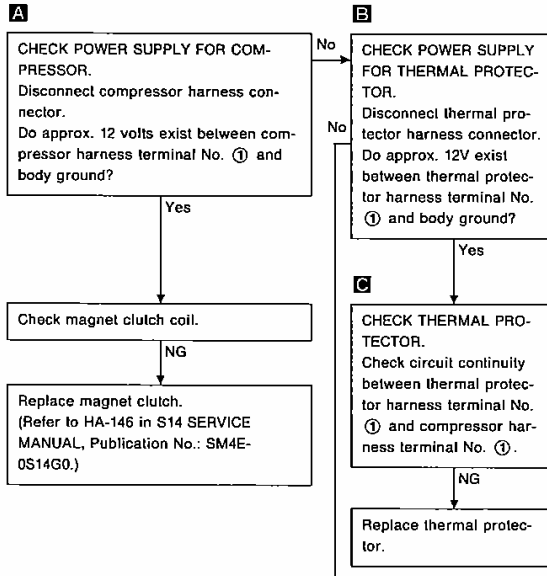

(Go to next page.)

Diagnostic Procedure 6 (Cont'd)

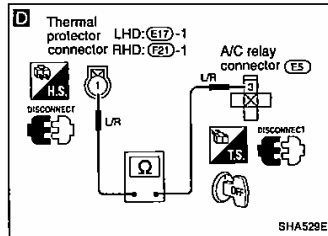

A

Disconnect A/C relay harness connector.

D Note
Check circuit continuity between A/C relay harness terminal No. ③ and thermal protector harness terminal No. ①.

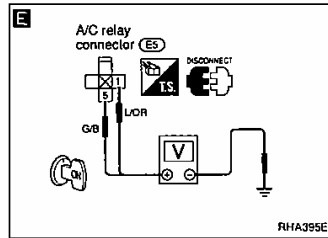

OK

E CHECK POWER SUPPLY FOR A/C RELAY.
Disconnect A/C relay.
Do approx. 12 volts exist between A/C relay harness terminal No. ①, ⑤ and body ground?

No → CHECK POWER SUPPLY CIRCUIT AND 7.5A FUSES AT FUSE BLOCK. (Refer to "POWER SUPPLY ROUTING" in EL section and Wiring Diagram.)

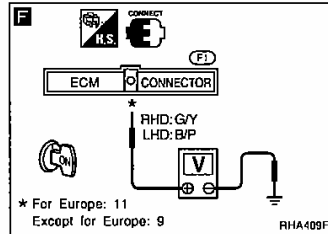

Yes → CHECK A/C RELAY AFTER DISCONNECTING IT. (Refer to HA-70 in S14 SERVICE MANUAL, Publication No.: SM4E-0S14G0.)

NG → Replace A/C relay.

OK

Reconnect A/C relay.

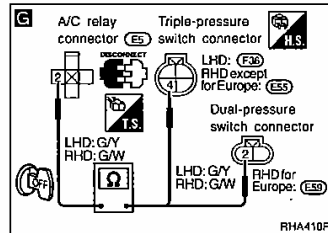

F CHECK COIL SIDE CIRCUIT OF A/C RELAY.
Do approx. 12 volts exist between ECM (ECCS control module) harness terminal No. ⑨ or ⑪ and body ground?

No → **C** Note
Check circuit continuity between A/C relay harness terminal No. ② and triple-pressure switch harness terminal No. ④ or dual-pressure switch harness terminal No. ②.

Yes → (Go to next page.)

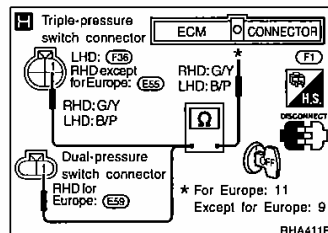

OK

H Note
Check circuit continuity between triple or dual-pressure switch harness terminal No. ① and ECM (ECCS control module) harness terminal No. ⑨ or ⑪. [For terminal arrangement, refer to last page (Foldout page).]

OK

Note: If the result is NG after checking circuit continuity, repair harness or connector.

- CHECK TRIPLE-PRESSURE SWITCH. (Refer to HA-69 in S14 SERVICE MANUAL, Publication No.: SM4E-0S14G0.)
- CHECK DUAL-PRESSURE SWITCH. Refer to HA-17.

Diagnostic Procedure 6 (Cont'd)

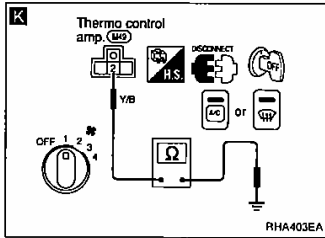
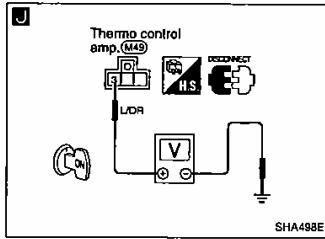
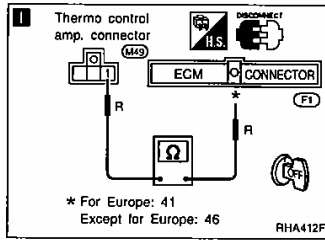

⑧
Disconnect thermo control amp. harness connector.

I Note
Check circuit continuity between thermo control amp. harness terminal No. ① and ECM (ECCS control module) harness terminal No. ④ or ⑤.

J OK
CHECK POWER SUPPLY FOR THERMO CONTROL AMP.
Disconnect thermo control amp. harness connector.
Do approx. 12 volts exist between thermo control amp. harness terminal No. ③ and body ground?

No
Check 7.5A fuse at fuse block.
Refer to EL section ("Wiring Diagram", "POWER SUPPLY ROUTING").

K Yes
CHECK BODY GROUND CIRCUIT FOR THERMO CONTROL AMP.
Turn A/C switch or DEF switch ON.
Check for continuity between thermo control amp. harness terminal ② and body ground.

NG
Disconnect push control unit harness connector.

③
(Go to next page.)

OK
CHECK THERMO CONTROL AMP.
(Refer to HA-68 in S14 SERVICE MANUAL, Publication No.: SM4E-0S14G0.)

NG
Replace thermo control amp.

OK
Check voltage between ECM (ECCS control module) harness terminals ③, ④ and body ground.
Refer to EC section ("ECM Terminals and Reference Value", "TROUBLE DIAGNOSES — General Description") in S14 SERVICE MANUAL, Publication No.: SM4E-0S14G0.

HA

Note:
If the result is NG after checking circuit continuity, repair harness or connector.

Diagnostic Procedure 6 (Cont'd)

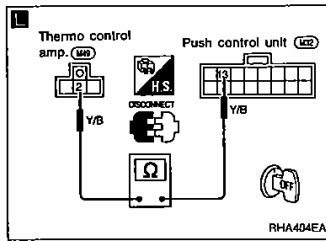

L Note
 Check circuit continuity between thermo control amp. harness terminal No. ② and push control unit harness terminal No. ⑫.

OK
 Disconnect fan switch harness connector.

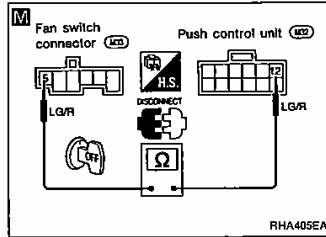

M Note
 Check circuit continuity between push control unit terminal No. ⑫ and fan switch harness terminal No. ⑤.

OK
N Note
 CHECK BODY GROUND CIRCUIT FOR FAN SWITCH.
 Check for continuity between fan switch harness terminal ⑤ and body ground.

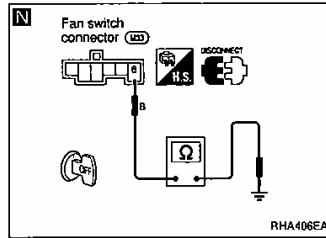

OK
N Note
 CHECK FAN SWITCH.
 (Refer to HA-68 in S14 SERVICE MANUAL, Publication No.: SM4E-0S14G0.)

NG → Replace fan switch.

OK
 Replace push control unit.

Note:
 If the result is NG after checking circuit continuity, repair harness or connector.

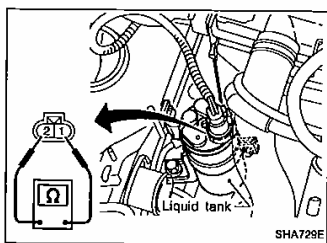

Electrical Components Inspection

DUAL-PRESSURE SWITCH

RHD models for Europe

	ON kPa (bar, kg/cm ² , psi)	OFF kPa (bar, kg/cm ² , psi)
Low-pressure side	Increasing to 157 - 216 (1.57 - 2.16, 1.6 - 2.2, 23 - 31)	Decreasing to 152.0 - 201.0 (1.520 - 2.010, 1.55 - 2.05, 22.0 - 29.2)
High-pressure side	Decreasing to 1,275 - 1,667 (12.7 - 16.7, 13 - 17, 185 - 242)	Increasing to 2,452 - 2,844 (24.5 - 28.4, 25 - 29, 356 - 412)

HA

Wiring Diagram — A/C, A —

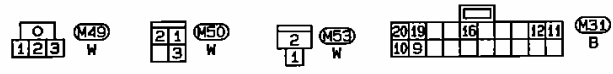
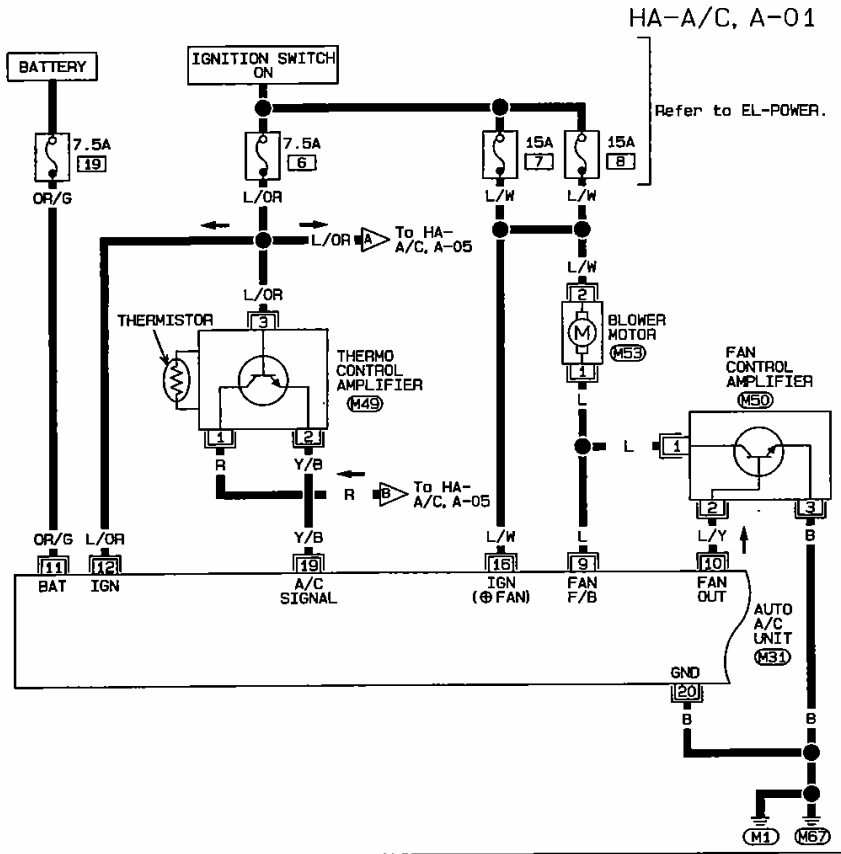

TROUBLE DIAGNOSES

AUTO

Wiring Diagram — A/C, A — (Cont'd)

HA-A/C, A-02

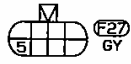
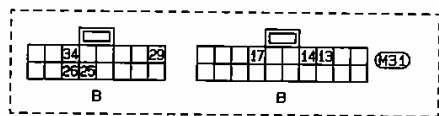
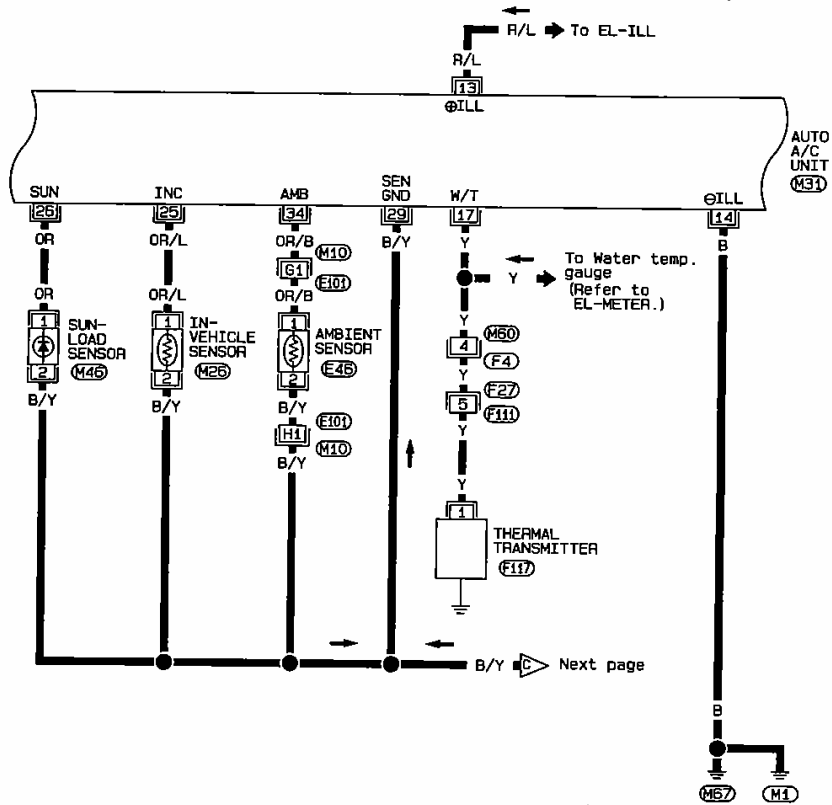

Refer to last page (Foldout page).

- M10, E101
- M50, F4



HA

TROUBLE DIAGNOSES

AUTO

Wiring Diagram — A/C, A — (Cont'd)

HA-A/C, A-03

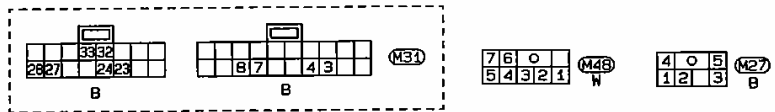
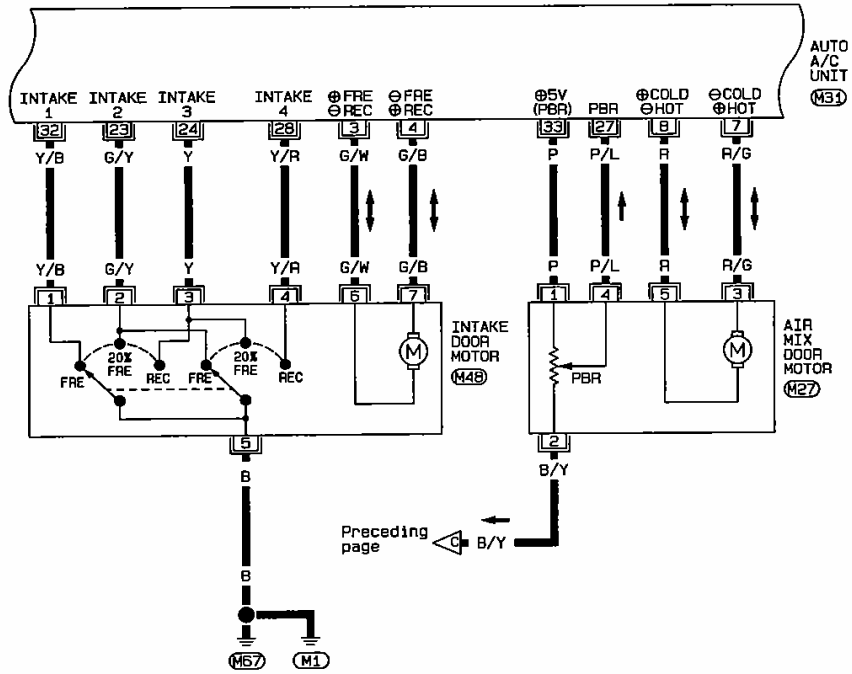

TROUBLE DIAGNOSES

AUTO

Wiring Diagram — A/C, A — (Cont'd)

HA-A/C, A-04

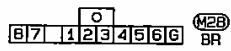
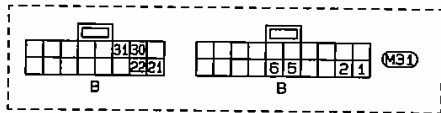
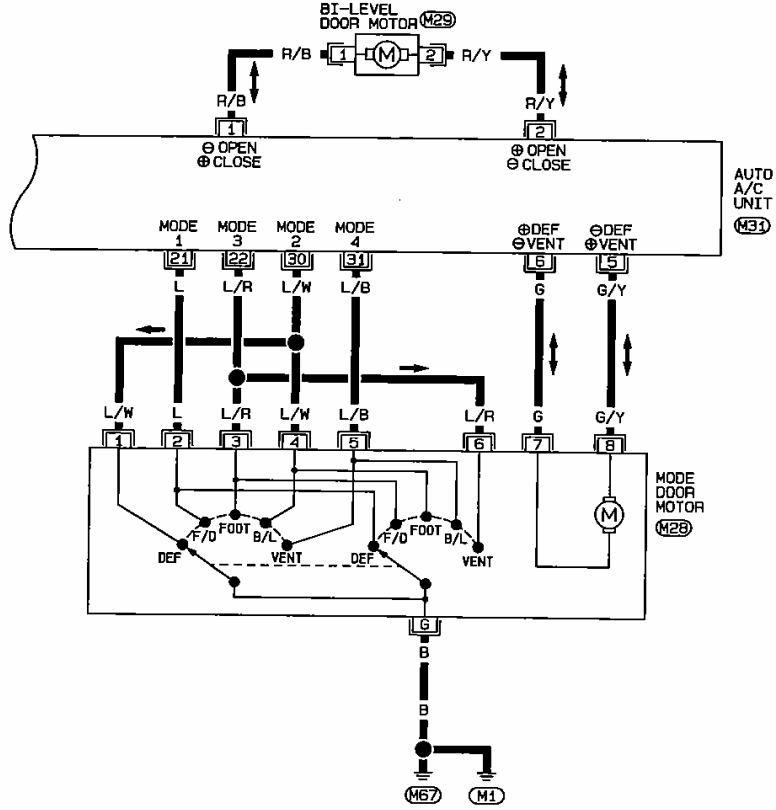

HA

TRUBLE DIAGNOSES

AUTO

Wiring Diagram — A/C, A — (Cont'd)

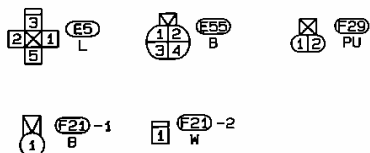
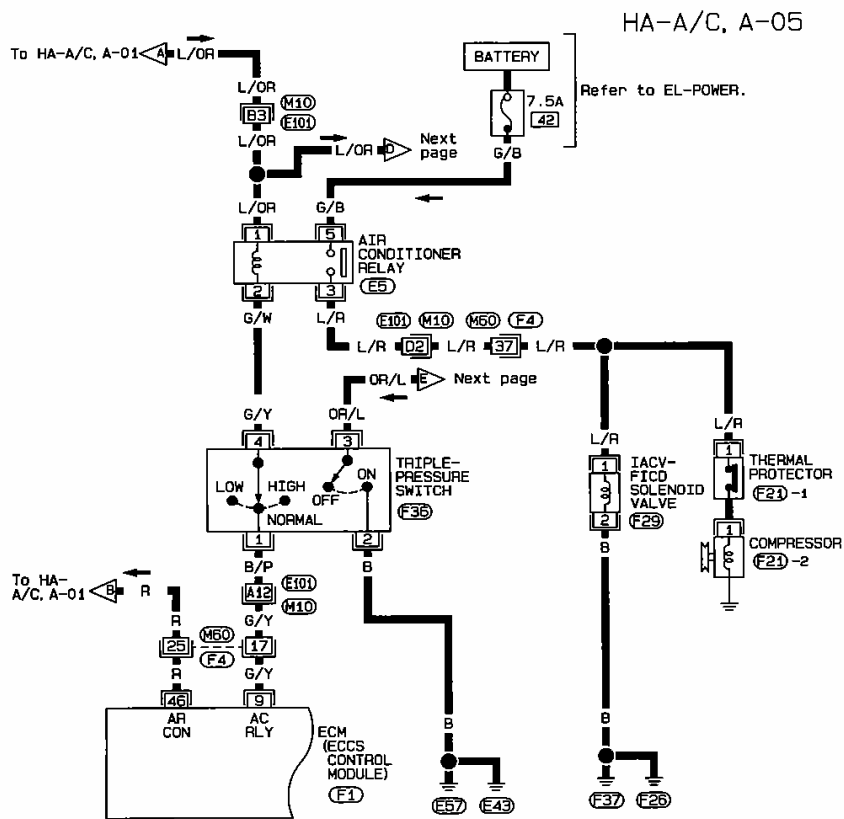

Refer to last page (foldout page).

(M10, E10)

(M60, F4)

(F1)

HH-A043

TROUBLE DIAGNOSES

AUTO

Wiring Diagram — A/C, A — (Cont'd)

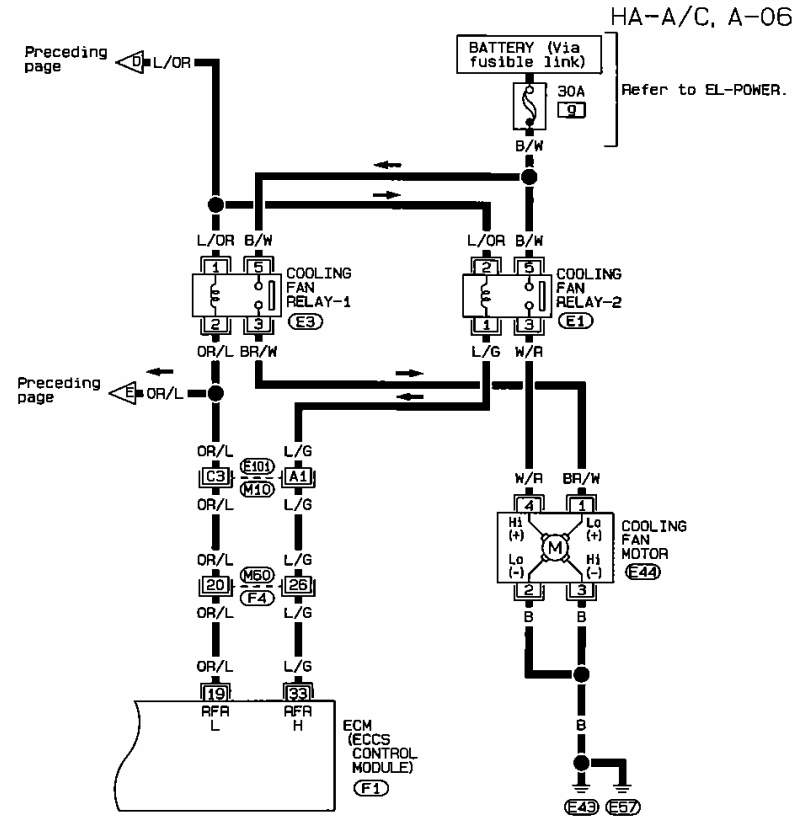

Refer to last page (Foldout page).

(M10), (E10)

(M60), (F4)

(F1)

HA

LHD MODEL

Refrigerant Lines

SEC. 271-272-276

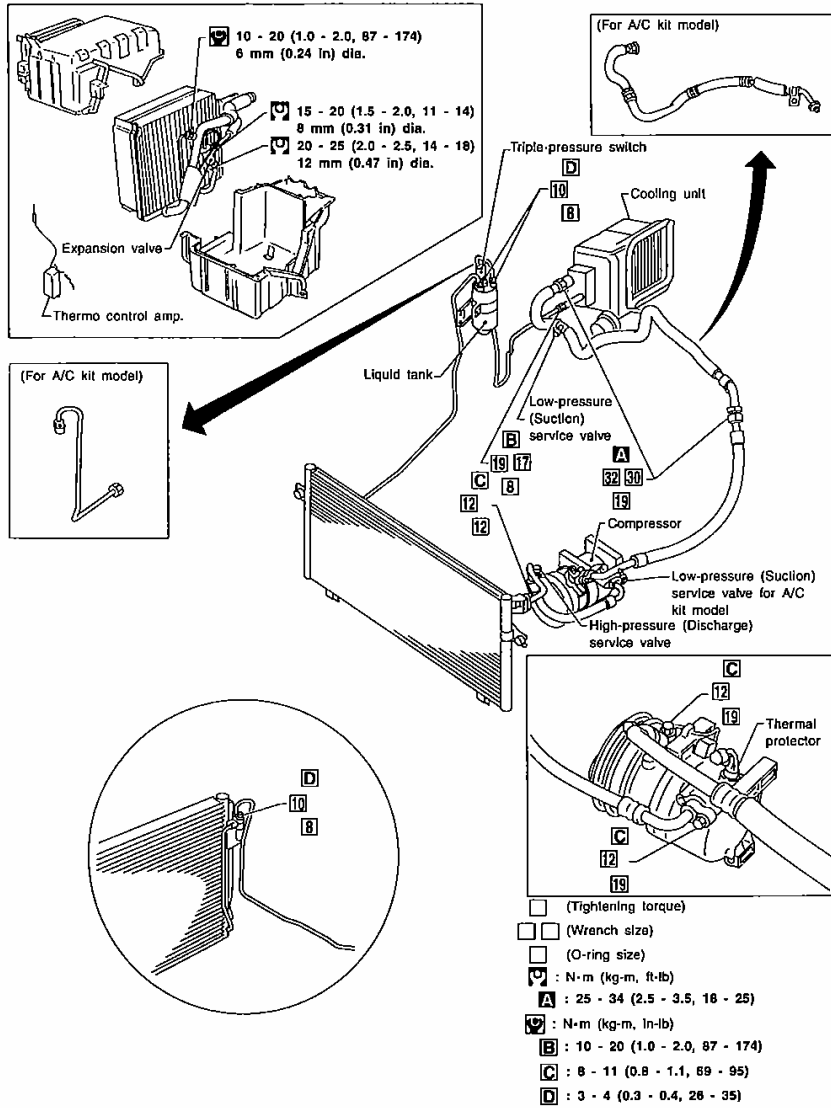

RHA413F

General Specifications

COMPRESSOR

Model	DKV-14C
Type	Vane rotary
Displacement cm ³ (cu in)/Rev	140 (8.54)
Direction of rotation	Clockwise (Viewed from drive end)
Drive belt	Poly V type

LUBRICANT

Model	ZEXEL make DKV-14C
Name	Nissan A/C System Oil Type R
Part No.	KLH00-RAGR0
Capacity ml (Imp fl oz)	
Total in system	200 (7.0)
Compressor (Service part) charging amount	200 (7.0)

REFRIGERANT

Type	HFC-134a (R-134a)
Capacity kg (lb)	0.60 - 0.70 (1.32 - 1.54)

Inspection and Adjustment

ENGINE IDLING SPEED

When A/C is ON

- Refer to EC section ("Inspection and Adjustments", "SERVICE DATA AND SPECIFICATIONS").

BELT TENSION

- Refer to MA section ("Checking Drive Belts", "ENGINE MAINTENANCE").

COMPRESSOR

Model	DKV-14C
Clutch disc-pulley clearance mm (in)	0.3 - 0.6 (0.012 - 0.024)

HA

ELECTRICAL SYSTEM

SECTION **EL**

When you read wiring diagrams:

● Read G1 section, "HOW TO READ WIRING DIAGRAMS".

When you perform trouble diagnoses, read G1 section, "HOW TO FOLLOW FLOW CHART IN TROUBLE DIAGNOSES" and "HOW TO PERFORM EFFICIENT DIAGNOSIS FOR AN ELECTRICAL INCIDENT".

CONTENTS

PRECAUTIONS	2	POWER WINDOW	46
Supplemental Restraint System (SRS) "AIR BAG" and "SEAT BELT PRE-TENSIONER".....	2	Schematic.....	46
POWER SUPPLY ROUTING	4	Wiring Diagram — WINDOW —.....	47
Schematic.....	4	Trouble Diagnoses.....	50
Wiring Diagram — POWER —.....	6	POWER DOOR MIRROR	51
BATTERY	15	Wiring Diagram — MIRROR —.....	51
Service Data and Specifications (SDS).....	15	MULTI-REMOTE CONTROL SYSTEM	53
STARTING SYSTEM	16	Wiring Diagram — MULTI —.....	53
Construction.....	16	THEFT WARNING SYSTEM	57
Service Data and Specifications (SDS).....	16	Wiring Diagram — THEFT —.....	57
EXTERIOR LAMP	17	NATS (Nissan Anti-Theft System)	63
Front Fog Lamp/Wiring Diagram — F/FOG.....	17	System Description.....	63
Rear Fog Lamp/Wiring Diagram — R/FOG.....	19	System Composition.....	63
Turn Signal and Hazard Warning Lamps/Schematic.....	21	Component Parts Location.....	64
Turn Signal and Hazard Warning Lamps/Wiring Diagram — TURN.....	22	Wiring Diagram — NATS —.....	65
INTERIOR LAMP	27	Trouble Diagnoses.....	67
Illumination/Schematic.....	27	LOCATION OF ELECTRICAL UNIT	82
Illumination/Wiring Diagram — ILL.....	28	Passenger Compartment.....	82
Interior, Spot and Trunk Room Lamps/Wiring Diagram — INT/L.....	33	HARNESS LAYOUT	84
METER AND GAUGES	35	Main Harness.....	84
Combination Meter.....	35	Engine Room Harness.....	88
Speedometer, Tachometer, Temp. and Fuel Gauges/Wiring Diagram — METER.....	36	Engine Control Harness.....	92
WARNING LAMPS AND BUZZER	37	Body Harness.....	96
Warning Lamps/Schematic.....	37	Door Harness (LHD models).....	100
Warning Lamps/Wiring Diagram — WARN.....	38	Door Harness (RHD models).....	101
Warning Buzzer/Wiring Diagram — CHIME.....	44	SUPER MULTIPLE JUNCTION (SMJ)	Foldout
		Disconnecting and Connecting.....	Foldout
		Terminal Arrangement.....	Foldout

WIRING DIAGRAM REFERENCE CHART

ECCS	EC SECTION
A/T CONTROL	AT SECTION
ANTI-LOCK BRAKING SYSTEM	BR SECTION
AIR BAG AND SEAT BELT PRE-TENSIONER	RS SECTION
HEATER AND AIR CONDITIONER	HA SECTION

EL

PRECAUTIONS

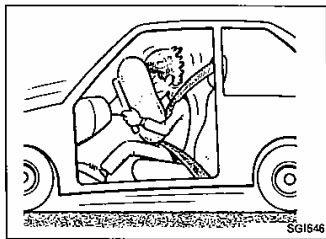

Supplemental Restraint System (SRS) "AIR BAG" and "SEAT BELT PRE-TENSIONER"

The Supplemental Restraint System "Air Bag" and "Seat Belt Pre-tensioner", used along with a seat belt, help to reduce the risk or severity of injury to the driver and front passenger in a frontal collision. The Supplemental Restraint System consists of air bag modules (located in the center of the steering wheel and on the instrument panel on the passenger side), seat belt pre-tensioners, a diagnostic sensor unit, warning lamp, wiring harness and spiral cable. Information necessary to service the system safely is included in the **RS** section of this Service Manual.

WARNING:

- To avoid rendering the SRS inoperative, which could increase the risk of personal injury or death in the event of a collision which would result in air bag inflation, all maintenance must be performed by an authorized NISSAN dealer.
- Improper maintenance, including incorrect removal and installation of the SRS, can lead to personal injury caused by unintentional activation of the system.
- Do not use electrical test equipment on any circuit related to the SRS unless instructed to in this Service Manual. SRS wiring harnesses are covered with yellow insulation either just before the harness connectors or the complete harness, for easy identification.

PRECAUTIONS

NOTE

EL

EL-3

POWER SUPPLY ROUTING

Schematic

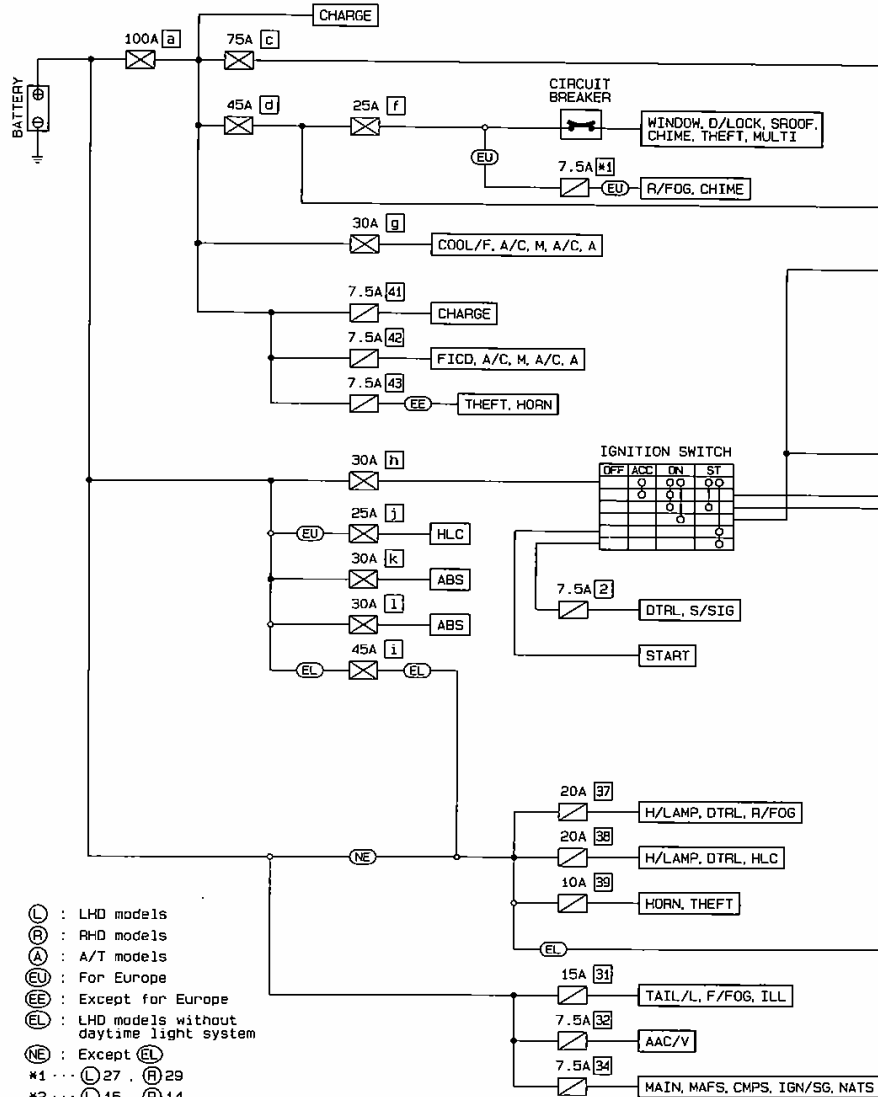

- (L) : LHD models
- (R) : RHD models
- (A) : A/T models
- (EU) : For Europe
- (EE) : Except for Europe
- (EL) : LHD models without daytime light system
- (NE) : Except (EL)
- *1 ... (L) 27, (R) 29
- *2 ... (L) 15, (R) 14
- *3 ... (L) 29, (R) 28
- *4 ... (L) 10A, (R) 15A

POWER SUPPLY ROUTING

Schematic (Cont'd)

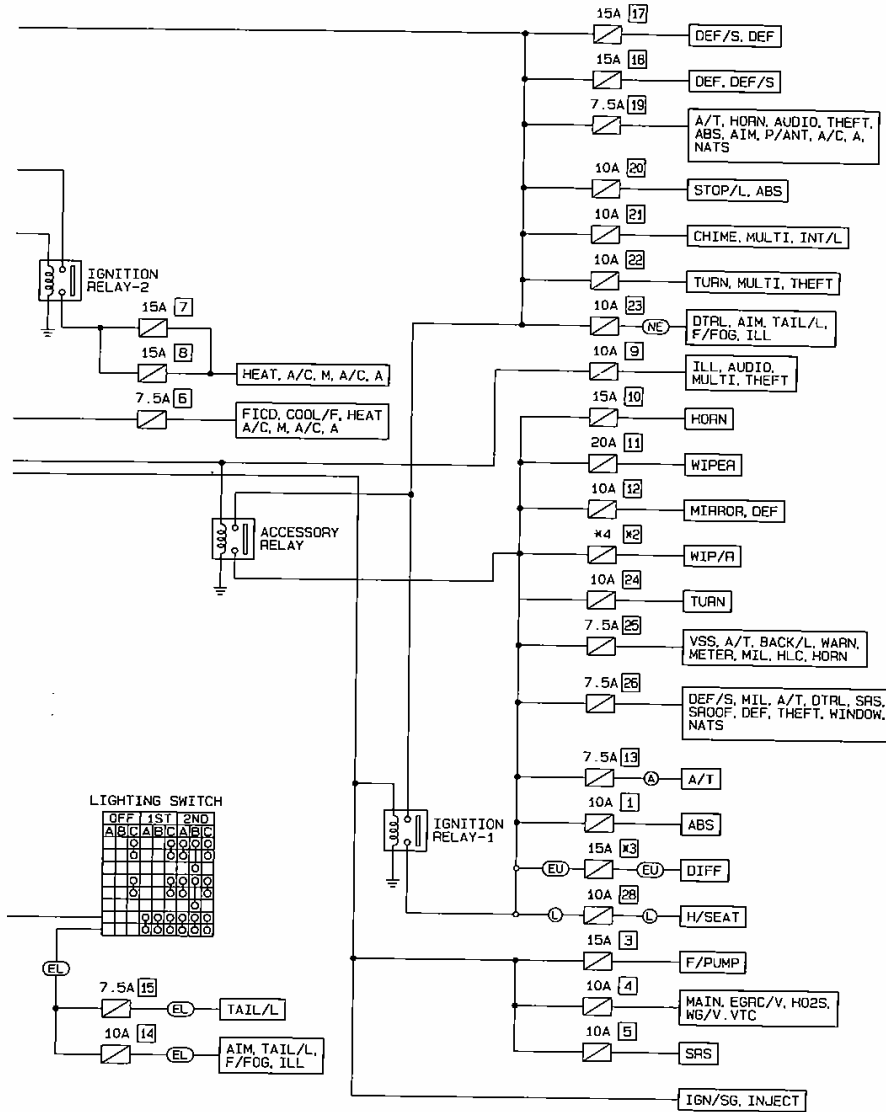

POWER SUPPLY ROUTING

Wiring Diagram — POWER —

EL-POWER-01

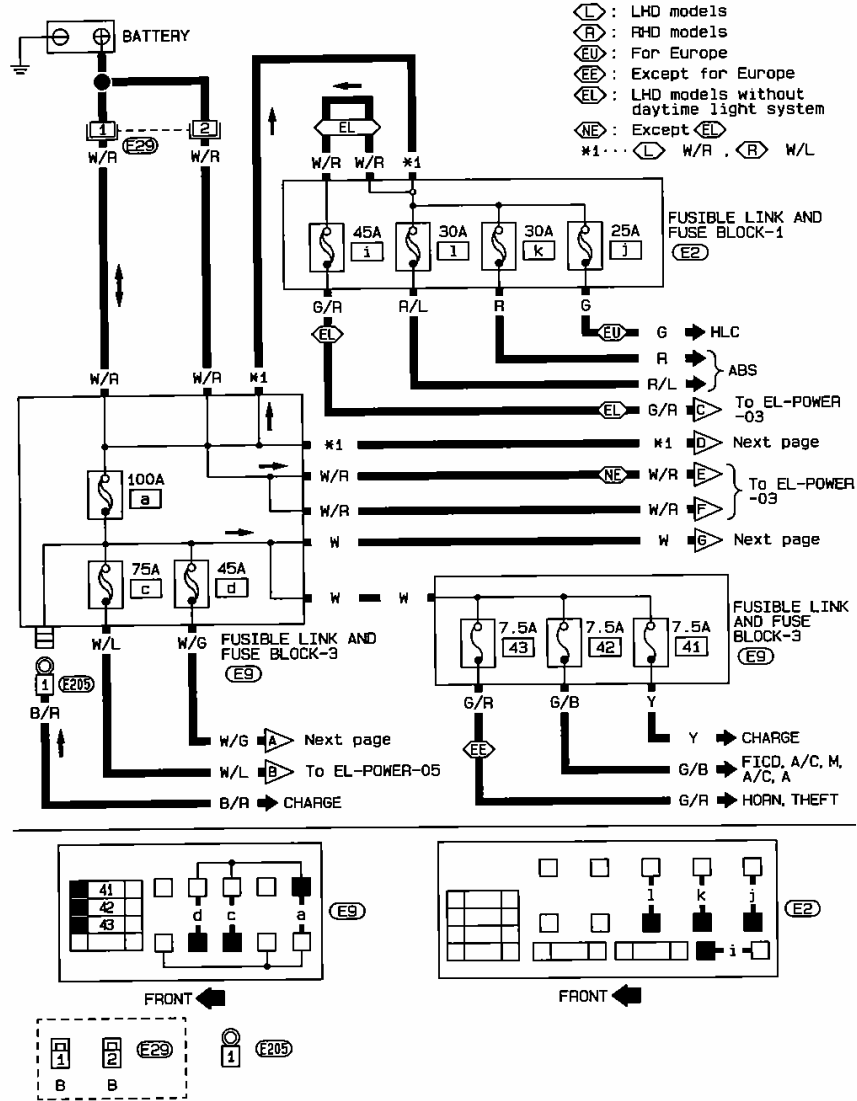

SEL868T

POWER SUPPLY ROUTING

Wiring Diagram — POWER — (Cont'd)

EL-POWER-02

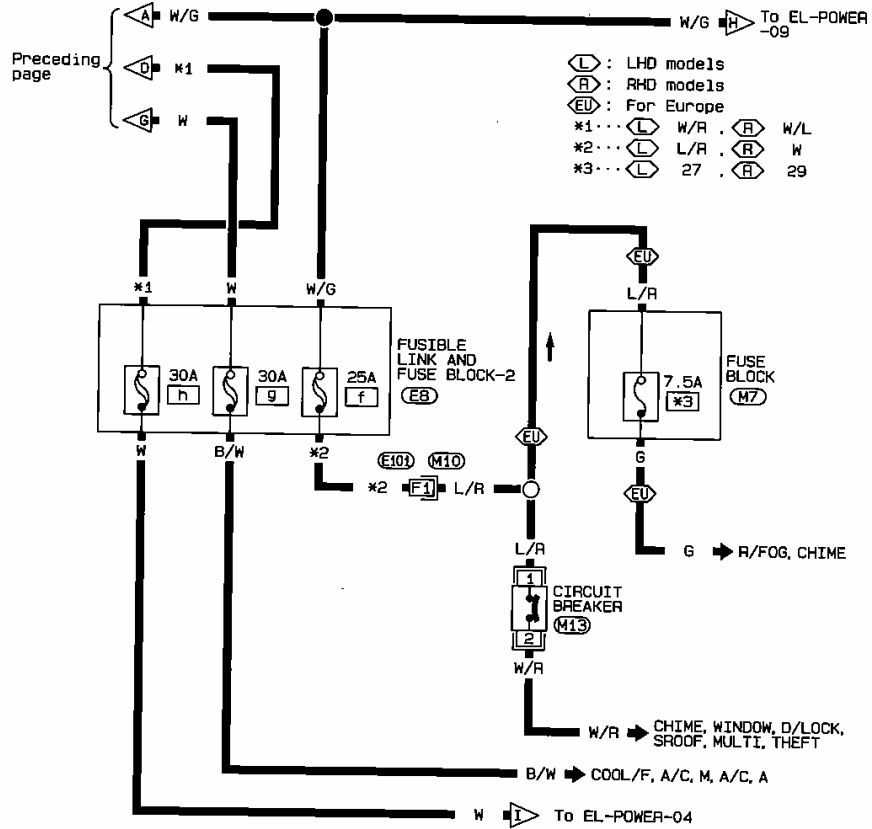

- (L) : LHD models
- (R) : RHD models
- (EU) : For Europe
- *1... (L) W/R . (R) W/L
- *2... (L) L/R . (R) W
- *3... (L) 27 . (R) 29

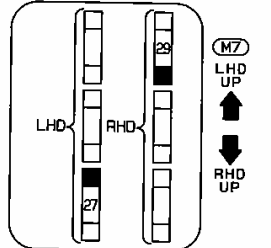
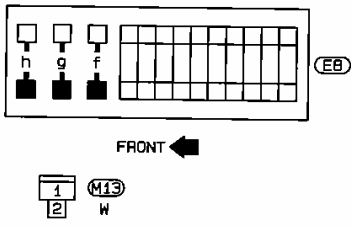

Refer to last page (Foldout page).
(M10), (E10)

EL

POWER SUPPLY ROUTING

Wiring Diagram — POWER — (Cont'd)

EL-POWER-03

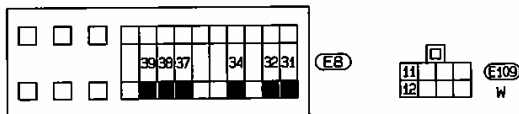
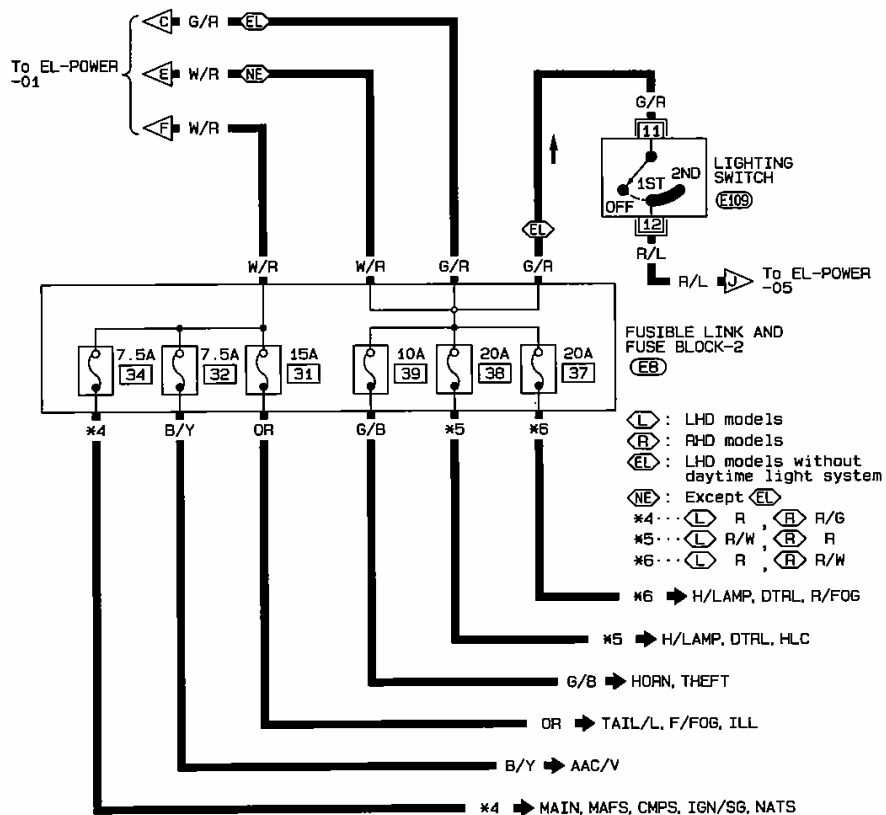

FRONT ←

POWER SUPPLY ROUTING

Wiring Diagram — POWER — (Cont'd)

EL-POWER-04

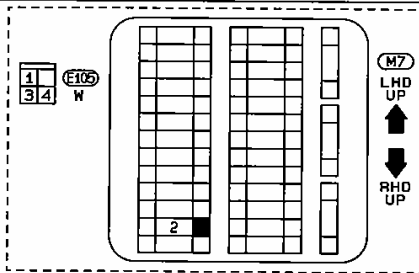
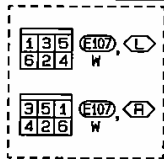
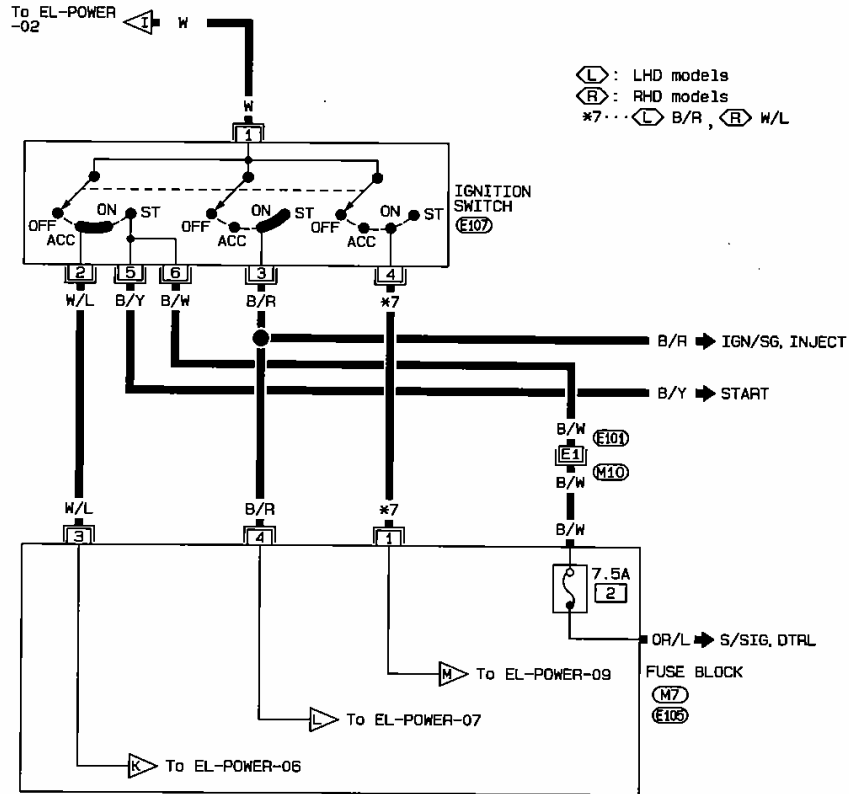

Refer to last page (Foldout page).

(M10), (E101)

EL

POWER SUPPLY ROUTING

Wiring Diagram — POWER — (Cont'd)

EL-POWER-05

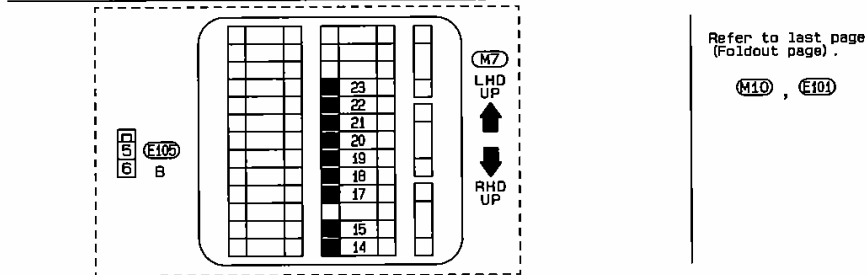
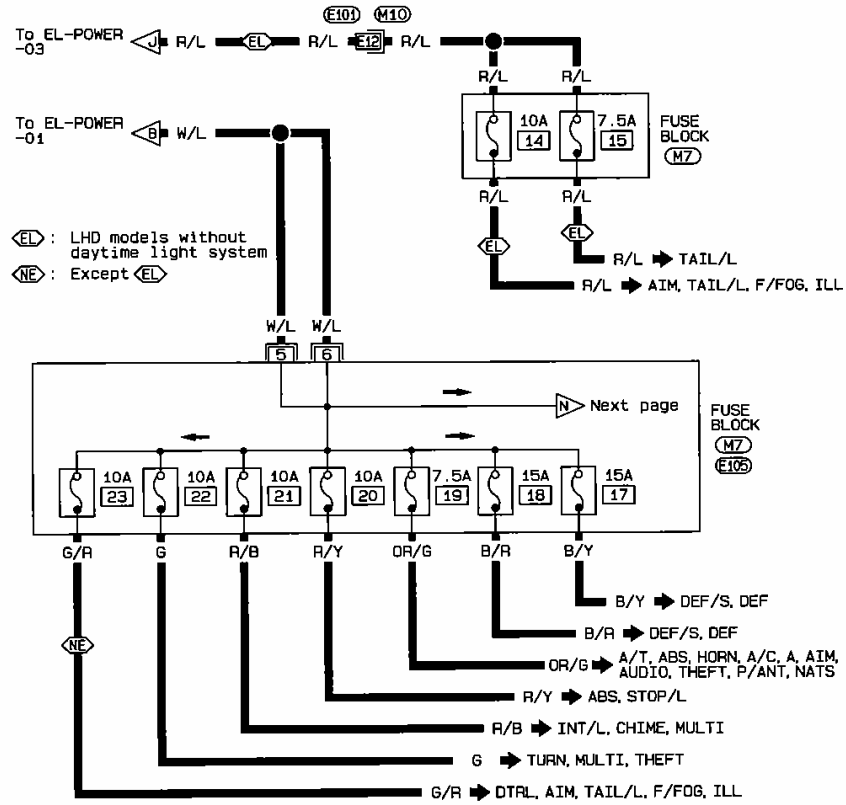

POWER SUPPLY ROUTING

Wiring Diagram — POWER — (Cont'd)

EL-POWER-06

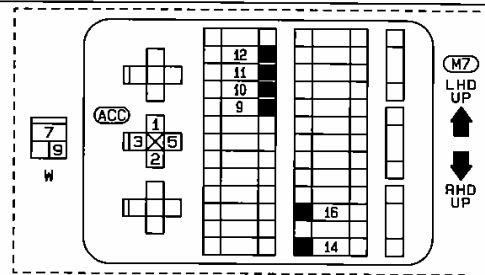
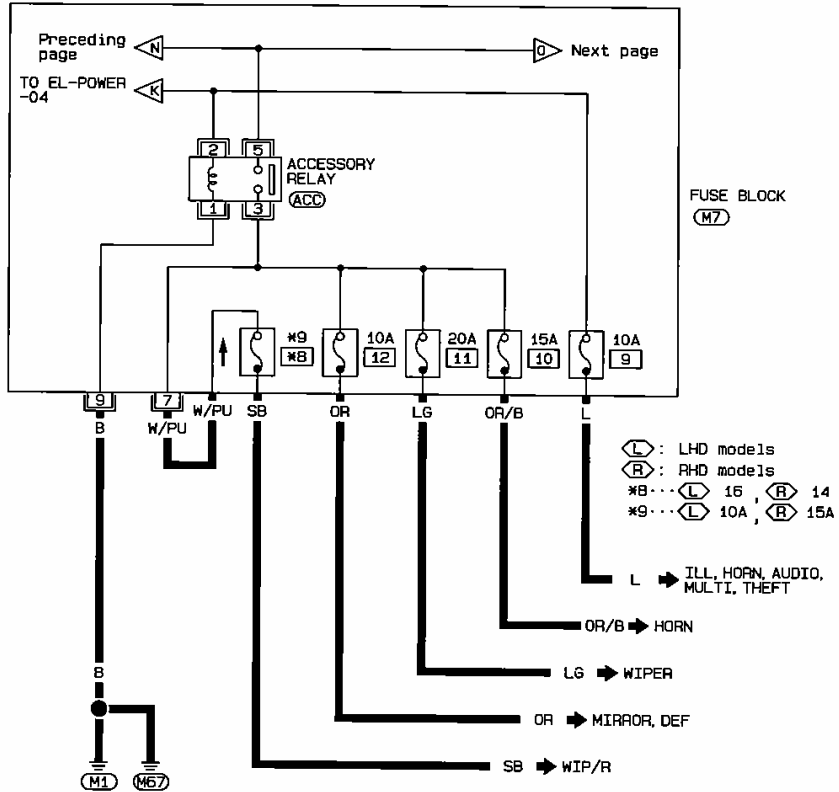

EL

POWER SUPPLY ROUTING

Wiring Diagram — POWER — (Cont'd)

EL-POWER-07

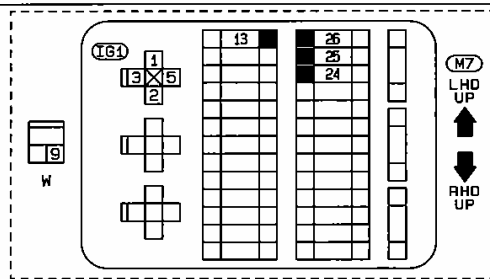
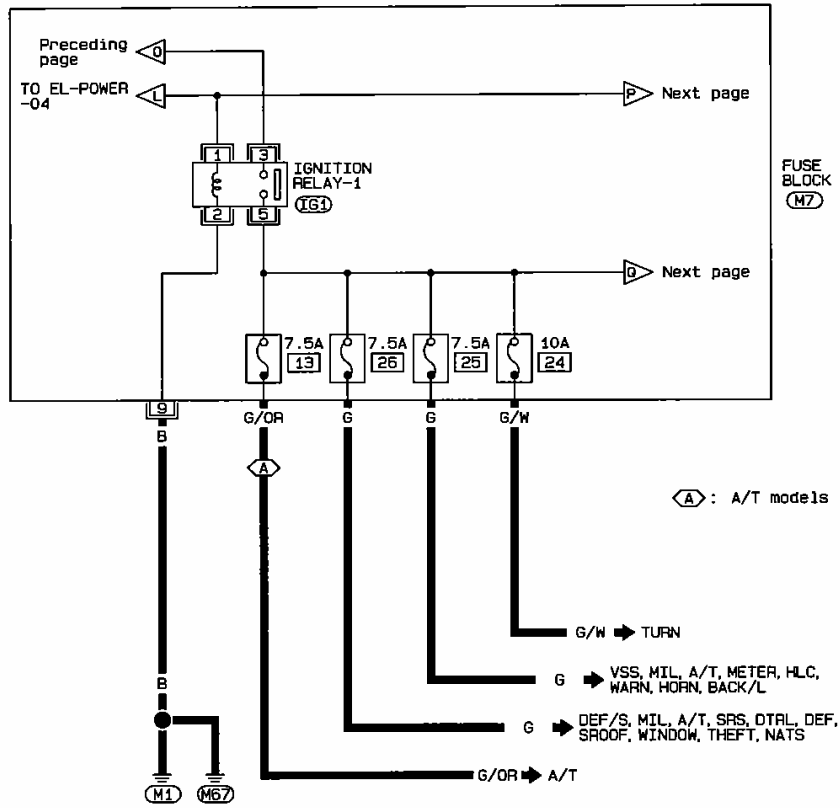

EL-12

HEL216

POWER SUPPLY ROUTING

Wiring Diagram — POWER — (Cont'd)

EL-POWER-08

- (L) : LHD models
- (R) : RHD models
- (EU) : For Europe
- *10... (L) 29, (R) 28
- *11... (L) R/L, (R) L

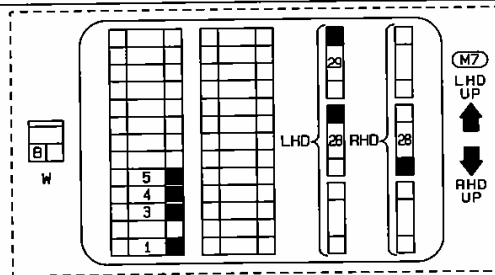
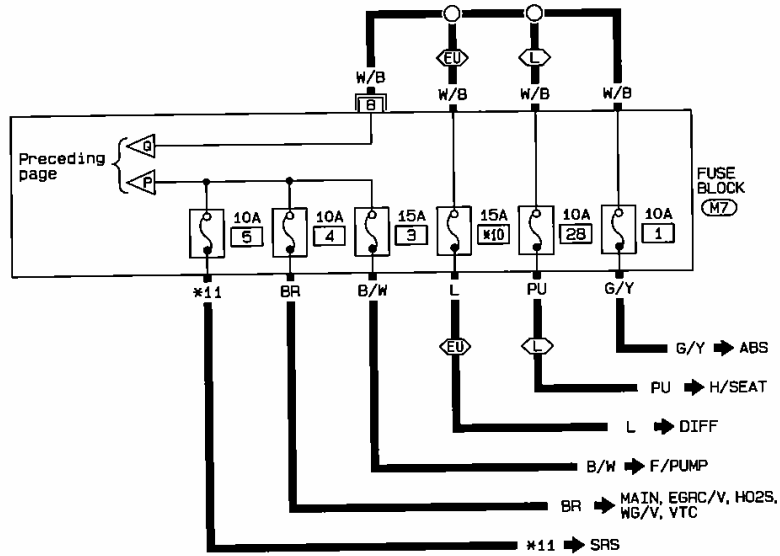

EL

SEL675T

POWER SUPPLY ROUTING

Wiring Diagram — POWER — (Cont'd)

EL-POWER-09

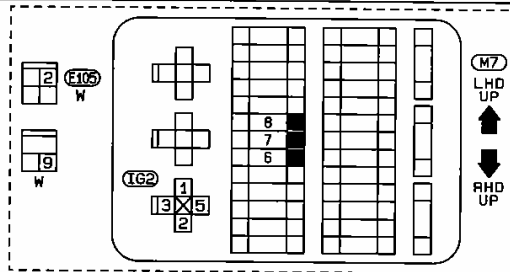
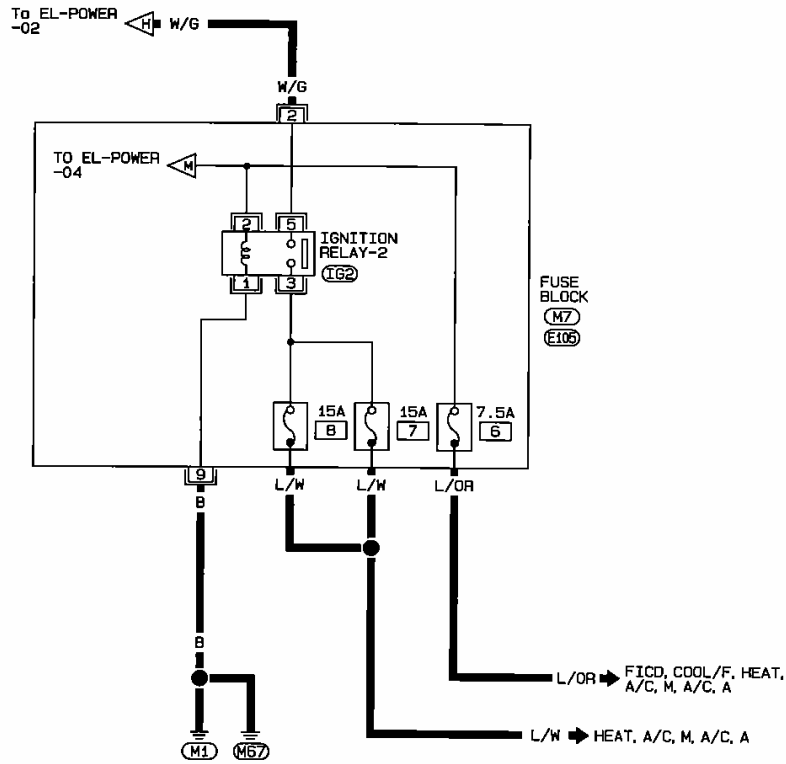

BATTERY

Service Data and Specifications (SDS)

Applied model	For Europe and Australia	Except for Europe and Australia	Optional on LHD models for Europe
Type	55D23R	65D26R	80D26R
Capacity V-AH	12 - 60	12 - 65	12 - 65

EL

STARTING SYSTEM

Construction

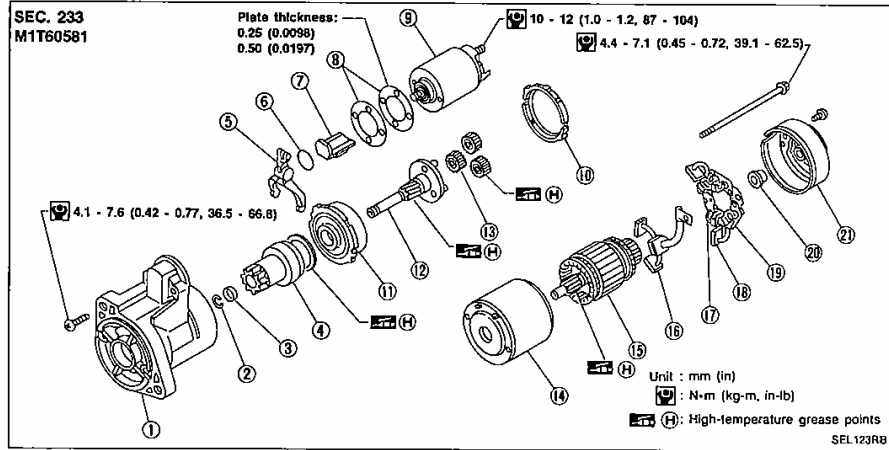

- ① Gear case
- ② Stopper clip
- ③ Pinion stopper
- ④ Pinion assembly
- ⑤ Shift lever
- ⑥ Plate
- ⑦ Packing

- ⑧ Adjusting plate
- ⑨ Magnetic switch assembly
- ⑩ Packing
- ⑪ Internal gear
- ⑫ Shaft
- ⑬ Planetary gear
- ⑭ Yoke

- ⑮ Armature
- ⑯ Brush (+)
- ⑰ Brush spring
- ⑱ Brush (-)
- ⑲ Brush holder
- ⑳ Bearing
- ㉑ Rear cover

Service Data and Specifications (SDS)

STARTER MOTOR

Type	M1T60581	
	Reduction gear type	
	MITSUBISHI	
System voltage	V	12
No load		
Terminal voltage	V	11.0
Current	A	50 - 75
Revolution	rpm	3,000 - 4,000
Minimum diameter of commutator	mm (in)	28.8 (1.134)
Minimum length of brush	mm (in)	12.0 (0.472)
Brush spring tension	N (kg, lb)	13.7 - 25.5 (1.4 - 2.6, 3.1 - 5.7)
Movement "E" in height of pinion assembly	mm (in)	0.5 - 2.0 (0.020 - 0.079)

EXTERIOR LAMP

Front Fog Lamp/Wiring Diagram — F/FOG —
LHD MODELS WITH DAYTIME LIGHT SYSTEM

EL-F/FOG-01

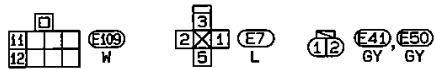
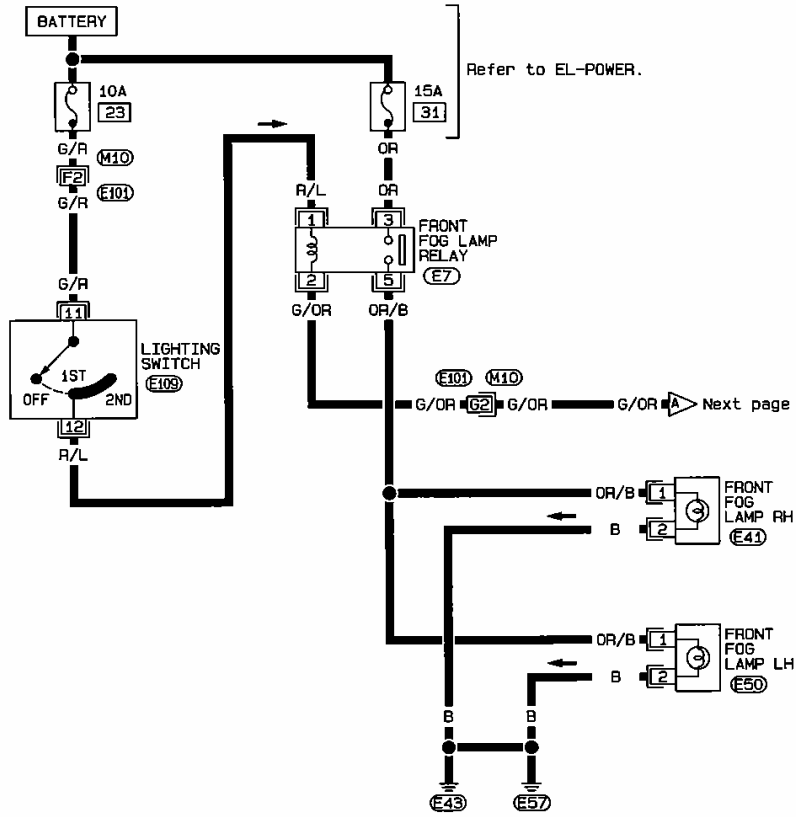

Refer to last page
(Foldout page).

(M10), (E101)

EL

HEL217

EXTERIOR LAMP

**Front Fog Lamp/Wiring Diagram — F/FOG —
(Cont'd)**

EL-F/FOG-02

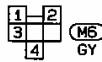
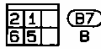
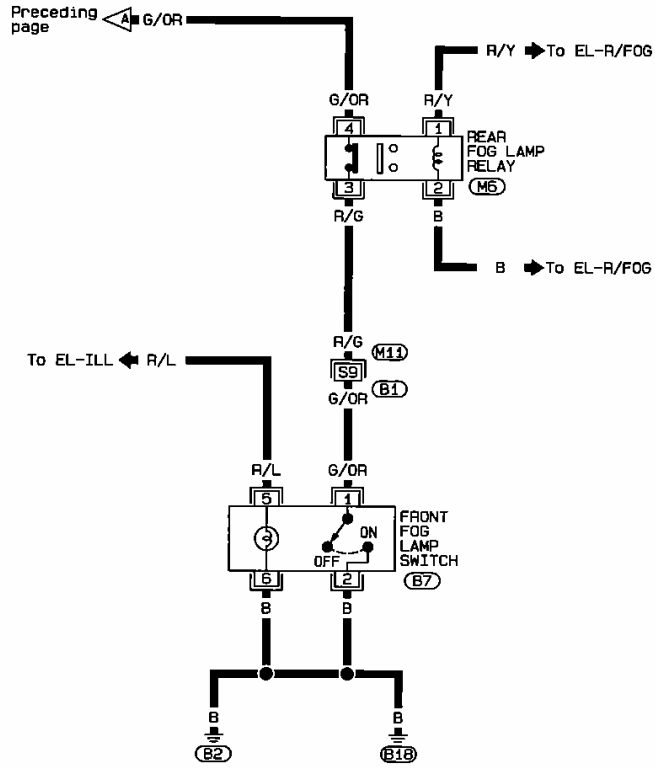

Refer to last page
(Foldout page).

(M11), (B1)

SEL699T

EXTERIOR LAMP

Rear Fog Lamp/Wiring Diagram — R/FOG —

WITH DAYTIME LIGHT SYSTEM

EL-R/FOG-01

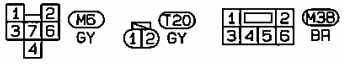
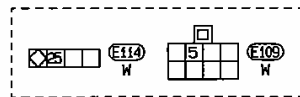
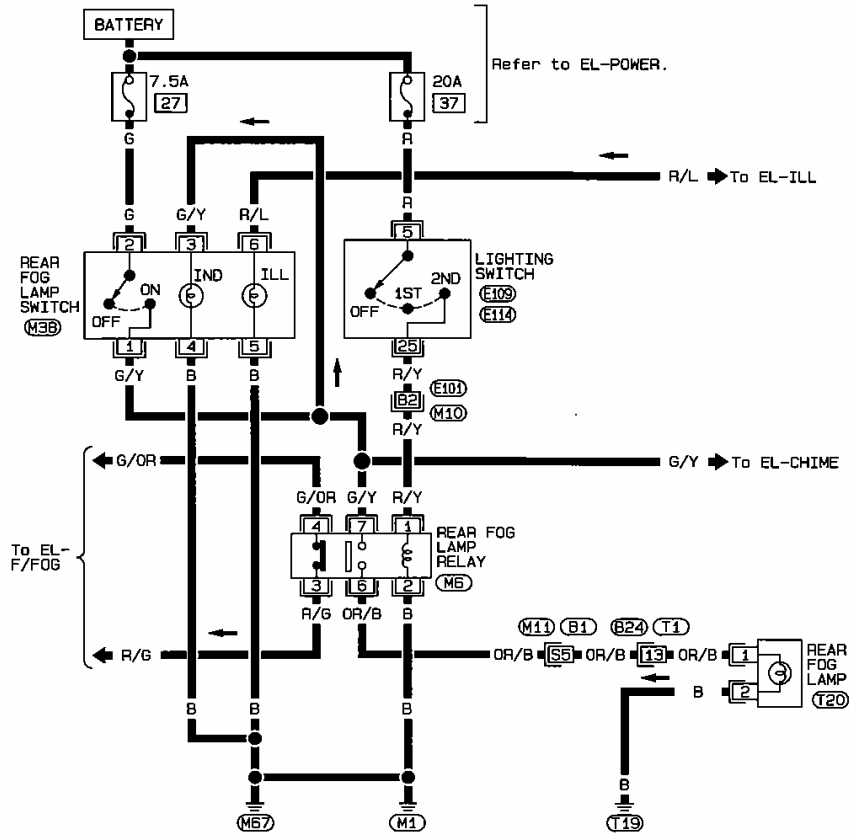

Refer to last page (Foldout page).

- (M10), (E101)
- (M11), (B1)

EL

EXTERIOR LAMP

Rear Fog Lamp/Wiring Diagram — R/FOG — (Cont'd)

WITHOUT DAYTIME LIGHT SYSTEM

EL-R/FOG-02

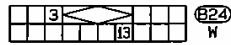
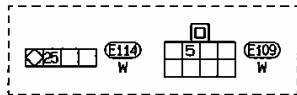
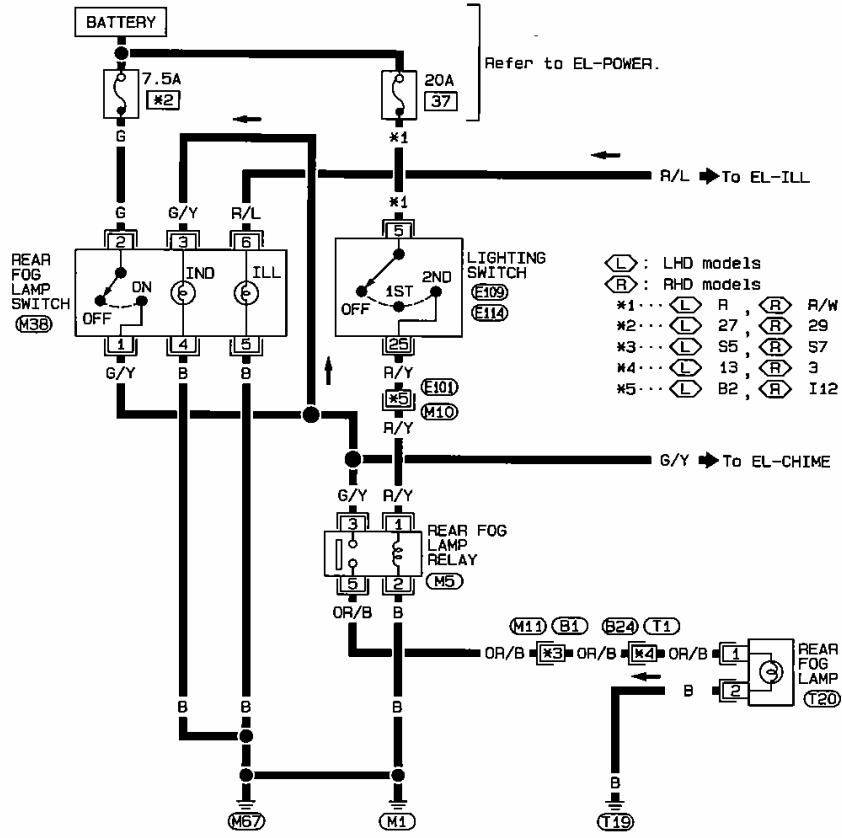

Refer to last page
(Foldout page).

M10, E101
M11, B1

EXTERIOR LAMP

Turn Signal and Hazard Warning Lamps/ Schematic

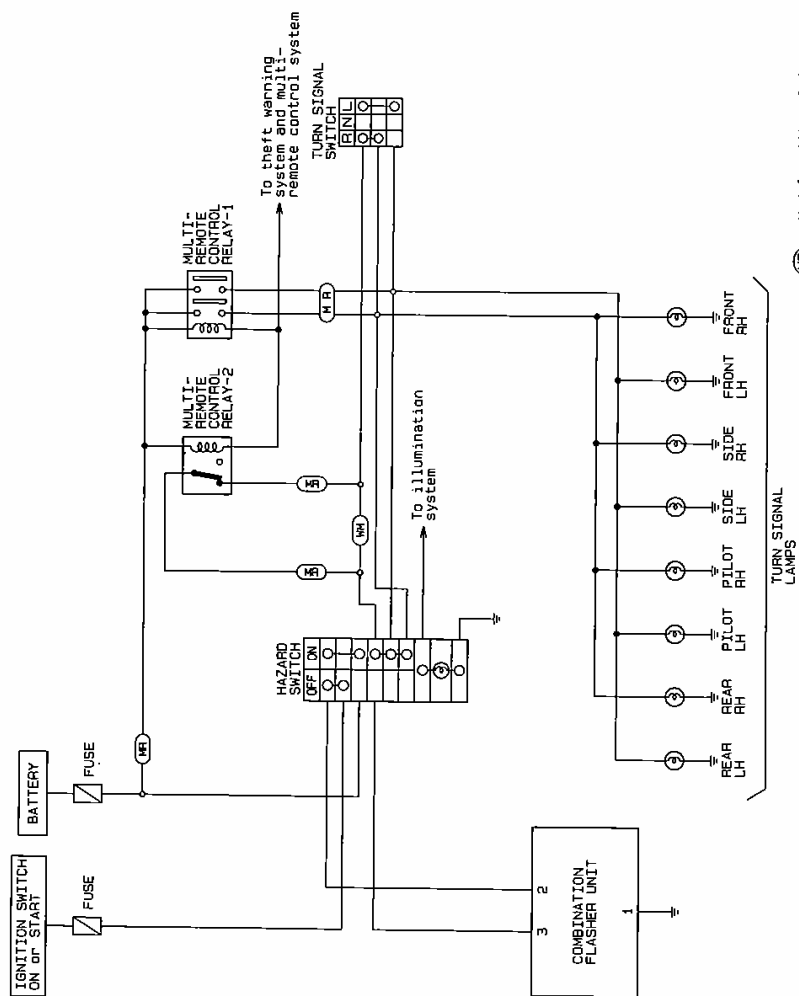

EXTERIOR LAMP

Turn Signal and Hazard Warning Lamps/Wiring Diagram — TURN —

LHD MODELS

EL-TURN-01

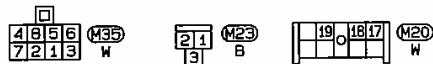
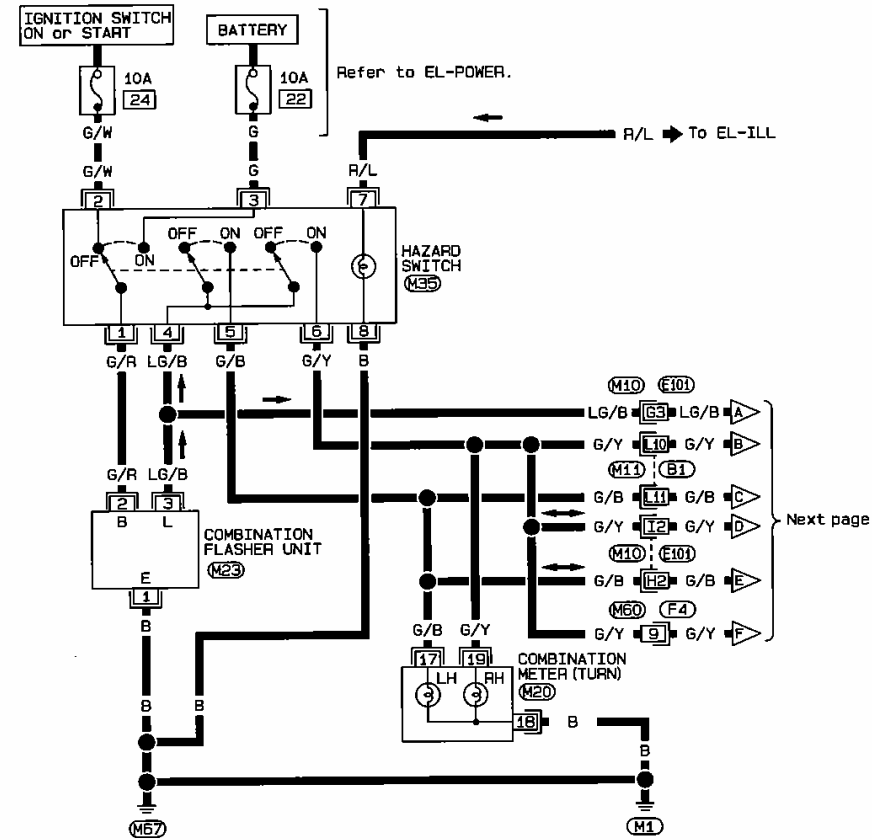

Refer to last page (Foldout page).

- (M10), (E101)
- (M11), (B1)
- (M60), (F4)

HEL221

EXTERIOR LAMP

Turn Signal and Hazard Warning Lamps/Wiring Diagram — TURN — (Cont'd)

EL-TURN-02

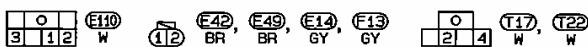
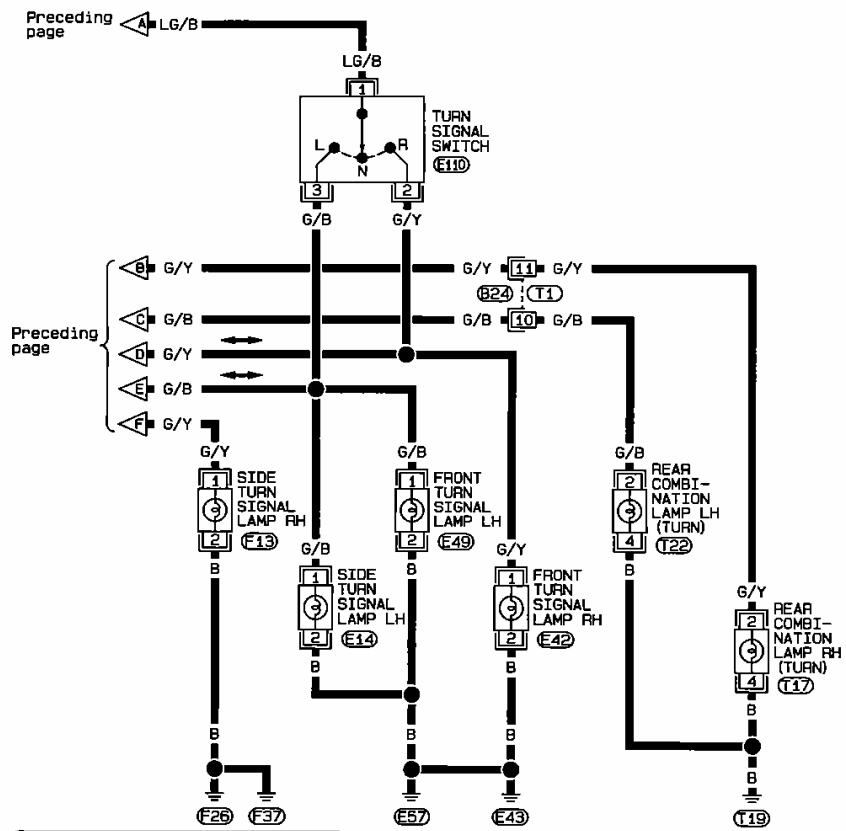

EL

SEL707T

EXTERIOR LAMP

Turn Signal and Hazard Warning Lamps/Wiring Diagram — TURN — (Cont'd)

RHD MODELS

EL-TURN-03

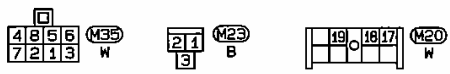
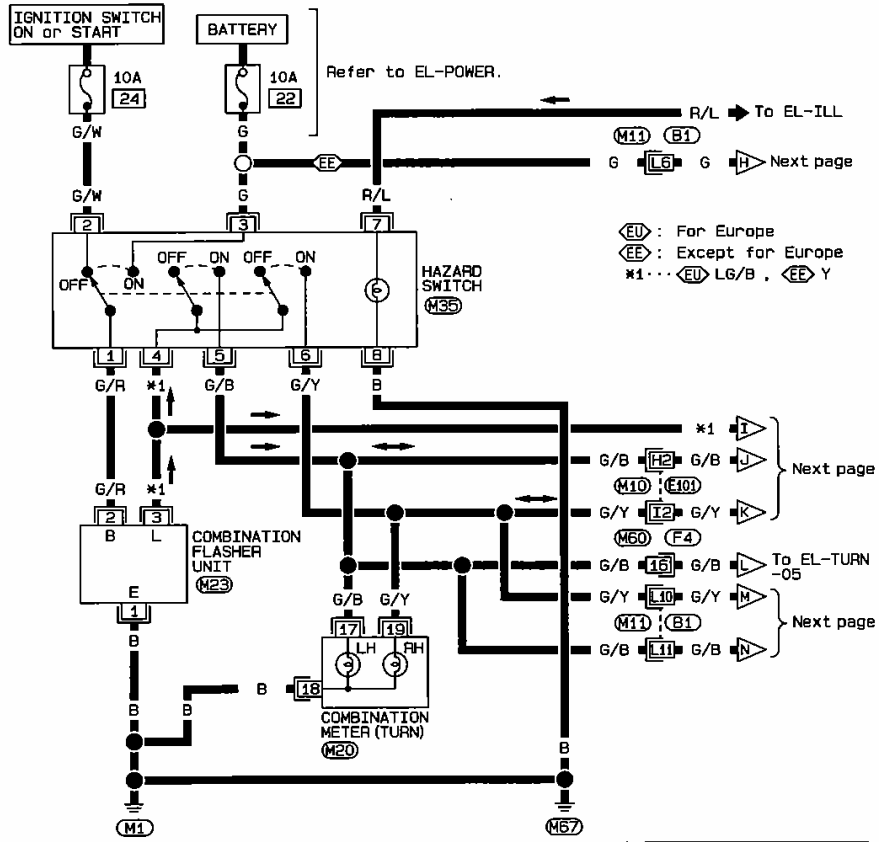

Refer to last page (Foldout page).

(M10, E10)
 (M11, B1)
 (M60, F4)

EXTERIOR LAMP

Turn Signal and Hazard Warning Lamps/Wiring Diagram — TURN — (Cont'd)

EL-TURN-04

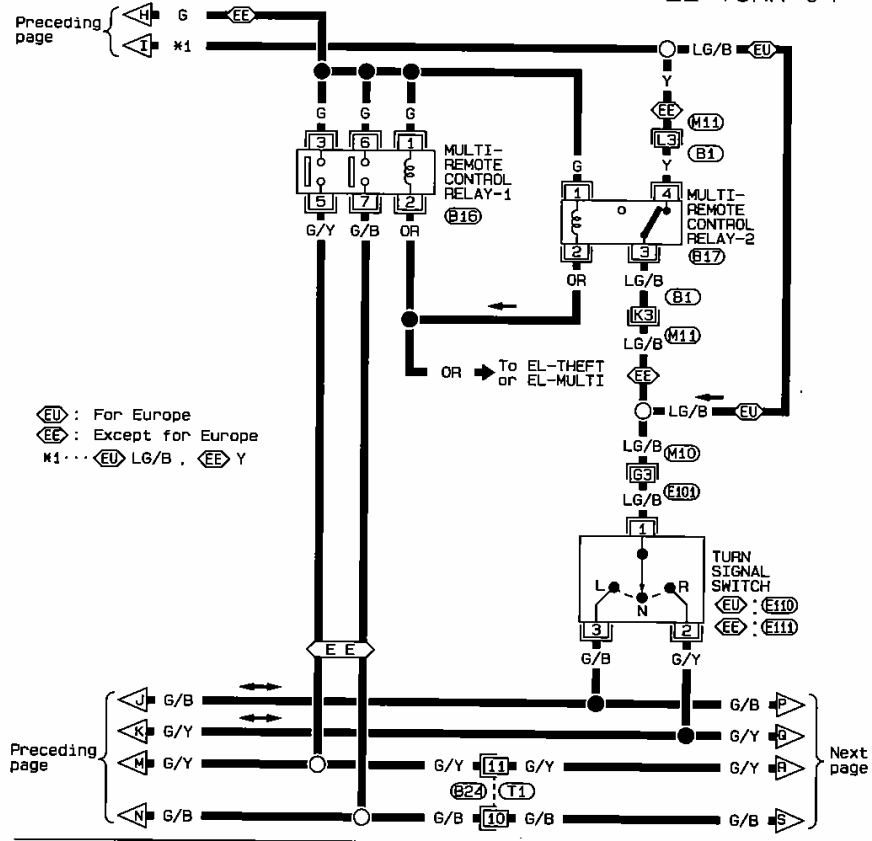

(EU) : For Europe
 (EE) : Except for Europe
 *1... (EU) LG/B, (EE) Y

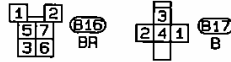
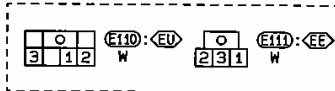

Refer to last page (Foldout page).

(M10), (E100)
 (M11), (B1)



EL

EXTERIOR LAMP

Turn Signal and Hazard Warning Lamps/Wiring Diagram — TURN — (Cont'd)

EL-TURN-05

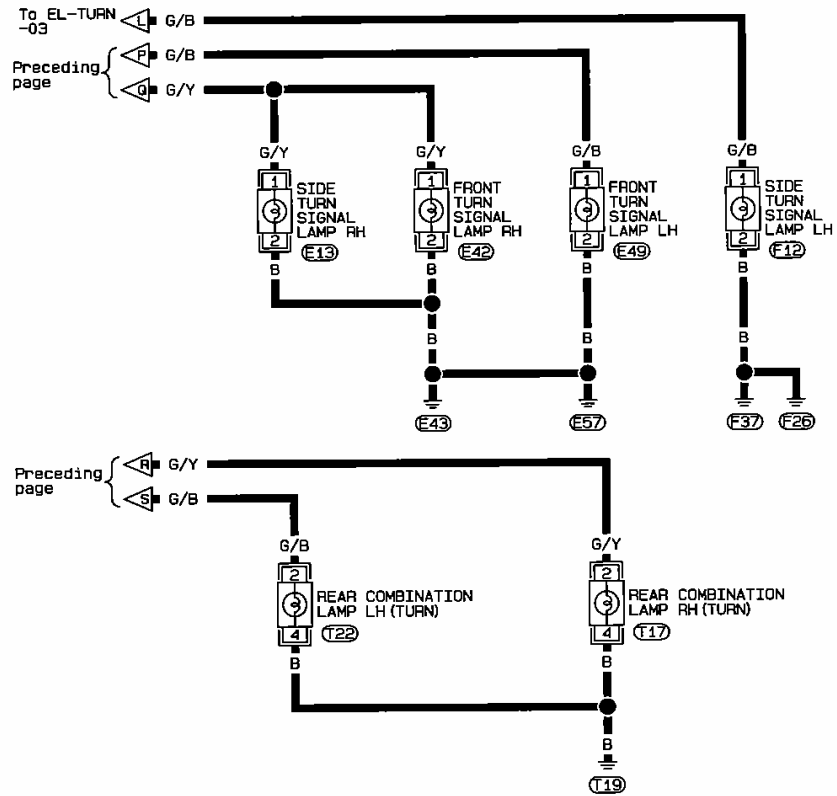

INTERIOR LAMP

Illumination/Schematic

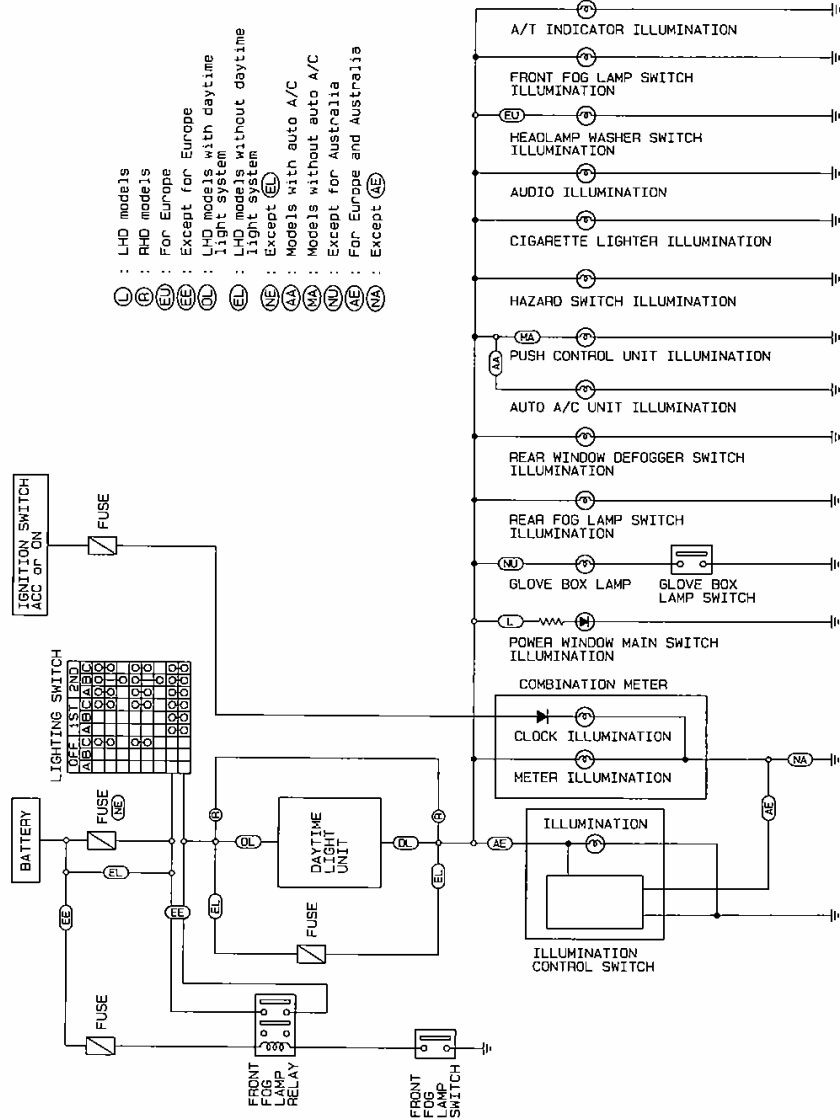

EL

INTERIOR LAMP

Illumination/Wiring Diagram — ILL —

EL-ILL-01

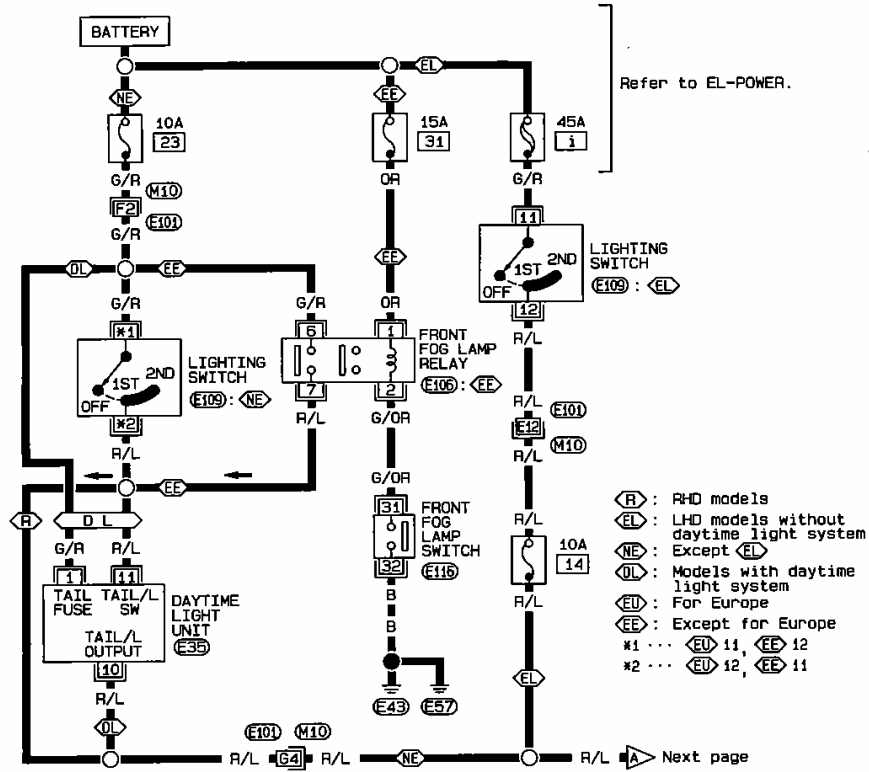

- (R) : RHD models
- (EL) : LHD models without daytime light system
- (NE) : Except (EL)
- (DL) : Models with daytime light system
- (EU) : For Europe
- (EE) : Except for Europe
- *1 ... (EU) 11, (EE) 12
- *2 ... (EU) 12, (EE) 11

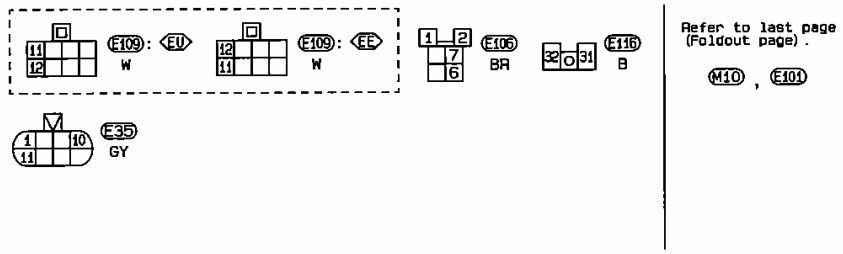

INTERIOR LAMP

Illumination/Wiring Diagram — ILL — (Cont'd)

EL-ILL-02

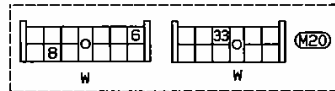
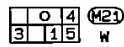
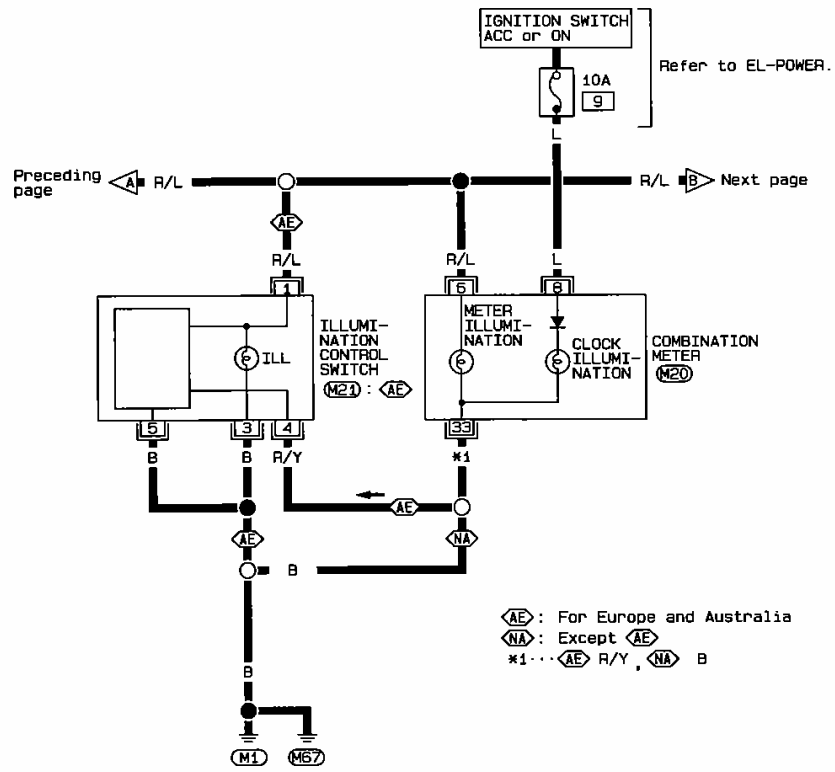

EL

SEL713T

INTERIOR LAMP

Illumination/Wiring Diagram — ILL — (Cont'd)

EL-ILL-03

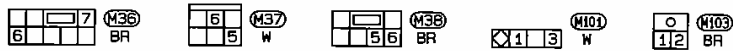
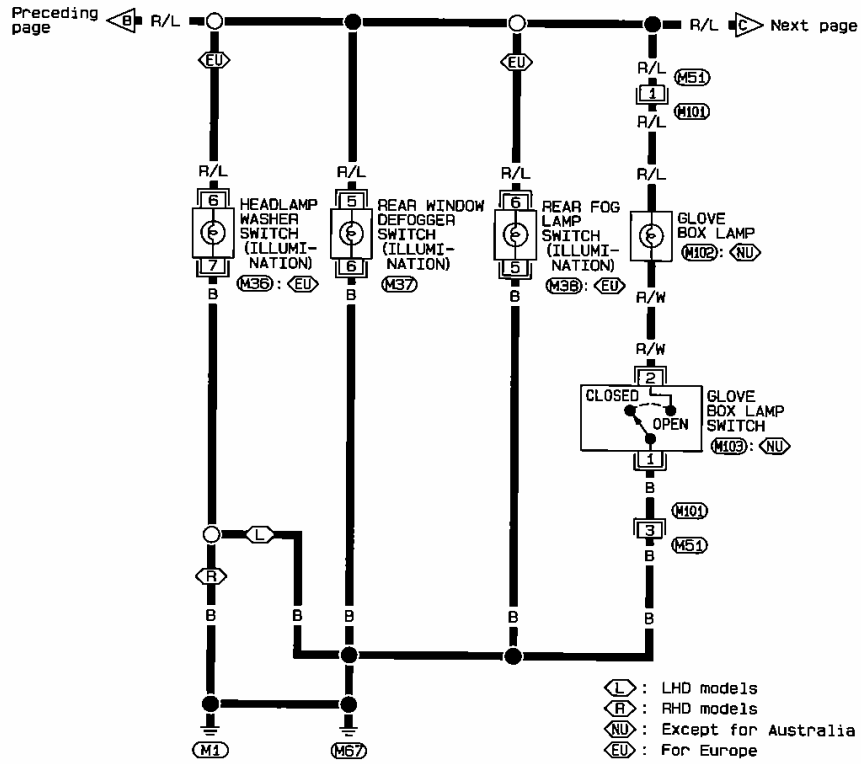

INTERIOR LAMP

Illumination/Wiring Diagram — ILL — (Cont'd)

EL-ILL-04

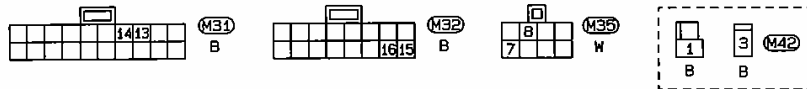
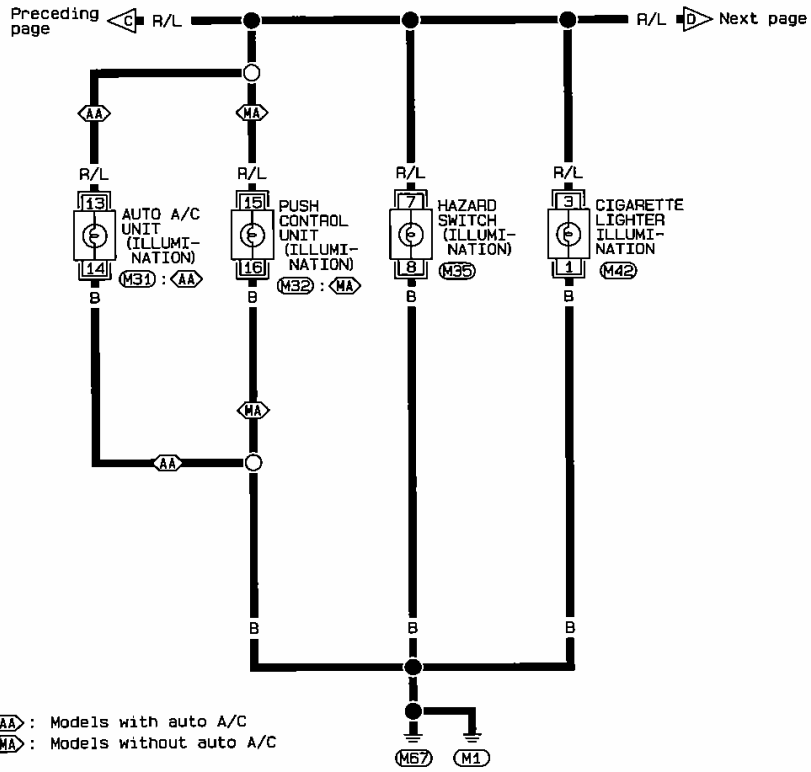

EL

INTERIOR LAMP

Illumination/Wiring Diagram — ILL — (Cont'd)

EL-ILL-05

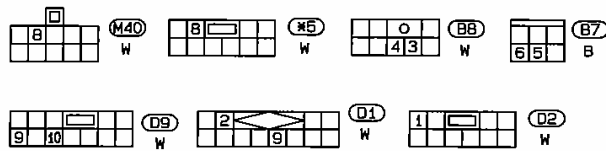
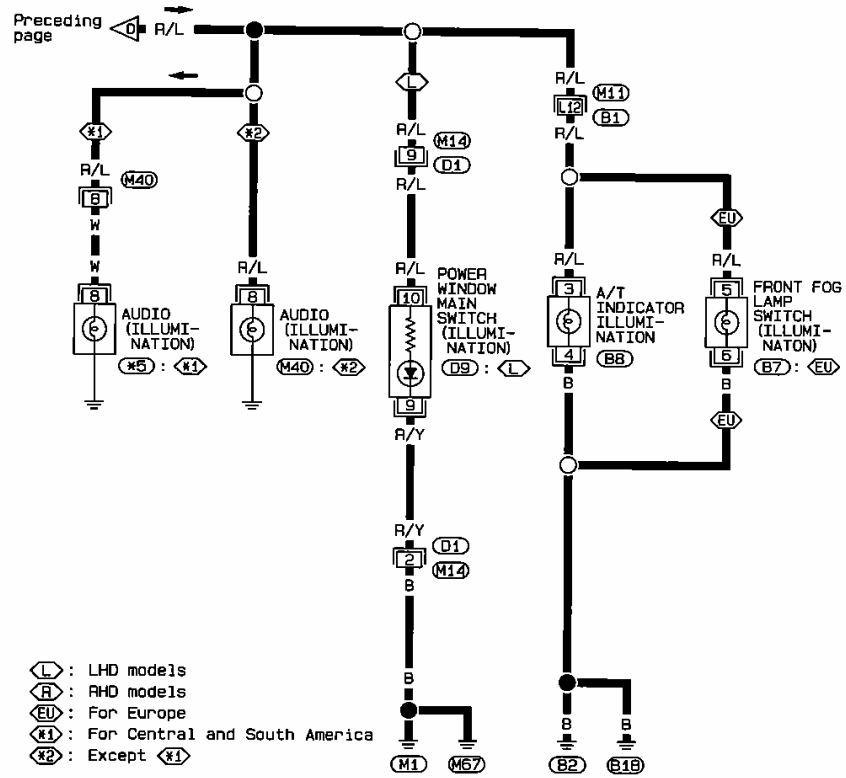

Refer to last page (Foldout page).

M11, B1

INTERIOR LAMP

Interior, Spot and Trunk Room Lamps/Wiring Diagram — INT/L —

LHD MODELS

EL-INT/L-01

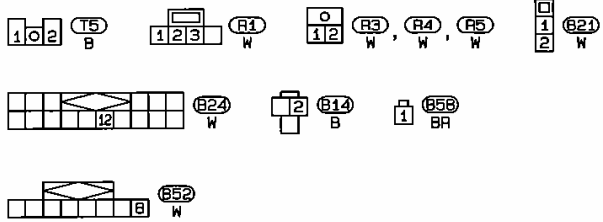
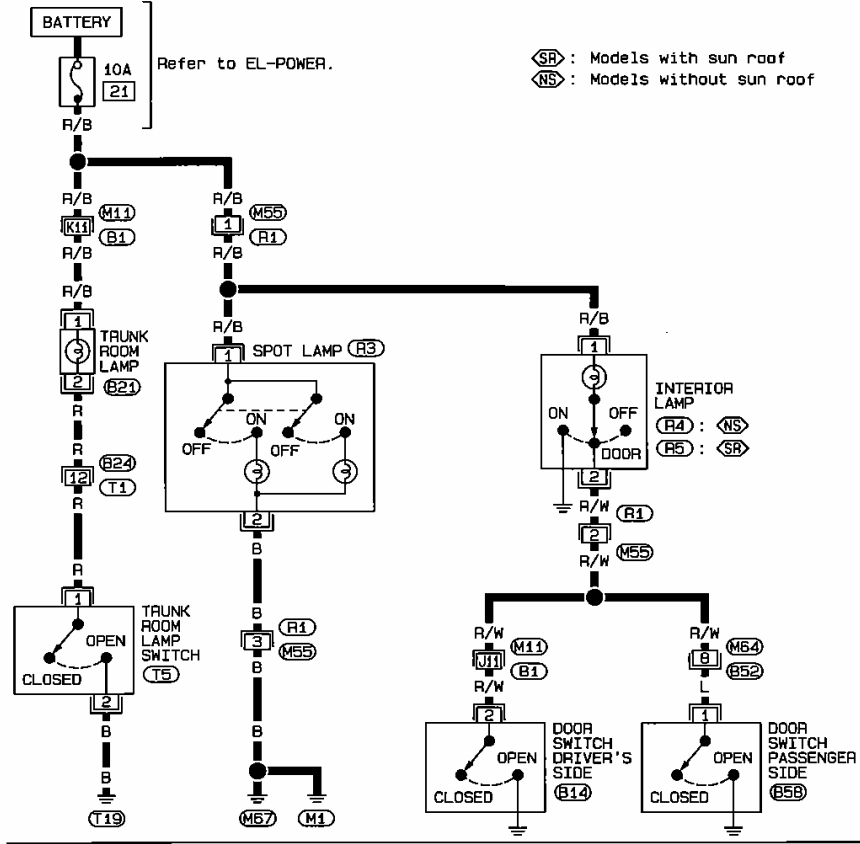

Refer to last page (Foldout page).

(M11), (B1)

EL

INTERIOR LAMP

Interior, Spot and Trunk Room Lamps/Wiring Diagram — INT/L — (Cont'd)

RHD MODELS

EL-INT/L-02

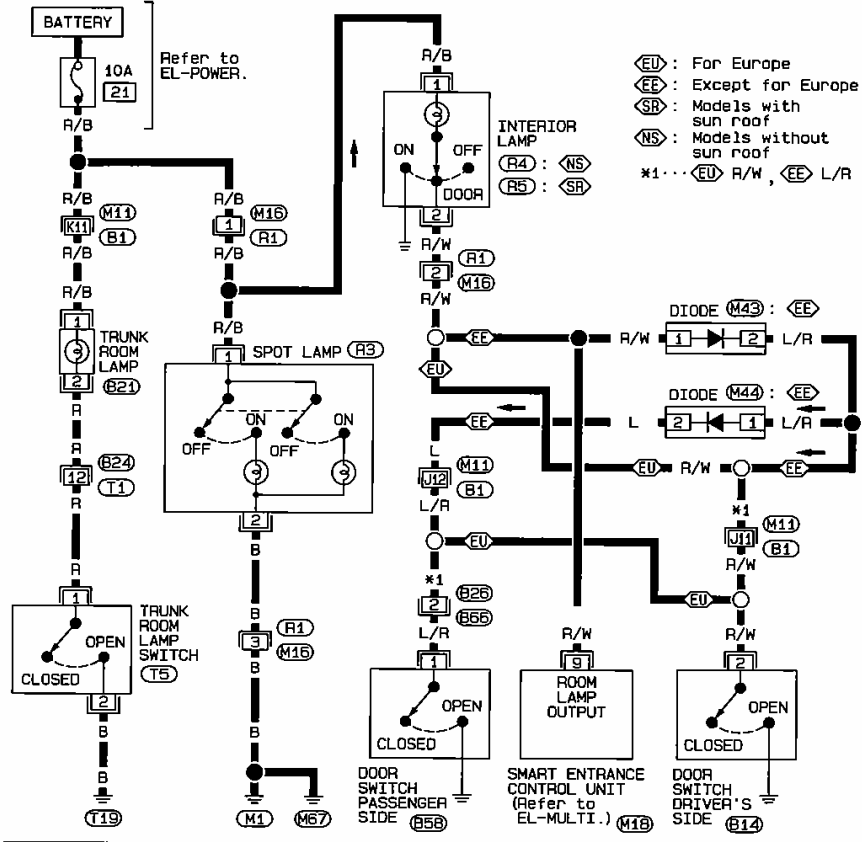

- ⓔⓤ : For Europe
- ⓔⓔ : Except for Europe
- ⓈⓇ : Models with sun roof
- ⓃⓈ : Models without sun roof
- *1...ⓔⓤ R/W, ⓔⓔ L/R

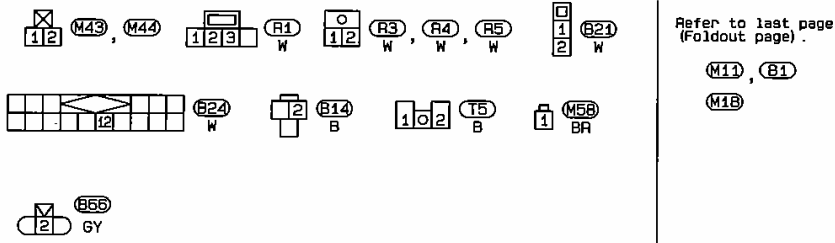

Refer to last page (Foldout page).

METER AND GAUGES

Combination Meter

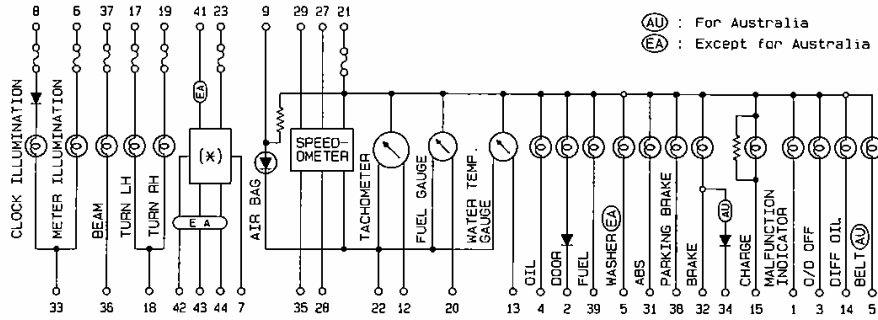
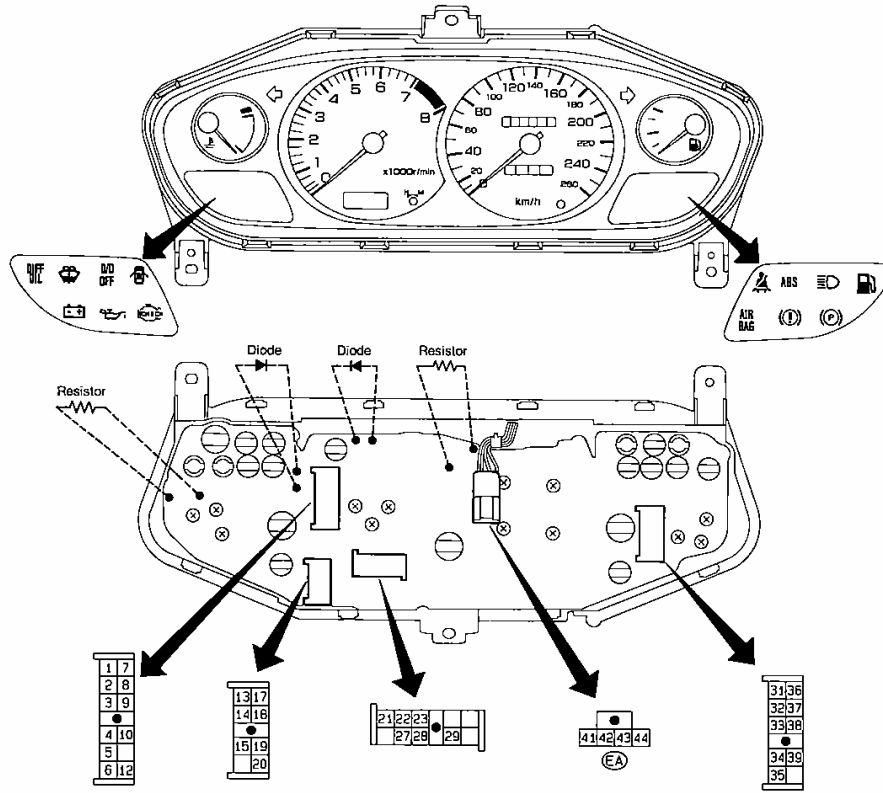

(X): Digital clock (AU)
 Digital clock and Ambient (Outside) temperature display (EA)



METER AND GAUGES

Speedometer, Tachometer, Temp. and Fuel Gauges/Wiring Diagram — METER —

EL-METER-01

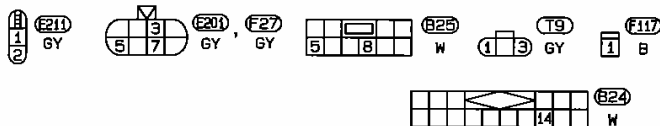
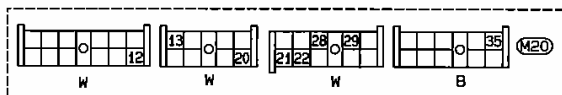
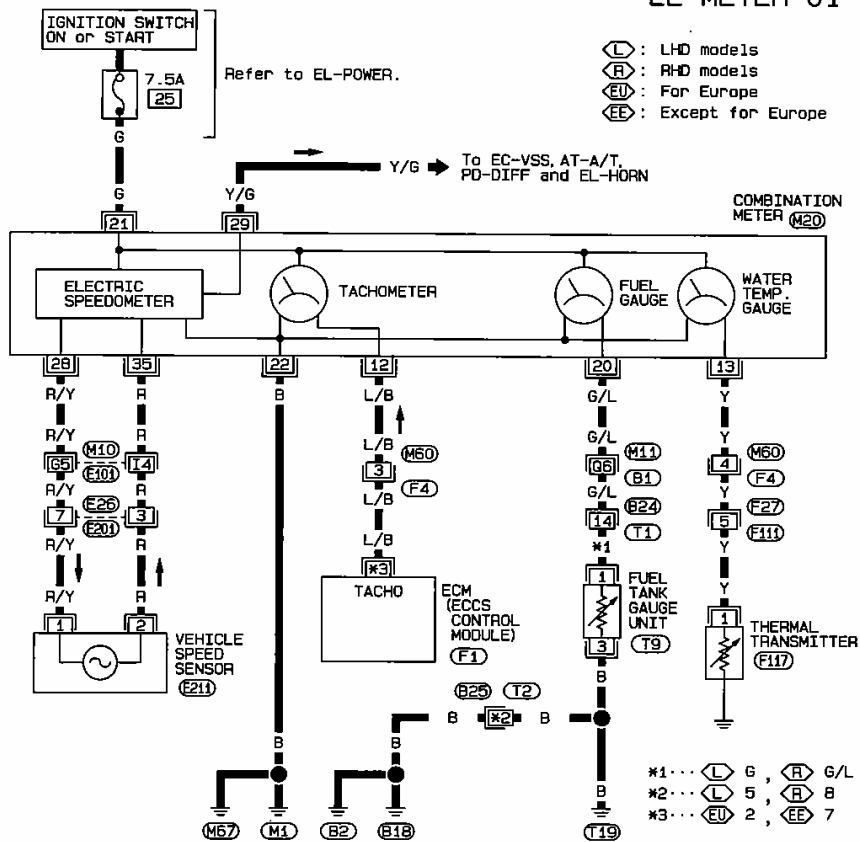

Refer to last page (Foldout page).

- (M10), (E10)
- (M11), (B1)
- (M20), (F4)
- (F1)

WARNING LAMPS AND BUZZER

Warning Lamps/Schematic

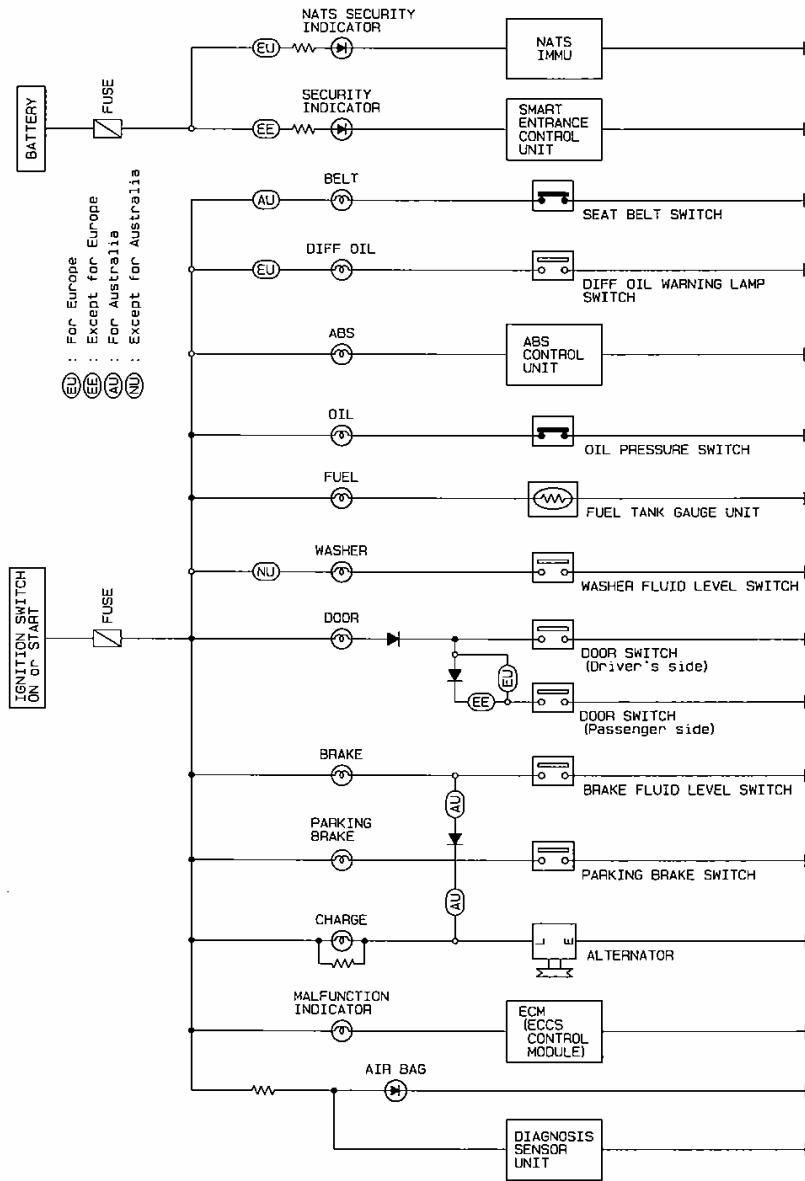

WARNING LAMPS AND BUZZER

Warning Lamps/Wiring Diagram — WARN —

LHD MODELS

EL-WARN-01

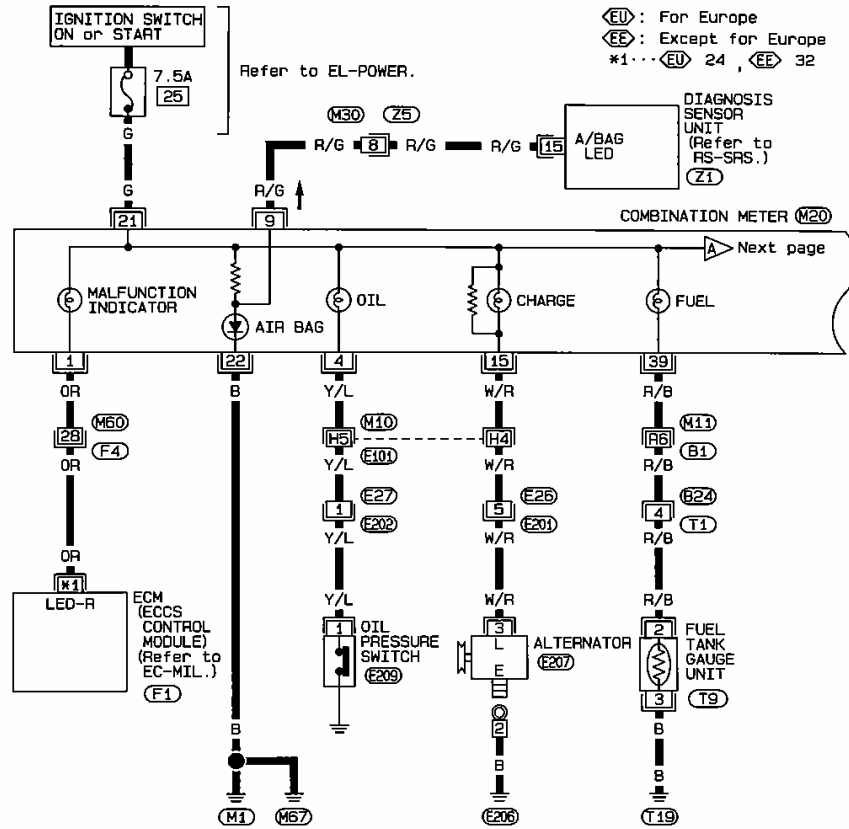

◁EU▷ : For Europe
 ◁EE▷ : Except for Europe
 *1...◁EU▷ 24 , ◁EE▷ 32

DIAGNOSIS SENSOR UNIT (Refer to RS-SRS.)
(Z1)

COMBINATION METER (M20)

Next page

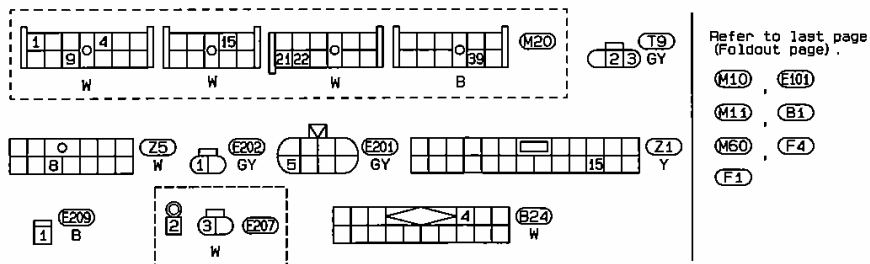

Refer to last page (Foldout page).

(M10) , (E101)
 (M11) , (B1)
 (M60) , (F4)
 (F1)

WARNING LAMPS AND BUZZER

**Warning Lamps/Wiring Diagram — WARN —
(Cont'd)**

EL-WARN-02

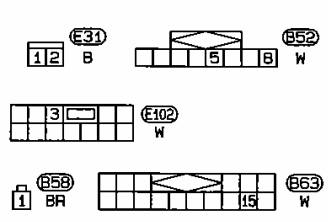
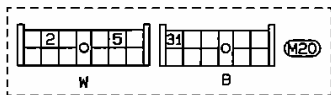
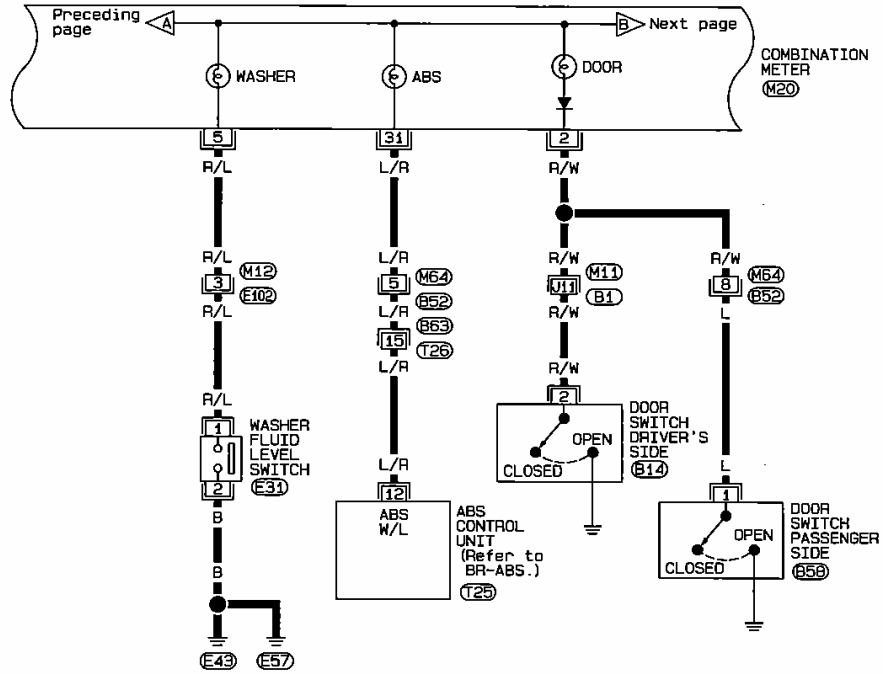

Refer to last page (Foldout page).
M11, B1

EL

WARNING LAMPS AND BUZZER

Warning Lamps/Wiring Diagram — WARN — (Cont'd)

EL-WARN-03

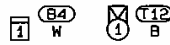
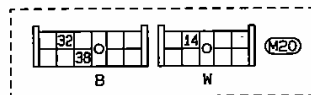
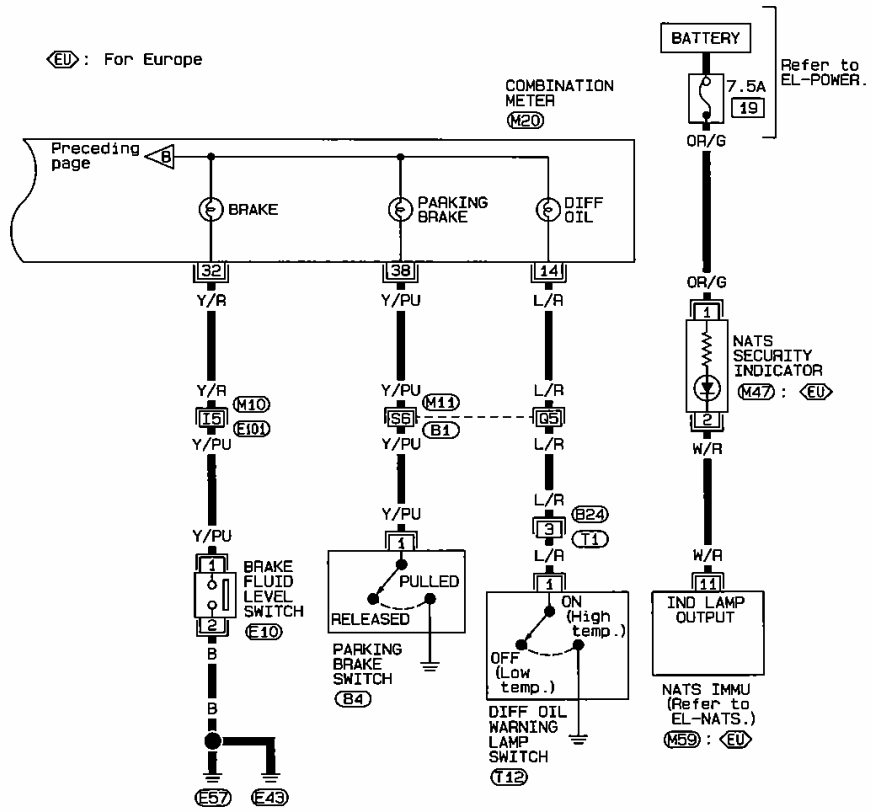

Refer to last page (Foldout page).

M10, E10
M11, B1



WARNING LAMPS AND BUZZER

Warning Lamps/Wiring Diagram — WARN —
(Cont'd)

RHD MODELS

EL-WARN-04

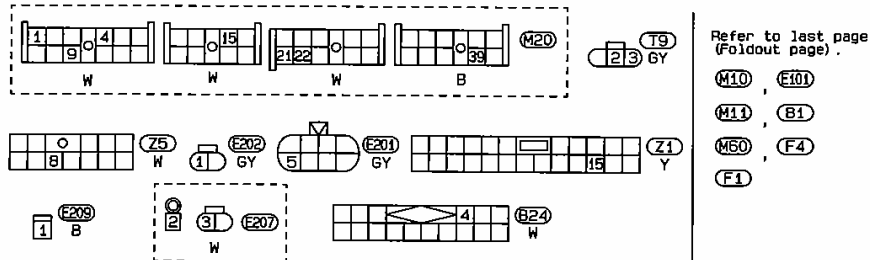
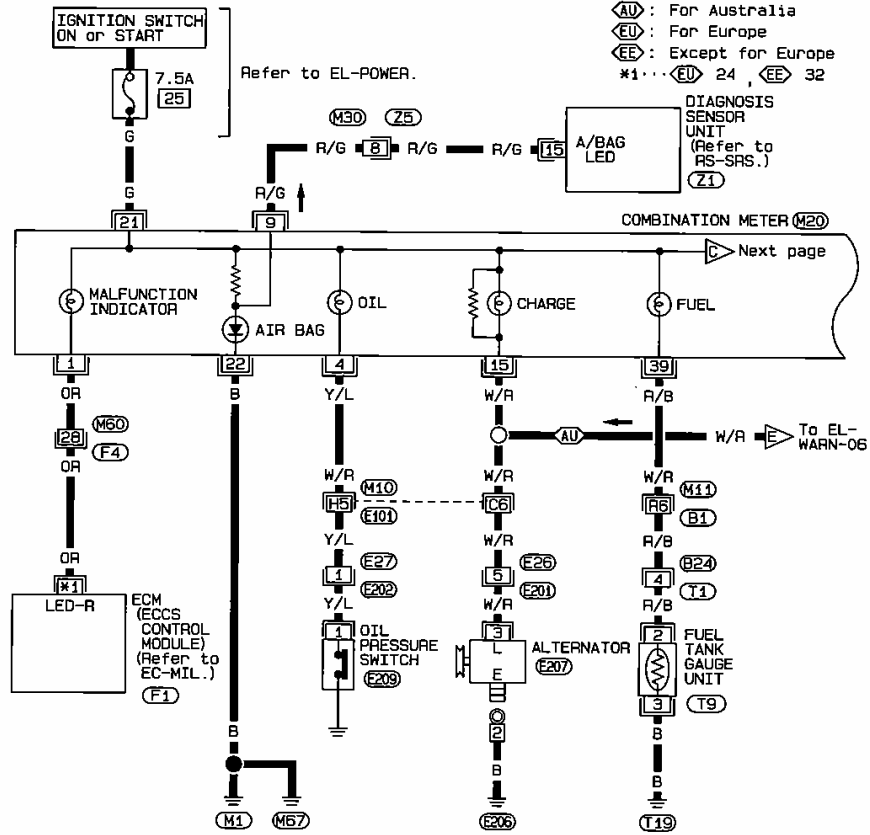

EL

HEL234

WARNING LAMPS AND BUZZER

**Warning Lamps/Wiring Diagram — WARN —
(Cont'd)**

EL-WARN-05

- ⊖(NU) : Except for Australia
- ⊖(EU) : For Europe
- ⊖(EE) : Except for Europe
- *2... ⊖(EU) R/W, ⊖(EE) L/R

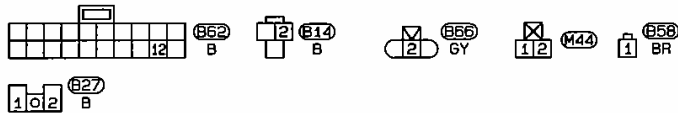
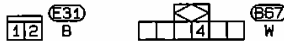
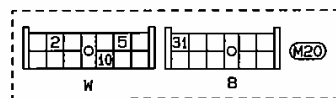
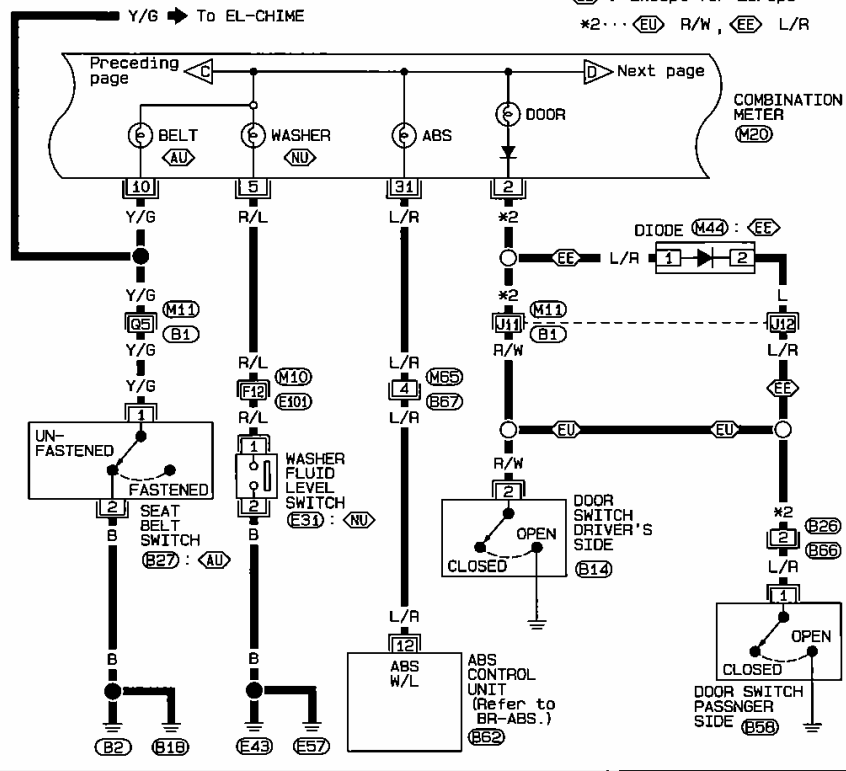

Refer to last page
(Foldout page).

- M10, E101
- M11, B1

HEL236

WARNING LAMPS AND BUZZER

Warning Lamps/Wiring Diagram — WARN — (Cont'd)

EL-WARN-06

- ⓔⓤ : For Europe
- ⓔⓔ : Except for Europe
- ⓔⓐ : For Australia

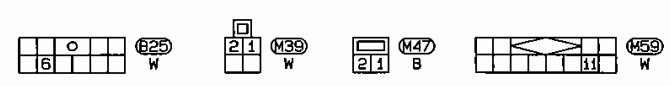
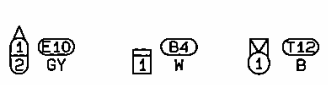
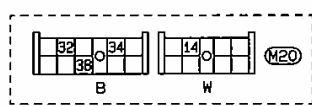
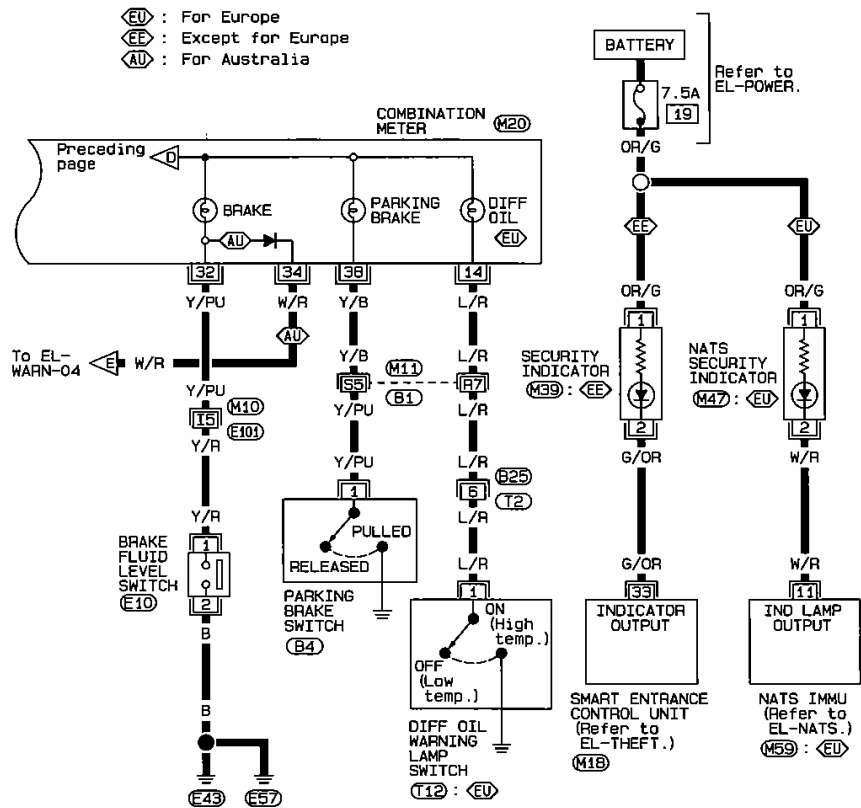

Refer to last page (Foldout page).
 M10, E10
 M11, B1
 M18

EL

WARNING LAMPS AND BUZZER

Warning Buzzer/Wiring Diagram — CHIME —

EL-CHIME-01

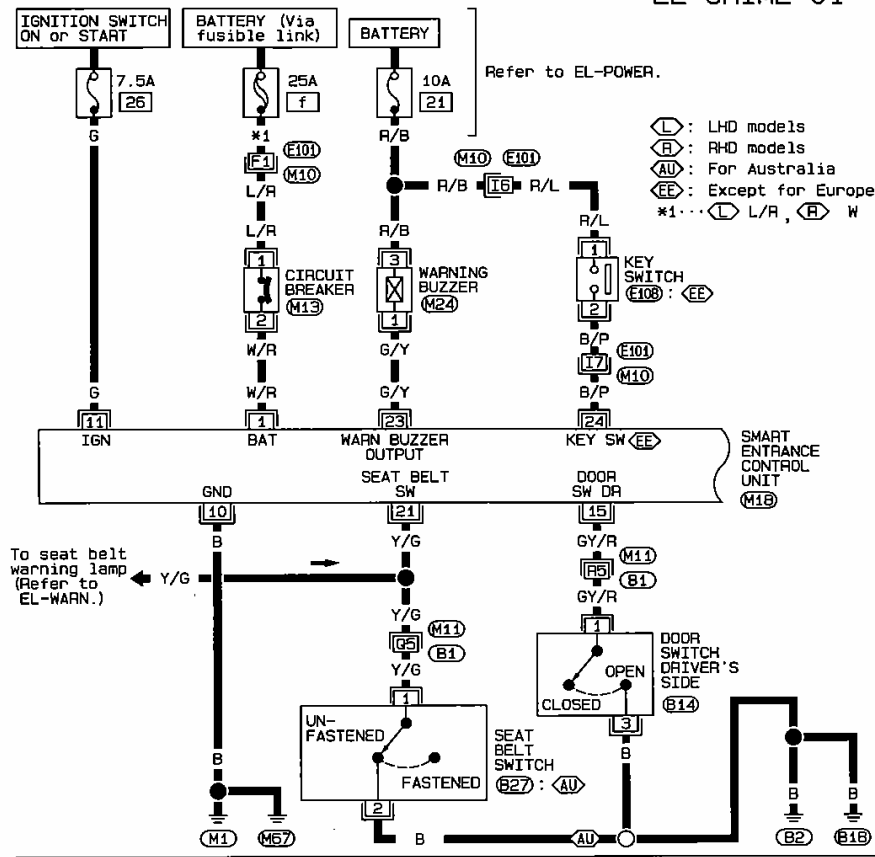

- (L) : LHD models
- (R) : RHD models
- (AU) : For Australia
- (EE) : Except for Europe
- *1... (L) L/R, (R) W



Refer to last page (Foldout page).

(M10), (E101)
 (M11), (B1)
 (M18)

WARNING LAMPS AND BUZZER

Warning Buzzer/Wiring Diagram — CHIME —
(Cont'd)

EL-CHIME-02

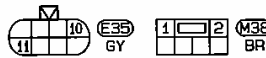
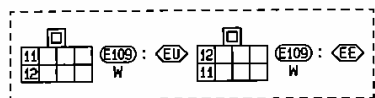
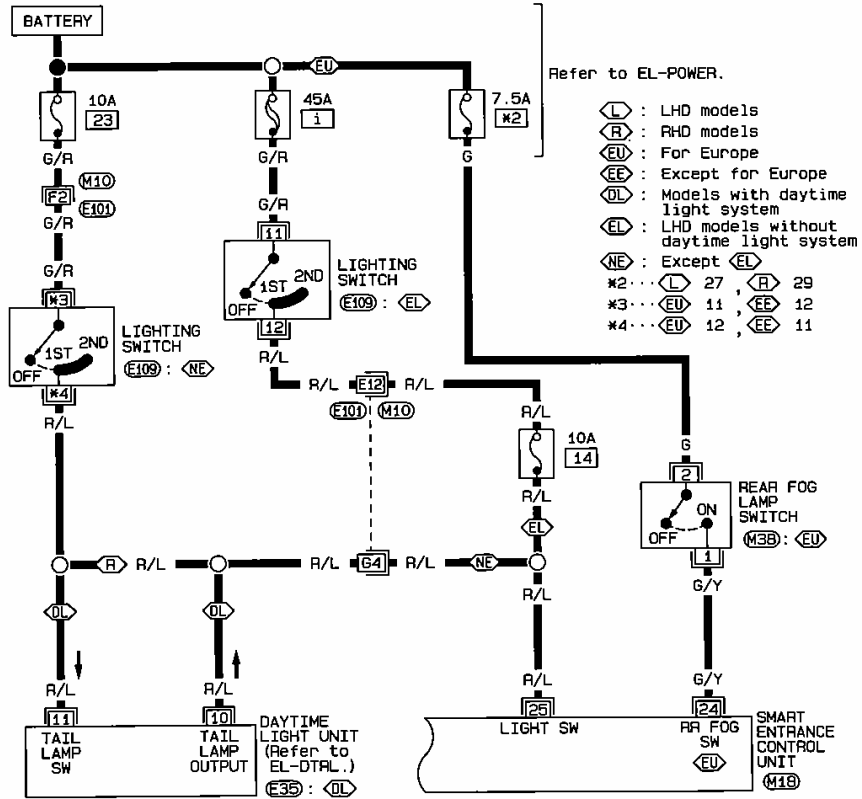

Refer to last page
(Foldout page).

M10, E101
M16

EL

HEL238

POWER WINDOW

Schematic

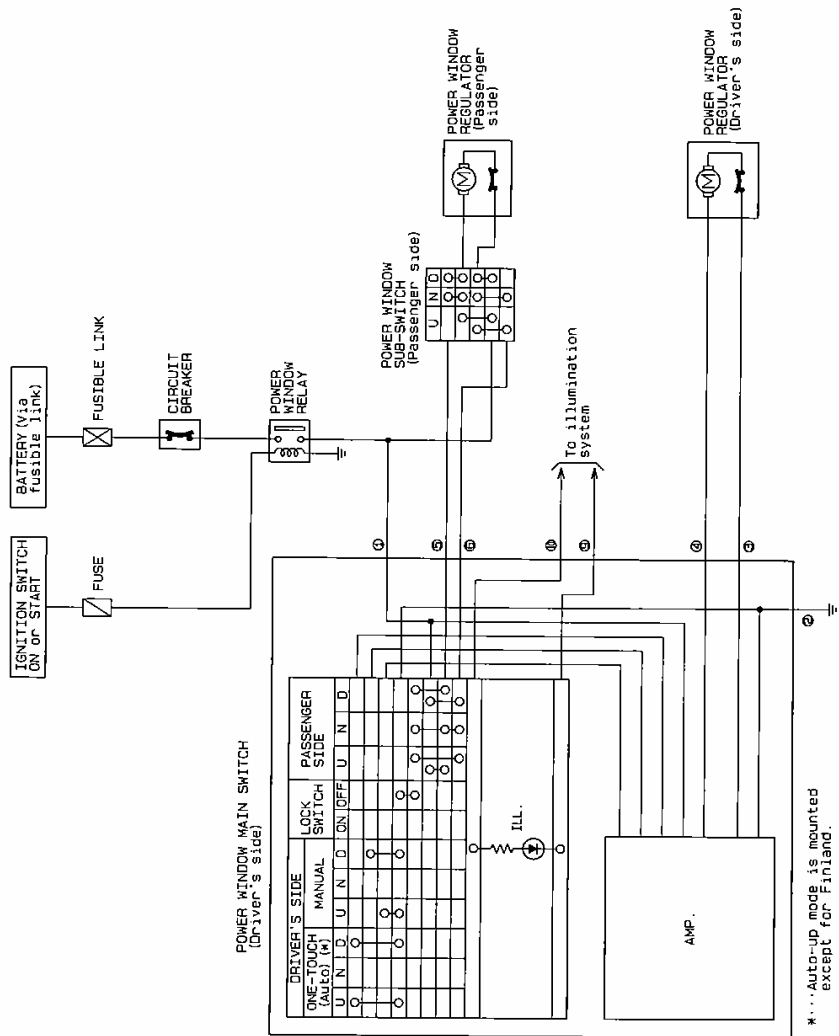

*...Auto-up mode is mounted except for Finland.

POWER WINDOW

Wiring Diagram — WINDOW —

EL-WINDOW-01

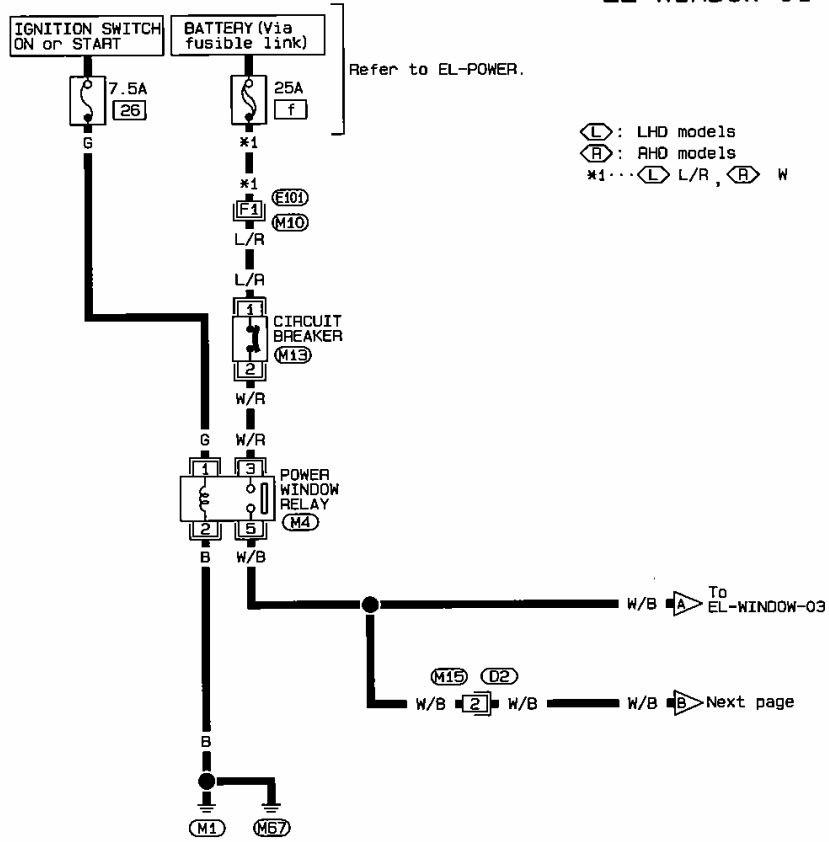

◁: LHD models
 ▷: RHD models
 *1...◁ L/R, ▷ W



Refer to last page (Foldout page).

M10, E101

EL

HEL240

POWER WINDOW

Wiring Diagram — WINDOW — (Cont'd)

EL-WINDOW-02

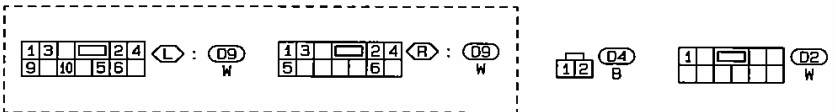
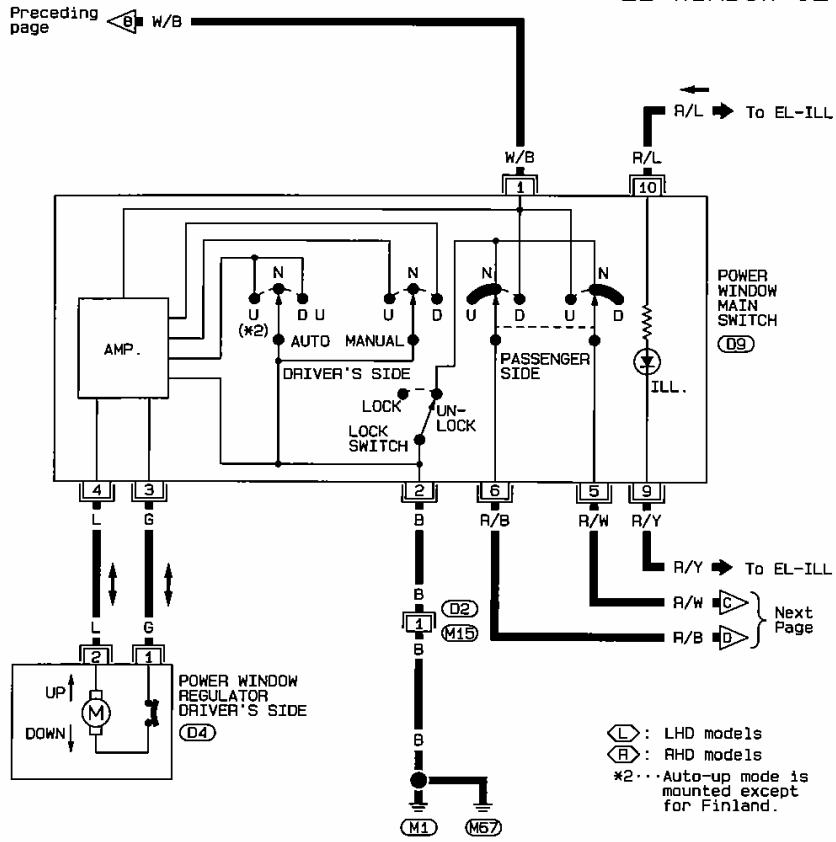

POWER WINDOW

Wiring Diagram --- WINDOW --- (Cont'd)

EL-WINDOW-03

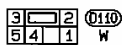
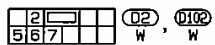
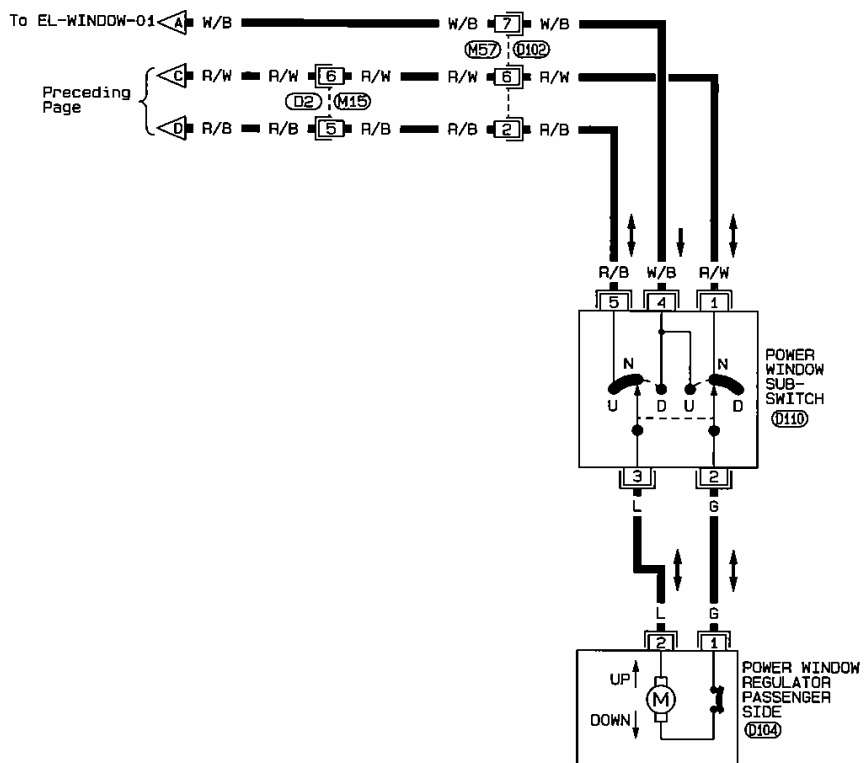

EL

HEL242

POWER WINDOW

Trouble Diagnoses

Symptom	Possible cause	Repair order
None of the power windows can be operated using any switch.	<ol style="list-style-type: none"> 1. 7.5A fuse, 25A fusible link and (M13) circuit breaker 2. Grounds (M1) and (M87) 3. Power window relay 4. Open/short in power window main switch circuit 	<ol style="list-style-type: none"> 1. Check 7.5A fuse (No. 26), located in fuse block), 25A fusible link (letter I), located in fuse and fusible link box) and (M13) circuit breaker. Turn ignition switch "ON" and verify battery positive voltage is present at terminal ① of power window main switch and terminal ④ of sub-switches. 2. Check grounds (M1) and (M87). 3. Check power window relay. 4. Check W/B wire between power window relay and power window main switch for open/short circuit.
Driver's side power window cannot be operated but passenger windows can be operated.	<ol style="list-style-type: none"> 1. Driver's side power window regulator circuit 2. Driver's side power window regulator 	<ol style="list-style-type: none"> 1. Check driver's side power window regulator circuit 2. Check driver's side power window regulator
Passenger power windows cannot be operated.	<ol style="list-style-type: none"> 1. Power window sub-switch 2. Passenger side power window regulators 3. Power window main switch 4. Power window circuit 	<ol style="list-style-type: none"> 1. Check power window sub-switch 2. Check passenger side power window regulator 3. Check power window main switch 4-1. Check harnesses between power window main switch and power window sub-switch for open/short circuit. 4-2. Check harnesses between power window sub-switch and passenger side power window regulator for open/short circuit.
Passenger power window cannot be operated using power window main switch but can be operated by power window sub-switch.	<ol style="list-style-type: none"> 1. Power window main switch 	<ol style="list-style-type: none"> 1. Check power window main switch.
Driver's side power window auto function cannot be operated using power window main switch.	<ol style="list-style-type: none"> 1. Power window main switch 	<ol style="list-style-type: none"> 1. Check power window main switch.

POWER DOOR MIRROR

Wiring Diagram — MIRROR —

RHD MODELS

EL-MIRROR-03

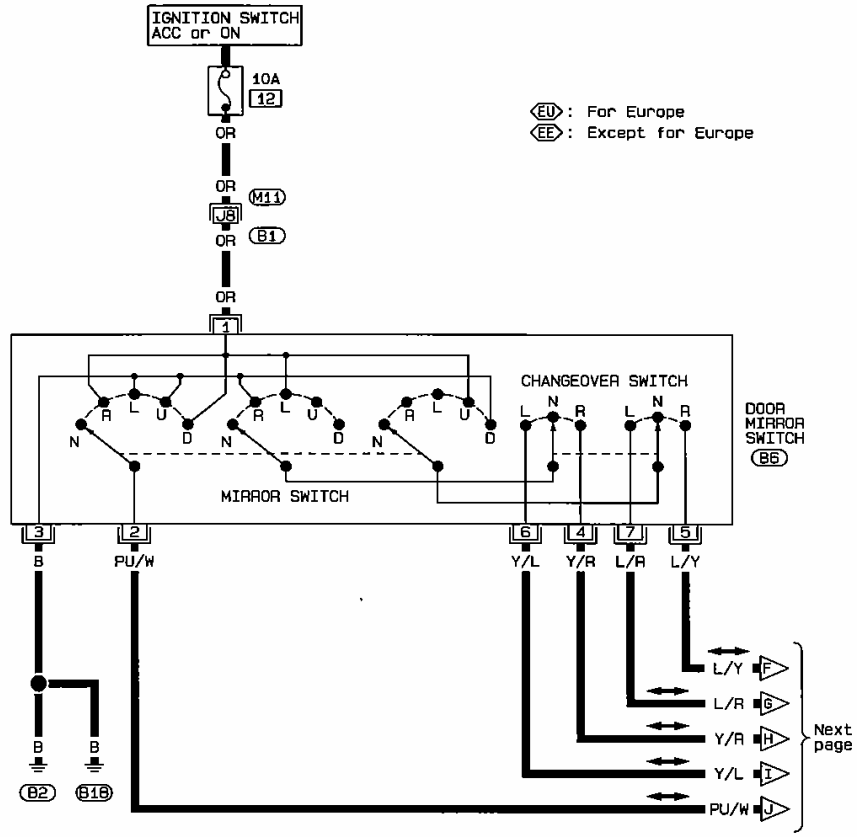

(EU): For Europe
(EE): Except for Europe

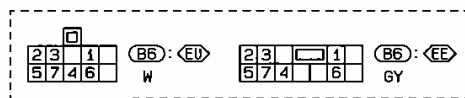

Refer to last page (Foldout page).

(M11), (B1)

EL

HEL386

POWER DOOR MIRROR

Wiring Diagram — MIRROR — (Cont'd)

EL-MIRROR-04

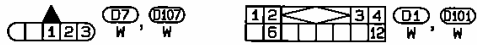
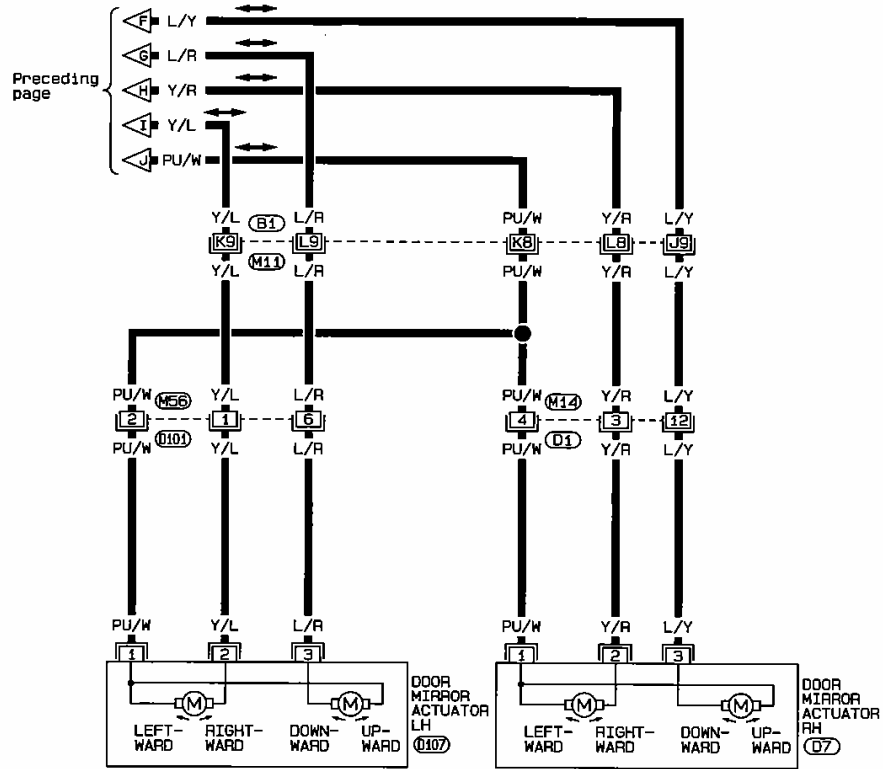

Refer to last page (Foldout page).

(M11), (B1)

SEL838T

MULTI-REMOTE CONTROL SYSTEM

Wiring Diagram — MULTI —

EL-MULTI-01

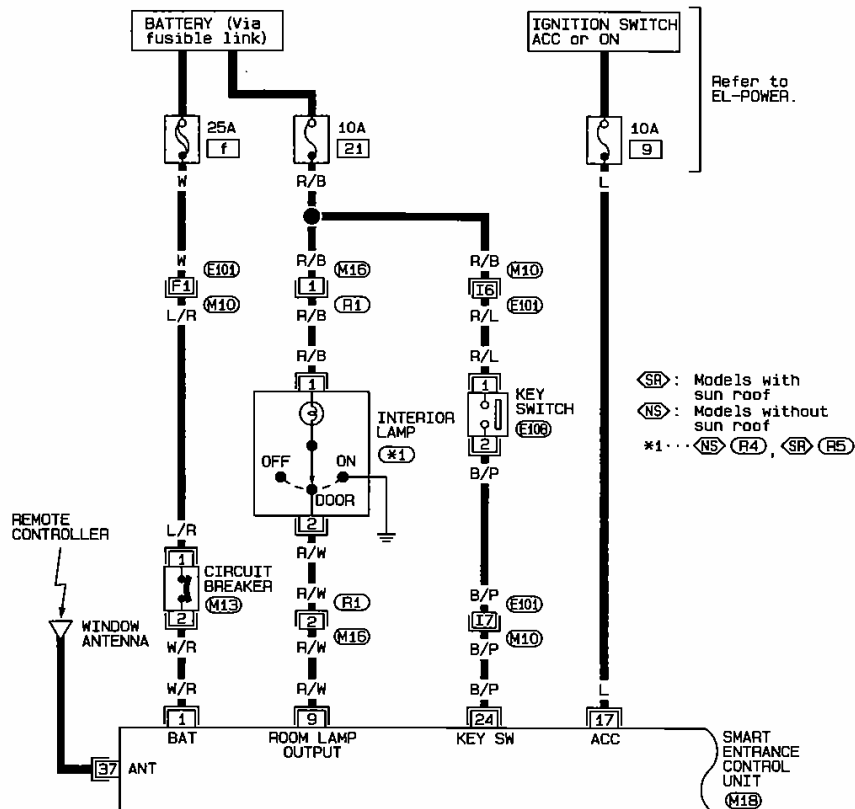

Refer to EL-POWER.

<SR>: Models with sun roof
 <NS>: Models without sun roof
 *1... <NS> <R4> <SR> <R5>

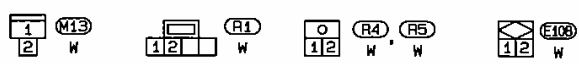

Refer to last page (foldout page).
 M10, E101
 M18

EL

MULTI-REMOTE CONTROL SYSTEM

Wiring Diagram — MULTI — (Cont'd)

EL-MULTI-02

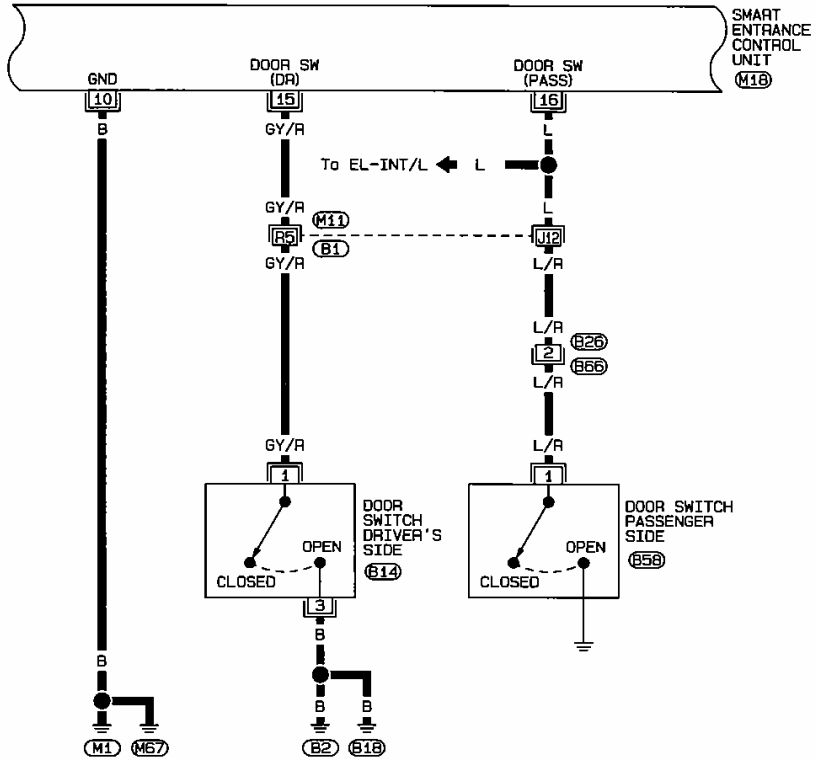

Refer to last page (Foldout page).

(M11), (B1)

(M18)

MULTI-REMOTE CONTROL SYSTEM

Wiring Diagram — MULTI — (Cont'd)

EL-MULTI-03

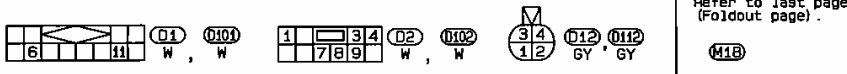
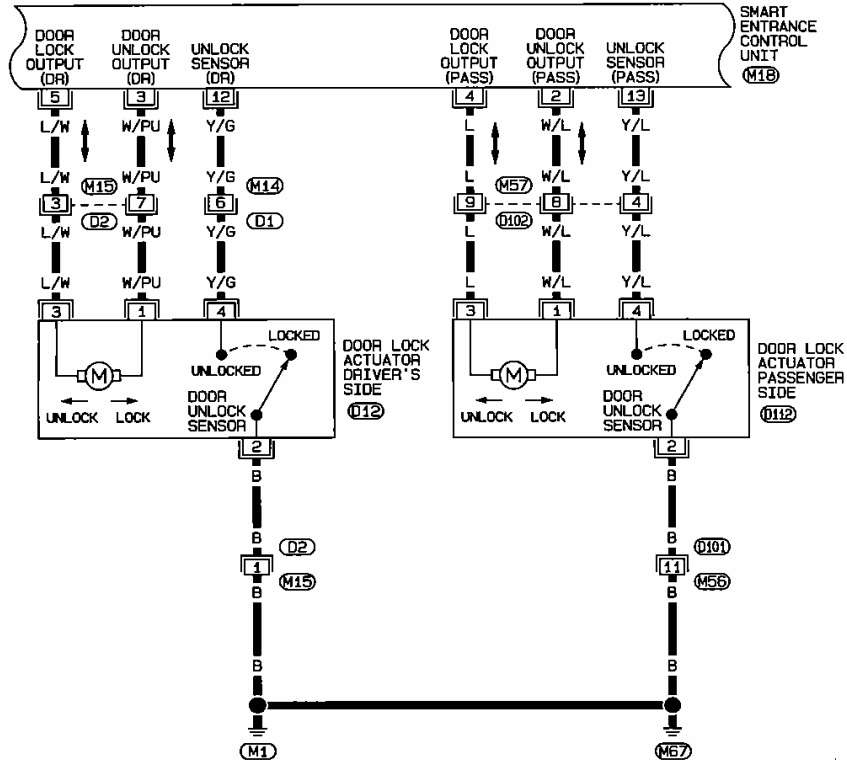

Refer to last page (Foldout page).

EL

MULTI-REMOTE CONTROL SYSTEM

Wiring Diagram — MULTI — (Cont'd)

EL-MULTI-04

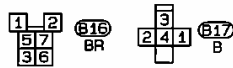
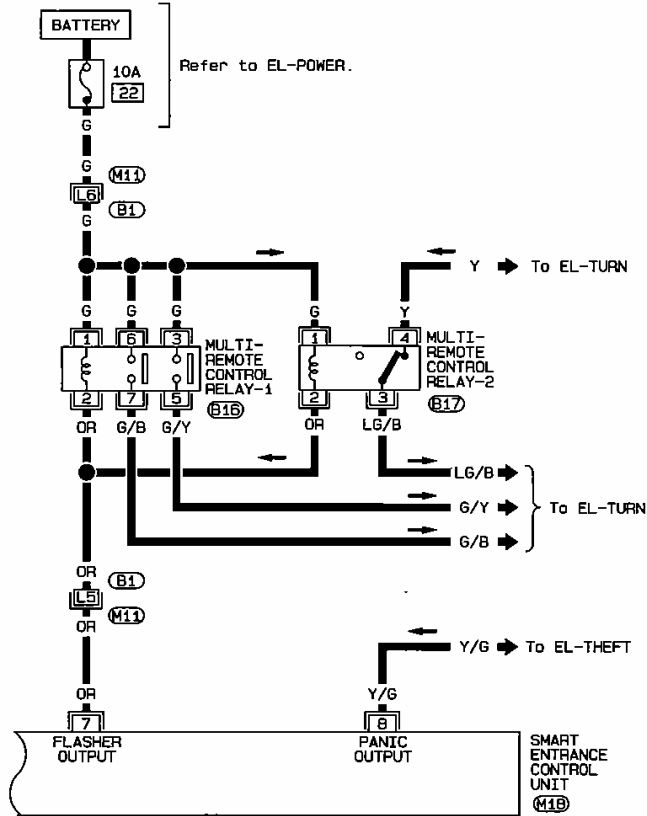

Refer to last page (Foldout page).

(M11), (B1)

(M18)

SEL773T

THEFT WARNING SYSTEM

Wiring Diagram — THEFT —

EL-THEFT-01

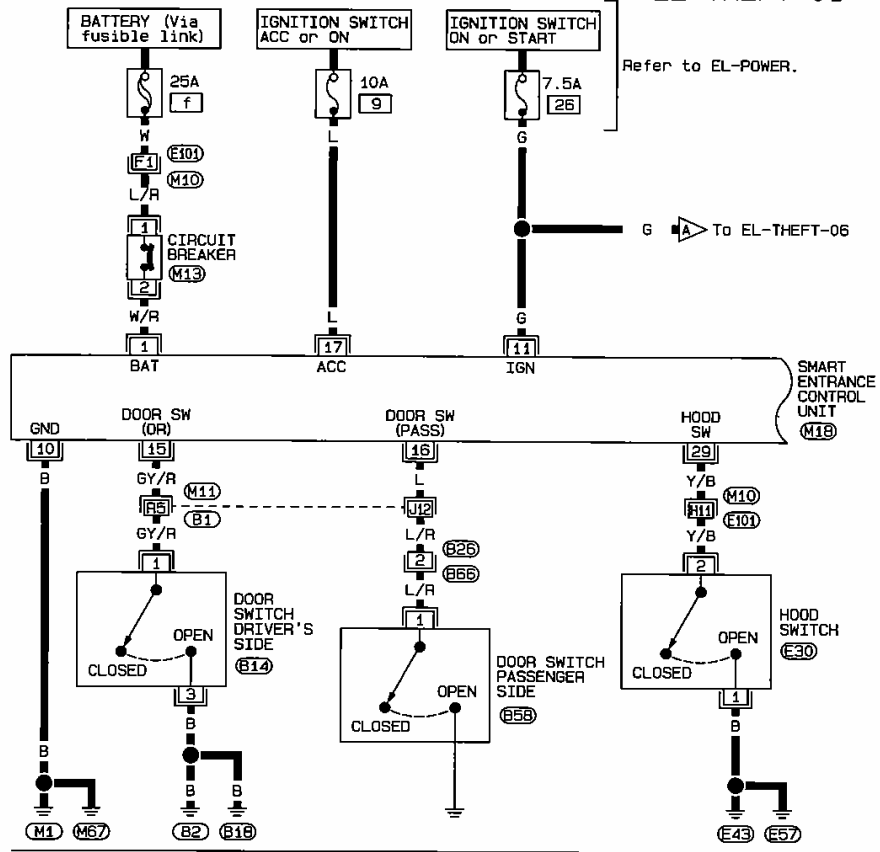

Refer to EL-POWER.

G → To EL-THEFT-06

SMART ENTRANCE CONTROL UNIT (M18)



Refer to last page (Foldout page).

- (M10), (E101)
- (M11), (B1)
- (M18)

EL

HEL244

THEFT WARNING SYSTEM

Wiring Diagram — THEFT — (Cont'd)

EL-THEFT-03

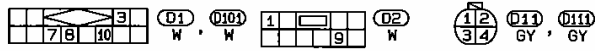
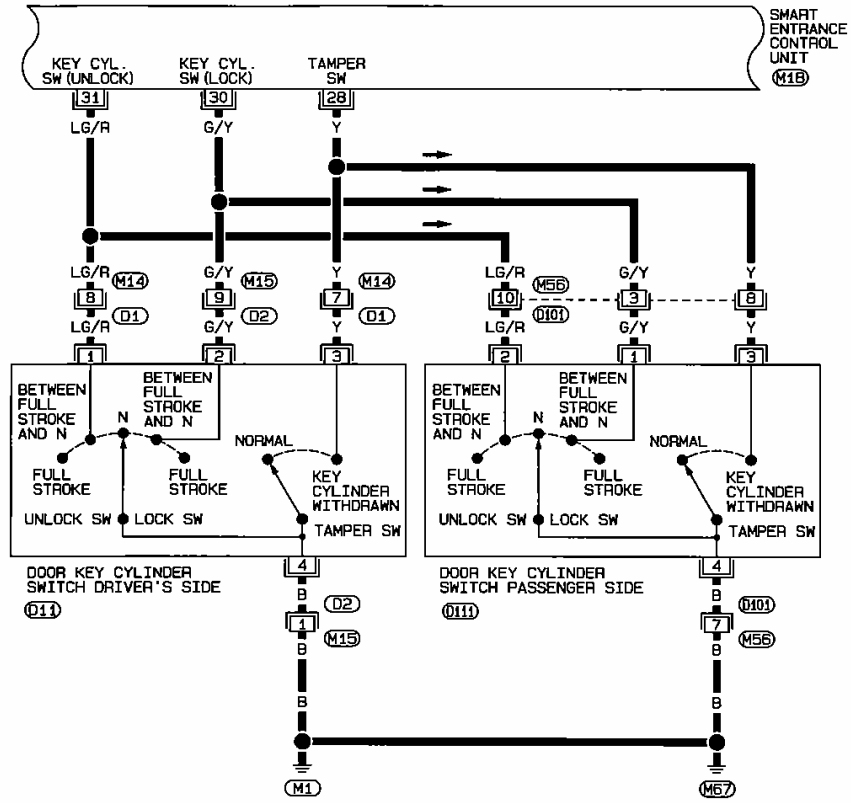

Refer to last page (Foldout page).

M1B

EL

SEL777T

THEFT WARNING SYSTEM

Wiring Diagram — THEFT — (Cont'd)

EL-THEFT-05

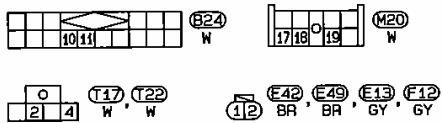
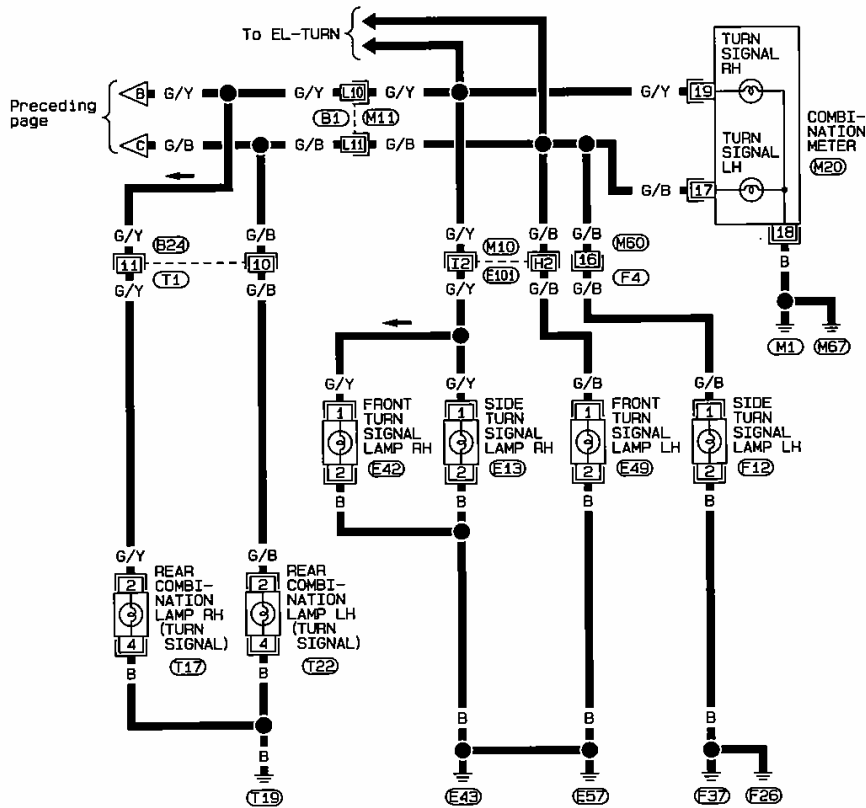

Refer to last page (Foldout page).

- (M10), (E101)
- (M11), (B1)
- (M50), (F4)

EL

SEL779T

THEFT WARNING SYSTEM

Wiring Diagram — THEFT — (Cont'd)

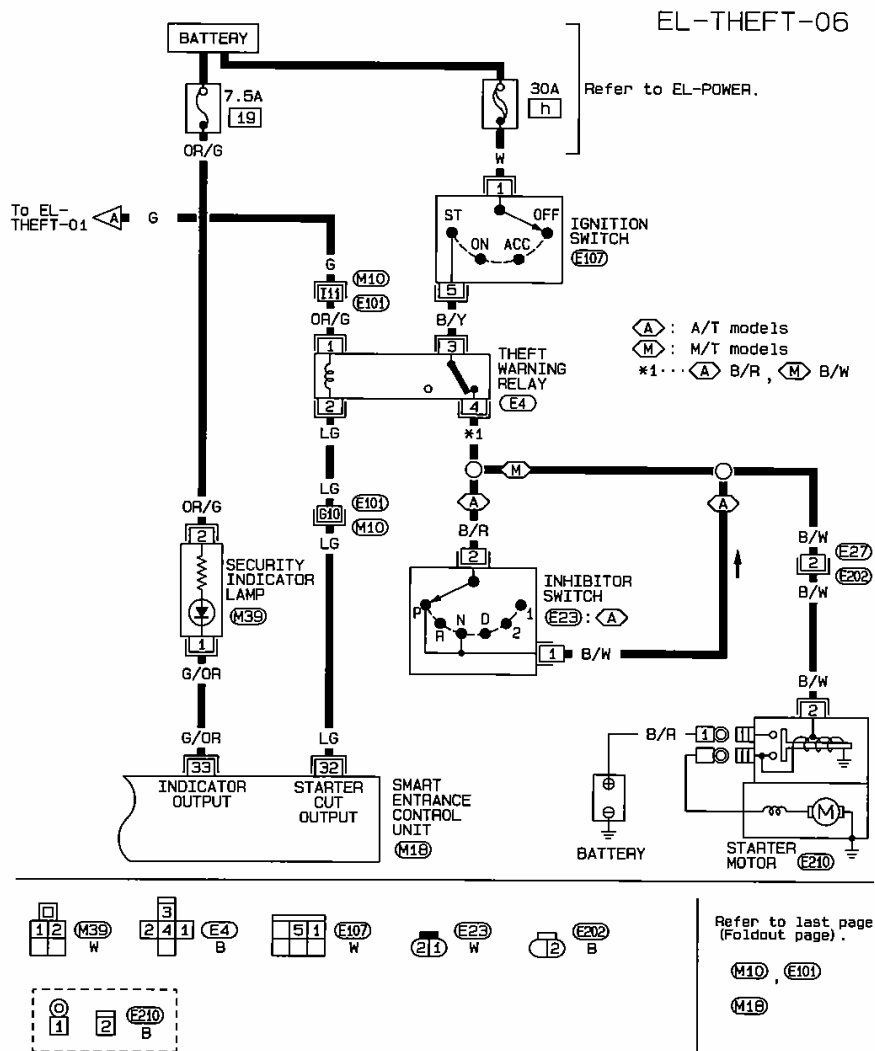

HEL245

NATS (Nissan Anti-Theft System)

System Description

NATS V2.0 for the S14 model has the following immobiliser functions:

- Since only NATS ignition keys, whose ID nos. have been registered into the ECM and IMMU of NATS, allow the engine to run, operation of a stolen vehicle without a NATS registered key is prevented by NATS.

That is to say, NATS V2.0 will immobilize the engine if someone tries to start it without the registered key of NATS V2.0.

- Both of the originally supplied ignition key IDs have been NATS registered.
If requested by the vehicle owner, a maximum of four key IDs can be registered into the NATS components.
- The NATS security indicator (NATS security ind.) blinks when the ignition switch is in "OFF" or "ACC" position. Therefore, NATS warns outsiders that the vehicle is equipped with the anti-theft system.
- When NATS detects trouble, the malfunction indicator lamp (MIL) blinks.
- NATS trouble diagnoses, system initialisation and additional registration of other NATS ignition key IDs must be carried out using CONSULT hardware and CONSULT NATS software.
When NATS initialisation has been completed, the ID of the inserted ignition key is automatically NATS registered. Then, if necessary, additional registration of other NATS ignition key IDs can be carried out.

Regarding the procedures of NATS initialisation and NATS ignition key ID registration, refer to CONSULT operation manual, NATS V2.0.

- When diagnosing NATS V2.0 using CONSULT, adapter and adapter harness for NATS V1.0 are not necessary, although a direct DDL cable connection between CONSULT and DDL connector is required.
- When servicing a malfunction of the NATS V2.0 (indicated by flashing of Malfunction Indicator Lamp) or registering another NATS ignition key ID no., it may be necessary to re-register original key identification. Therefore, be sure to receive all keys from vehicle owner.

System Composition

The immobiliser function of the NATS for the S14 model consists of the following:

- NATS ignition key
- NATS antenna amp. located in the ignition key cylinder
- NATS immobiliser control unit (NATS IMMU)
- Engine control module (ECM)
- NATS security indicator (NATS security ind.)
- Malfunction indicator lamp (MIL)

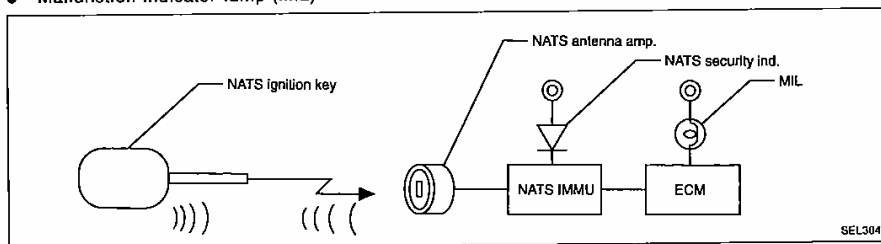

EL

NATS (Nissan Anti-Theft System)

Component Parts Location

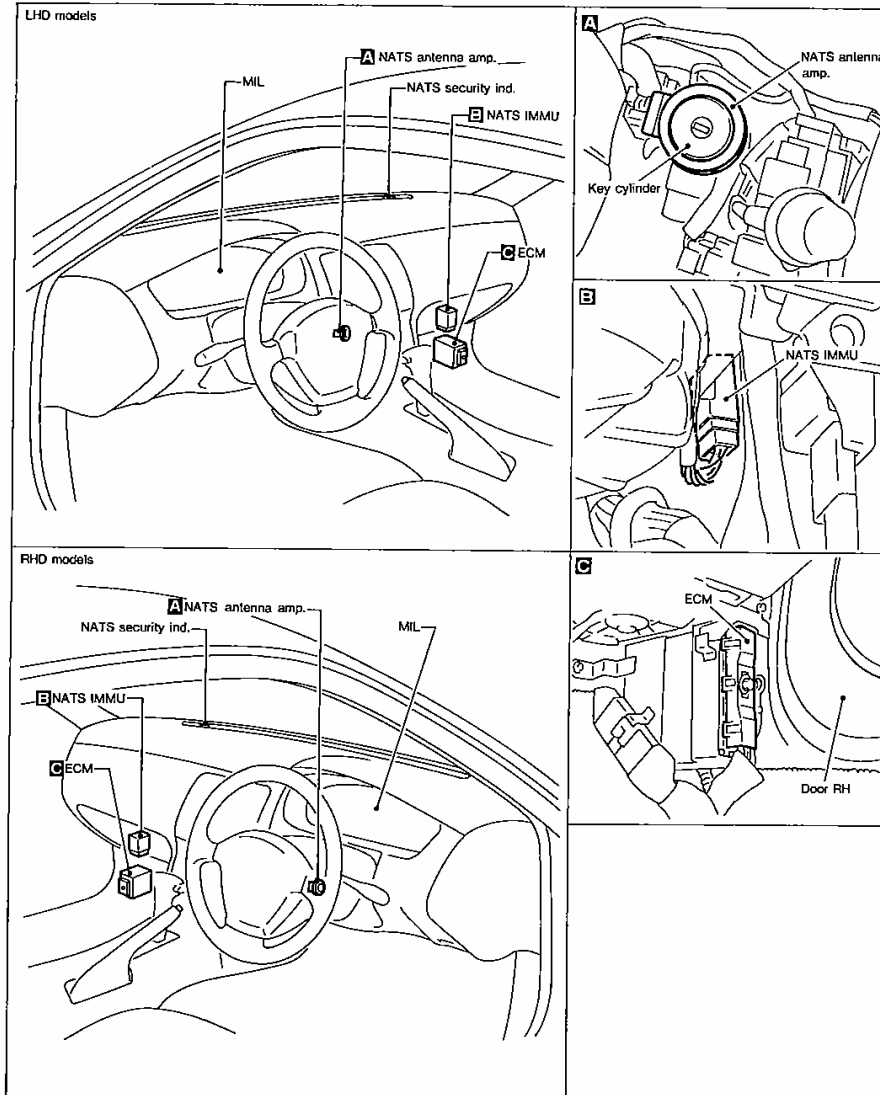

HEL250

NATS (Nissan Anti-Theft System)

Wiring Diagram — NATS —

LHD MODELS

EL-NATS-01

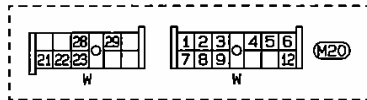
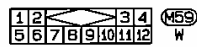
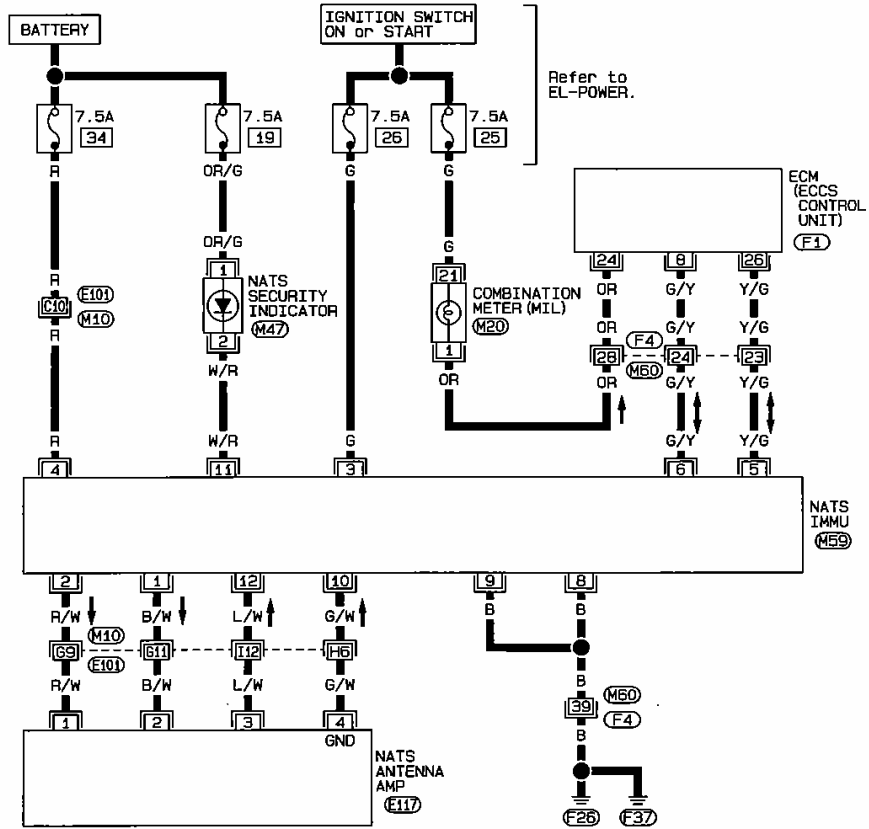

Refer to last page (Foldout page).

- (M10), (E101)
- (M60), (F4)
- (F1)

EL

NATS (Nissan Anti-Theft System)

Wiring Diagram — NATS — (Cont'd)

RHD MODELS

EL-NATS-02

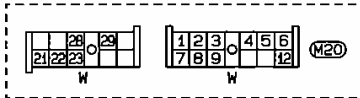
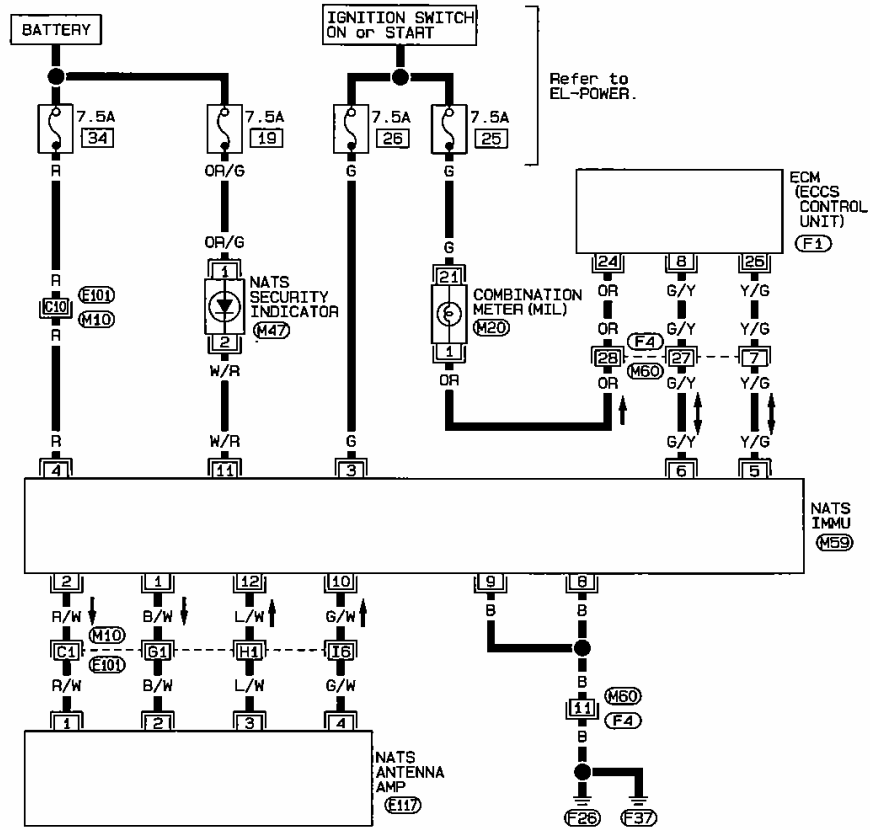

Refer to last page (Foldout page).

M10, E101

M60, F4

F1

NATS (Nissan Anti-Theft System)

Trouble Diagnoses

WORK FLOW

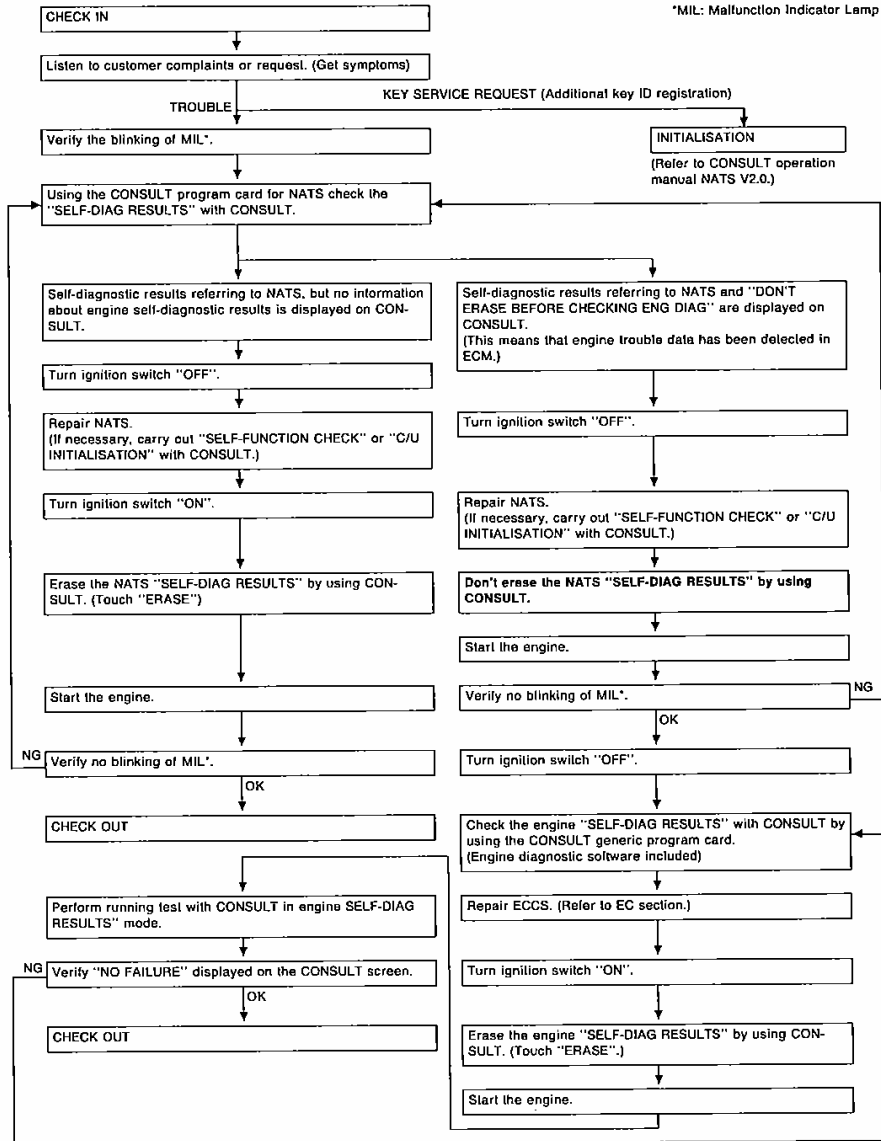

EL

NATS (Nissan Anti-Theft System)

Trouble Diagnoses (Cont'd)

CONSULT INSPECTION PROCEDURE

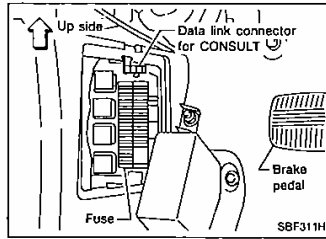

1. Turn off ignition switch.
2. Connect "CONSULT" to Data link connector for CONSULT. (Data link connector for CONSULT is located behind the fuse box cover.)

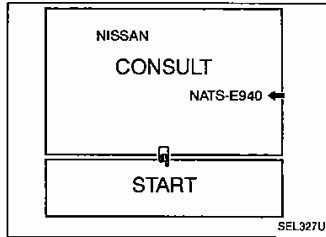

3. Insert NATS program card into CONSULT.

◀: Program card
NATS-E940

4. Turn on ignition switch.
5. Touch "START".

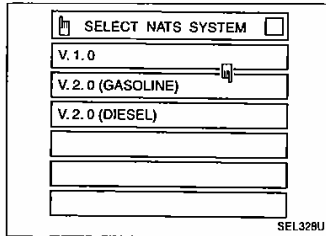

6. Touch "V.2.0 (GASOLINE)".

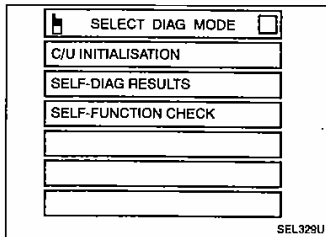

7. Perform each diagnostic test mode according to each service procedure.

For further information, see the CONSULT Operation Manual, NATS V2.0.

NATS (Nissan Anti-Theft System)

Trouble Diagnoses (Cont'd)

CONSULT DIAGNOSTIC TEST MODE FUNCTION

CONSULT DIAGNOSTIC TEST MODE	Description
C/U INITIALIZATION	When replacing any of following three components, C/U initialization is necessary. [NATS ignition key/IMMU/ECM]
SELF-FUNCTION CHECK	ECM checks its own NATS communication interface by itself.
SELF-DIAGNOSTIC RESULTS	Detected items (screen terms) are as shown in the chart below.

HOW TO READ SELF-DIAGNOSTIC RESULTS

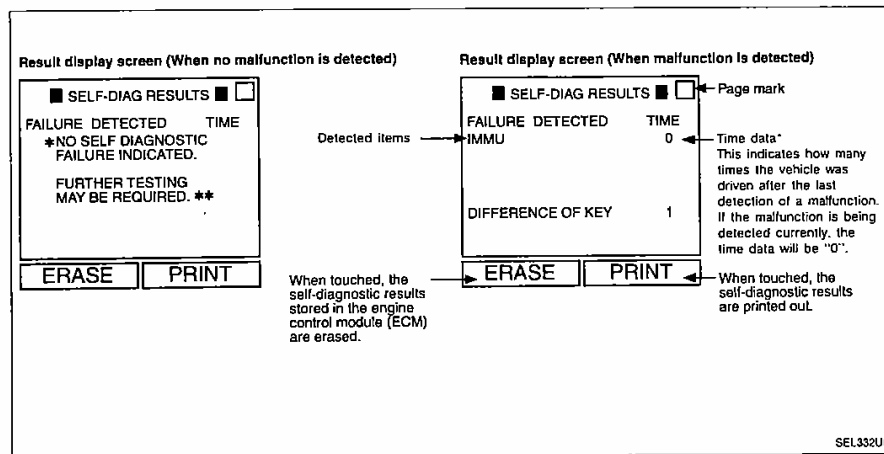

* If trip number is more than 1, MIL does not blink.

SELF-DIAGNOSTIC RESULTS ITEM CHART

Detected items (Screen terms)	Description	Reference page
IMMU	ECM received the signal from IMMU that IMMU is malfunctioning.	EL-72
ECM	ECM is malfunctioning.	EL-72
CHAIN OF ECM-IMMU	Communication impossible between ECM and IMMU.	EL-73
DIFFERENCE OF KEY	IMMU can receive the key ID signal but the result of ID verification between key ID and IMMU is NG.	EL-75
CHAIN OF IMMU-KEY	IMMU cannot receive the key ID signal.	EL-76
ID DISCORD, IMM-ECM	The result of ID verification between IMMU and ECM is NG. System initialisation is required.	EL-78
MINGLE NOISE	Noise (interference) mingled into NATS communication lines during communicating.	EL-79
DON'T ERASE BEFORE CHECKING ENG DIAG	Engine trouble data and NATS trouble data have been detected in ECM.	EL-67

EL

NATS (Nissan Anti-Theft System)

Trouble Diagnoses (Cont'd)

SYMPTOM MATRIX CHART 1 (Self-diagnosis related item)

X: Possibility item, *MIL: Malfunction Indicator Lamp

SYSTEM (Malfunctioning part or mode)	REFERENCE PART NO. OF ILLUSTRATION ON NEXT PAGE	SYMPTOM		Displayed "SELF-DIAG RESULTS" on CONSULT screen.	DIAGNOSTIC PROCEDURE (Reference page)
		● Blinking of MIL*. ● Engine will start.	● Blinking of MIL*. ● Hard to start engine.		
IMMU	A	X		IMMU	PROCEDURE 1 (EL-72)
ECM	B	X		ECM	PROCEDURE 2 (EL-72)
Open circuit in battery voltage line of IMMU circuit	C1		X	CHAIN OF ECM- IMMU	PROCEDURE 3 (EL-73)
Open circuit in ignition line of IMMU circuit	C2		X		
Open circuit in ground line of IMMU circuit	C3		X		
Open circuit in communication line between IMMU and ECM	C4		X		
Short circuit between IMMU and ECM communication line and battery voltage line	C4		X		
Short circuit between IMMU and ECM communication line and ground line	C4		X		
Open circuit in power source line of ANT/AMP circuit	E3		X		
ECM	B		X		
IMMU	A		X		
Unregistered key	D		X		
IMMU	A		X	CHAIN OF IMMU-KEY	PROCEDURE 5 (EL-76)
Communication line between ANT/AMP and IMMU: Open circuit or short circuit of battery voltage line or short circuit of ground line	E1		X		
	E2		X		
Open circuit in power source line of ANT/AMP circuit	E3		X		
Open circuit in ground line of ANT/AMP circuit	E4		X		
Malfunction of key ID chip	E5		X		
IMMU	A		X		
Antenna amp.	E6		X		

NATS (Nissan Anti-Theft System)

Trouble Diagnoses (Cont'd)

X: Possibility item. *MIL: Malfunction Indicator Lamp

SYSTEM (Malfunctioning part or mode)	REFERENCE PART NO. OF ILLUSTRATION ON NEXT PAGE	SYMPTOM		Displayed "SELF-DIAG RESULTS" on CONSULT screen.	DIAGNOSTIC PROCEDURE (Reference page)
		● Blinking of MIL*. ● Engine will start.	● Blinking of MIL*. ● Hard to start engine.		
System Initialisation has not yet been completed.	F		X	ID DISCORD, IMM-ECM	PROCEDURE 6 (EL-78)
ECM	F		X		
Noise interference in communication line			X	MINGLE NOISE	PROCEDURE 7 (EL-79)
Engine trouble data and NATS trouble data have been detected in ECM		X	X	DON'T ERASE BEFORE CHECKING ENG DIAG	WORK FLOW (EL-67)

SYMPTOM MATRIX CHART 2 (Non self-diagnosis related item)

X: Possibility item

SYSTEM (Malfunctioning part or mode)	SYMPTOM	DIAGNOSTIC PROCEDURE (Reference page)
	NATS security ind. does not light up.	
NATS security ind.		
Open circuit between Fuse and NATS IMMU	X	PROCEDURE 8 (EL-79)
Continuation of initialisation mode		
NATS IMMU		

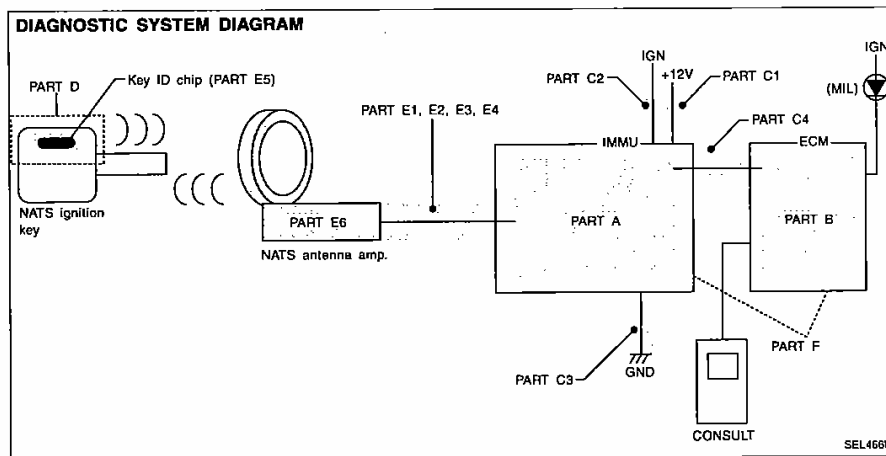

EL

NATS (Nissan Anti-Theft System)

Trouble Diagnoses (Cont'd) DIAGNOSTIC PROCEDURE 1

Self-diagnostic results:
"IMMU" displayed on CONSULT screen

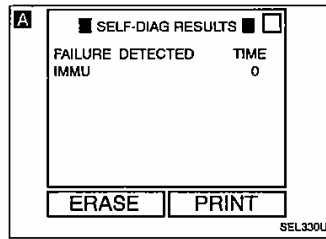

A

 Confirm SELF-DIAGNOSTIC RESULTS "IMMU" displayed on CONSULT screen.
Ref. part No.* A.

Yes

Replace IMMU.

 Perform initialisation with CONSULT.
For the operation of initialisation, refer to "CONSULT operation manual NATS V2.0".

* Ref. part No.: reference part No. of Diagnostic System Diagram on EL-71.

DIAGNOSTIC PROCEDURE 2

Self-diagnostic results:
"ECM" displayed on CONSULT screen

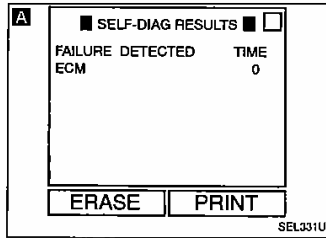

A

 Confirm SELF-DIAGNOSTIC RESULTS "ECM" displayed on CONSULT screen.
Ref. part No. B.

Replace ECM.

 Perform initialisation with CONSULT.
For the operation of initialisation, refer to "CONSULT operation manual NATS V2.0".

NATS (Nissan Anti-Theft System)

Trouble Diagnoses (Cont'd) DIAGNOSTIC PROCEDURE 3

Self-diagnostic results:
"CHAIN OF ECM-IMMU" displayed on CONSULT screen

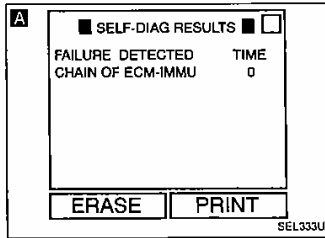

A Confirm SELF-DIAGNOSTIC RESULTS "CHAIN OF ECM-IMMU" displayed on CONSULT screen.

OK

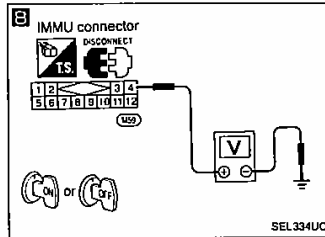

B Check voltage between terminal ④ of IMMU and ground with CONSULT or tester.
Voltage: Battery voltage

NG → Check the following:
 ● 7.5A fuse
 ● Harness continuity between fuse and IMMU connector (M59)
 If NG, repair harness or connector.
 Ref. part No. C1

OK

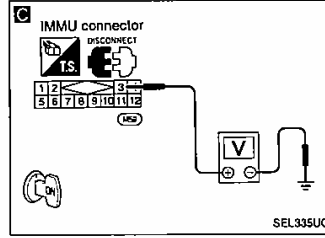

C Check voltage between terminal ③ of IMMU and ground with CONSULT or tester.
Voltage: Battery voltage

NG → Check the following:
 ● 7.5A fuse
 ● Harness continuity between fuse and IMMU connector (M59), or between ignition switch and fuse.
 If NG, repair harness or connectors.
 Ref. part No. C2

OK

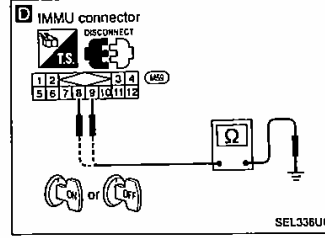

D Check harness continuity between IMMU terminal ⑥ or ⑨ and ground.
Continuity should exist.

NG → Repair harness or check the body ground screws. (F26) and (F37)
 Ref. part No. C3

OK

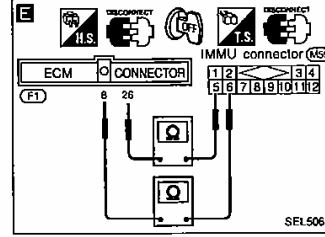

E Check harness continuity between the following ECM terminals and IMMU terminals.
 ECM ⑧ and IMMU ⑥
 ECM ②⑥ and IMMU ⑤
 Continuity should exist.

NG → Check the following.
 ● Harness connection between (F4) and (M50)
 ● Harness continuity between ECM and IMMU.
 If NG, repair harness or connectors.
 Ref. part No. C4

OK

A

EL

NATS (Nissan Anti-Theft System)

Trouble Diagnoses (Cont'd)

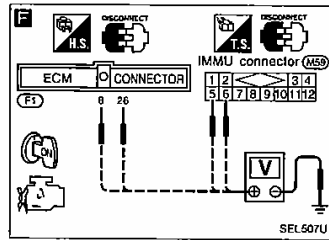

F CHECK COMMUNICATION LINE CIRCUIT.
 1) Disconnect ECM connector and IMMU connector.
 2) Check voltage between the following terminals and ground.
 ECM ⑧, ECM ⑨, IMMU ⑤ and IMMU ⑥
Voltage: 0V

NG → Communication line is short-circuited with battery voltage line or ignition switch ON line.
 Repair harness or connectors.
Ref. part No. C4

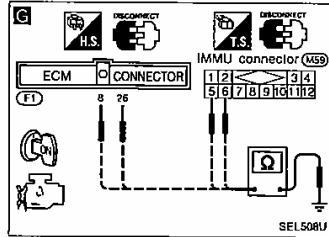

G Check continuity between the following terminals and ground.
 ECM ⑧, ECM ⑨, IMMU ⑤ and IMMU ⑥
Continuity should not exist.

NG → Communication line is short-circuited with ground line.
 Repair harness or connectors.
Ref. part No. C4

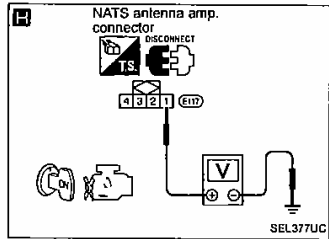

H CHECK NATS ANTENNA AMP. CIRCUIT.
 1) Disconnect NATS antenna amp. connector.
 2) Turn ignition switch "ON".
 3) Check voltage between antenna amp. terminal ① and ground.
Voltage: More than 4.7V

NG → NATS antenna amp. +5V line is short-circuited with battery voltage line or ground line.
 Repair harness or connectors.
Ref. part No. E3

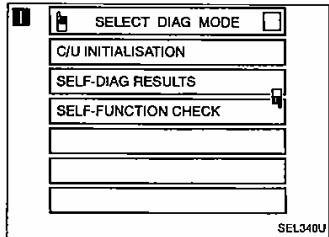

I SELF-FUNCTION CHECK
 1) Connect ECM connector and disconnect IMMU connector.
 2) Turn ignition switch "ON".
 3) Touch "SELF-FUNCTION CHECK" on CONSULT "SELECT DIAG MODE" screen.

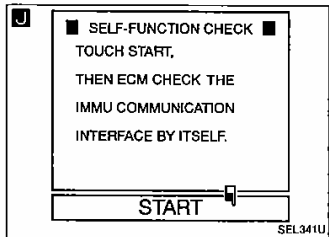

J Touch "START". ECM will then check its communication interface by itself.

NG → ECM is malfunctioning.
 Replace ECM.
Ref. part No. B

OK → IMMU is malfunctioning.
 Replace IMMU.
Ref. part No. A

OK → Perform initialisation with CONSULT.
 For the operation of initialisation, refer to "CONSULT operation manual NATS V2.0".

NATS (Nissan Anti-Theft System)

Trouble Diagnoses (Cont'd)

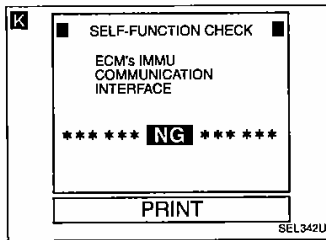

Ⓚ Perform initialisation with CONSULT.
For the operation of initialisation, refer to "CONSULT operation manual NATS V2.0".

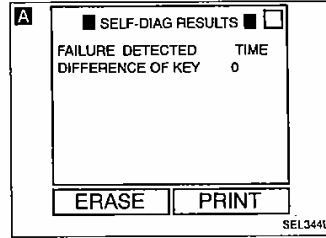
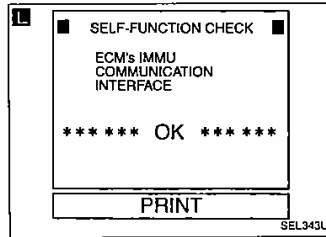

DIAGNOSTIC PROCEDURE 4

Self-diagnostic results:
"DIFFERENCE OF KEY" displayed on CONSULT screen

Ⓐ Confirm SELF-DIAGNOSTIC RESULTS "DIFFERENCE OF KEY" displayed on CONSULT screen.

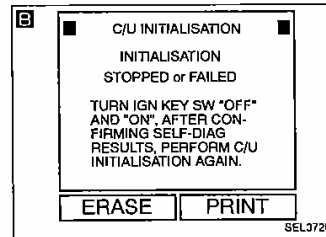

Ⓑ Perform initialisation with CONSULT.
Re-register all NATS ignition key IDs.
For the operation of initialisation, refer to "CONSULT operation manual NATS V2.0".

Initialisation incomplete or failed with CONSULT
Ⓑ IMMU is malfunctioning.
Replace IMMU.
Ref. part No. A

Initialisation completed
Start engine.

END
(Ignition key ID was unregistered.)
Ref. part No. D

Ⓚ Perform initialisation with CONSULT.
For the operation of initialisation, refer to "CONSULT operation manual NATS V2.0".

EL

NATS (Nissan Anti-Theft System)

Trouble Diagnoses (Cont'd) DIAGNOSTIC PROCEDURE 5

**Self-diagnostic results:
"CHAIN OF IMMU-KEY" displayed on CONSULT screen**

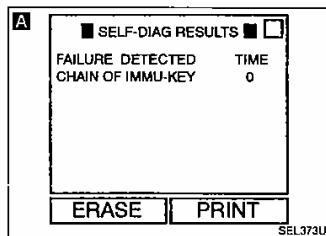

A Confirm SELF-DIAGNOSTIC RESULTS "CHAIN OF IMMU-KEY" displayed on CONSULT screen.

OK

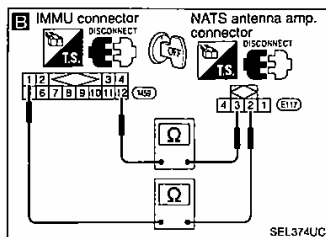

B CHECK ANTENNA AMP. CIRCUIT.
1) Disconnect IMMU connector and NATS antenna amp. connector.
2) Check continuity between the following IMMU terminals and NATS antenna amp. terminals.

IMMU terminal	NATS antenna amp. terminal	Ref. part No.
⑩	③	E1
①	②	E2

Continuity should exist.

NG Check harness and connectors.
If NG, repair harness or connectors.

OK

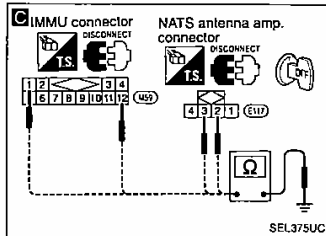

C Check continuity between the following terminals and ground.

IMMU terminal	NATS antenna amp. terminal	Ref. part No.
⑩	③	E1
①	②	E2

Continuity should not exist.

NG Communication line is short-circuited with ground line.
Repair harness or connectors.

OK

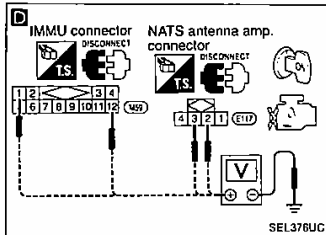

D Check voltage between the following terminals and ground.

IMMU terminal	NATS antenna amp. terminal	Ref. part No.
⑩	③	E1
①	②	E2

Voltage: 0V

NG Communication line is short-circuited with battery voltage line or ignition switch "ON" line.
Repair harness or connectors.

OK

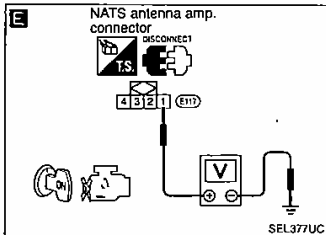

E CHECK ANTENNA AMP. POWER SOURCE CIRCUIT.
1) Connect IMMU connector.
2) Check voltage between NATS antenna amp. terminal ① and ground.
Voltage: More than 4.7V

NG Power source line is open circuit.
Repair harness or connector.
Ref. part No. E3

OK

A

NATS (Nissan Anti-Theft System)

Trouble Diagnoses (Cont'd)

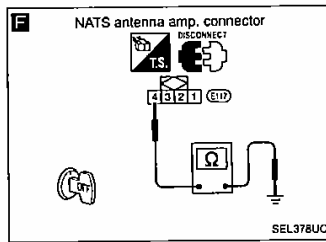

F
CHECK ANTENNA AMP. GROUND LINE CIRCUIT.
 1) Turn ignition switch "OFF".
 2) Check continuity between NATS antenna amp. terminal ④ and ground.
Continuity should exist.

NG
 NATS antenna amp. ground line is open circuit.
 Check harness continuity between IMM U terminal ⑩ and NATS antenna amp. terminal ④.
 If NG, repair harness or connectors.
Ref. part No. E4

OK
CHECK NATS IGNITION KEY ID CHIP.
 1) Connect NATS antenna amp. connector.
 2) Pull the ignition key out.
 3) Start engine with another registered NATS ignition key.

Start OK
 Ignition key ID chip was malfunctioning.
 Replace the ignition key.
Ref. part No. E5

Start NG
G
CHECK IMM U OUTPUT VOLTAGE.
 1) Turn the ignition switch "ON".
 2) Check voltage between IMM U terminal ② and ground.
Voltage: More than 4.7V

NG

 Perform initialisation with CONSULT.
 For the operation of initialisation, refer to "CONSULT operation manual NATS V2.0".

OK
 Replace IMM U.
Ref. part No. A

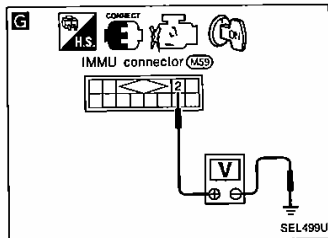

NG
H
CHECK IMM U GROUND CIRCUIT.
 1) Turn the ignition switch "OFF".
 2) Disconnect IMM U connector.
 3) Check continuity between IMM U terminal ⑩ and ground.
Continuity should exist.

NG
 Replace IMM U.
Ref. part No. A

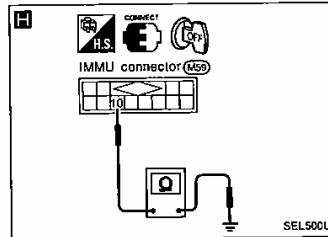

OK
I
CHECK IMM U FUNCTION 1.
 1) Connect IMM U connector and NATS antenna amp. connector.
 2) Check voltage between IMM U terminal ① and ground.

NG

 Perform initialisation with CONSULT.
 For the operation of initialisation, refer to "CONSULT operation manual NATS V2.0".

Voltage

Time (After turning ignition switch "ON":)	Voltage
For approx. 0.5 sec.	Approx. 2.3 - 5
After 1 sec.	0

NG
 Replace IMM U.
Ref. part No. A

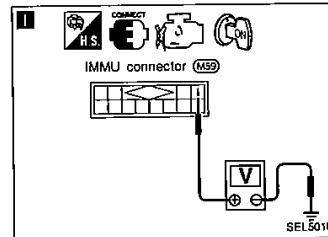

OK
 ⑧

EL

NATS (Nissan Anti-Theft System)

Trouble Diagnoses (Cont'd)

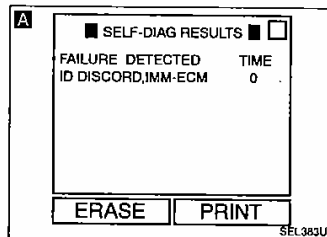
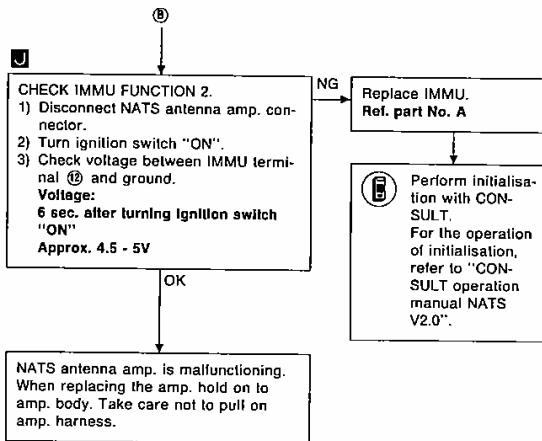
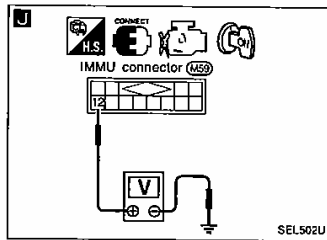

DIAGNOSTIC PROCEDURE 6

Self-diagnostic results:

"ID DISCORD, IMM-ECM" displayed on CONSULT screen

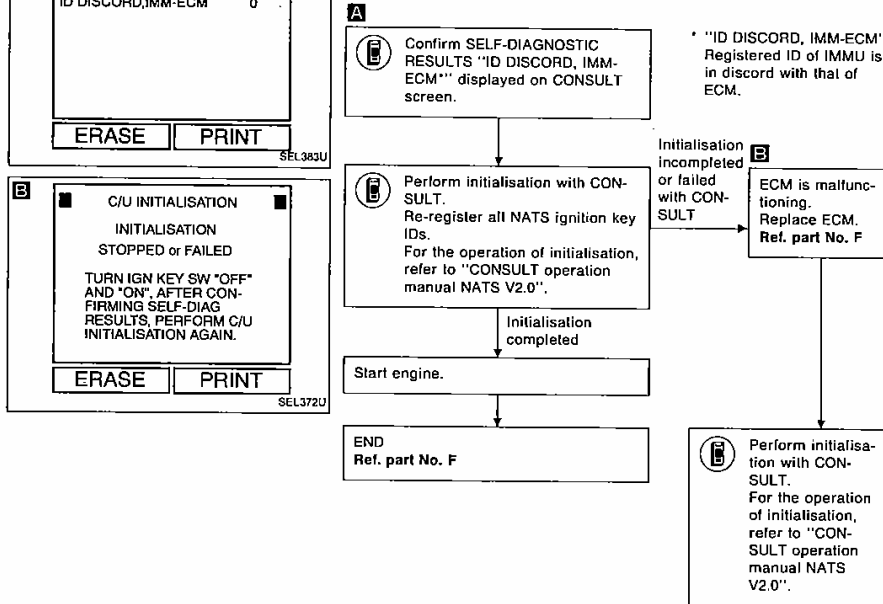

NATS (Nissan Anti-Theft System)

Trouble Diagnoses (Cont'd)

DIAGNOSTIC PROCEDURE 7

Self-diagnostic results:
"MINGLE NOISE" displayed on CONSULT screen

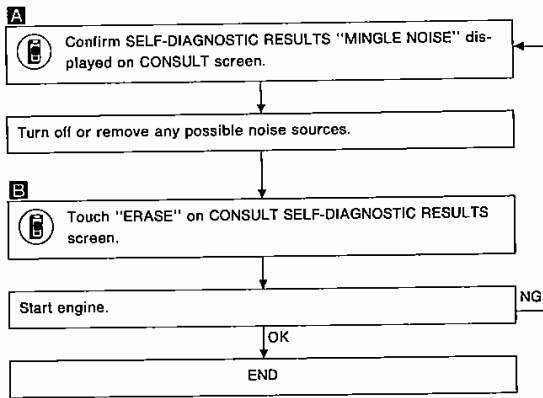
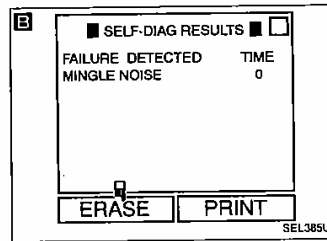
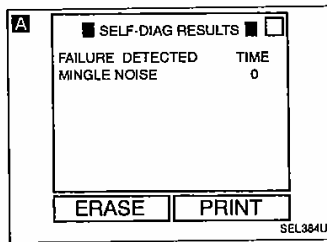

DIAGNOSTIC PROCEDURE 8

"NATS SECURITY IND. DOES NOT LIGHT UP"

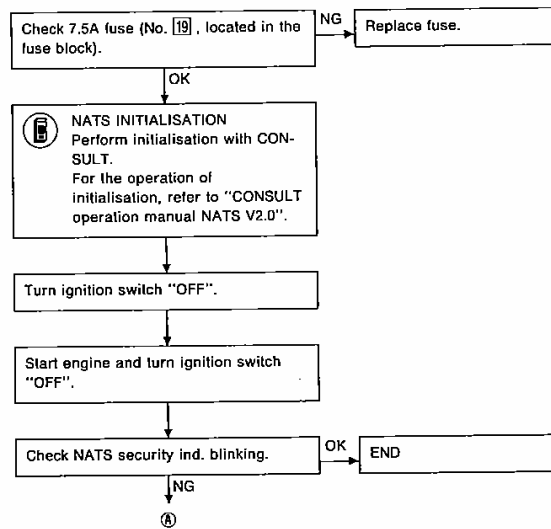

EL

NATS (Nissan Anti-Theft System)

Trouble Diagnoses (Cont'd)

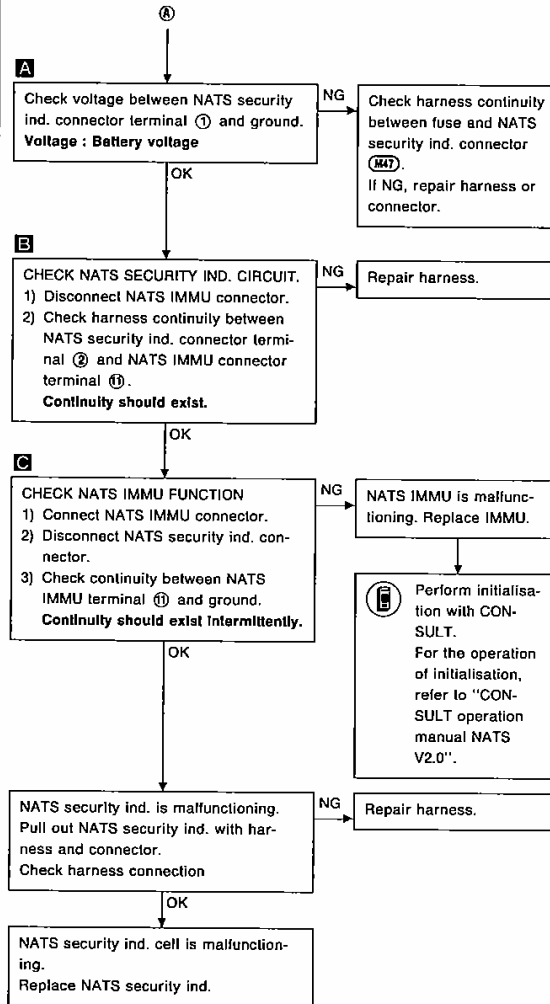
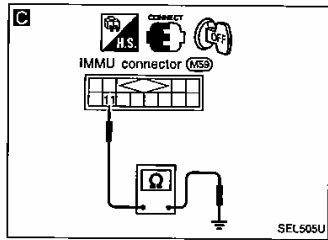
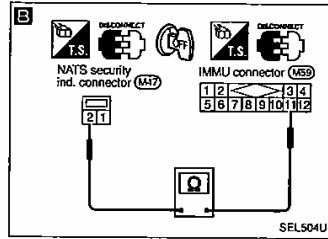
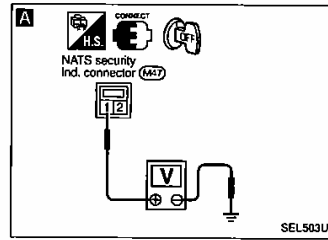

NATS (Nissan Anti-Theft System)

NOTE

EL

EL-81

LOCATION OF ELECTRICAL UNIT

Passenger Compartment

LHD MODELS

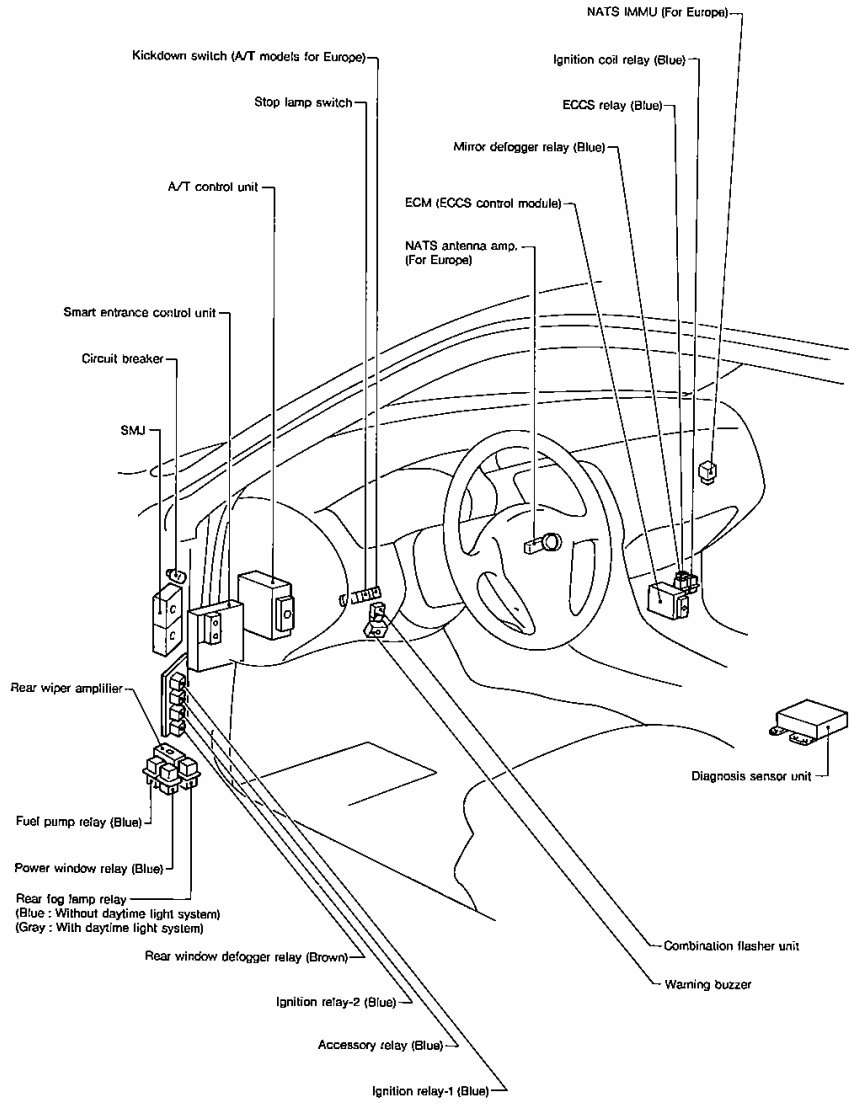

LOCATION OF ELECTRICAL UNIT

Passenger Compartment (Cont'd)

RHD MODELS

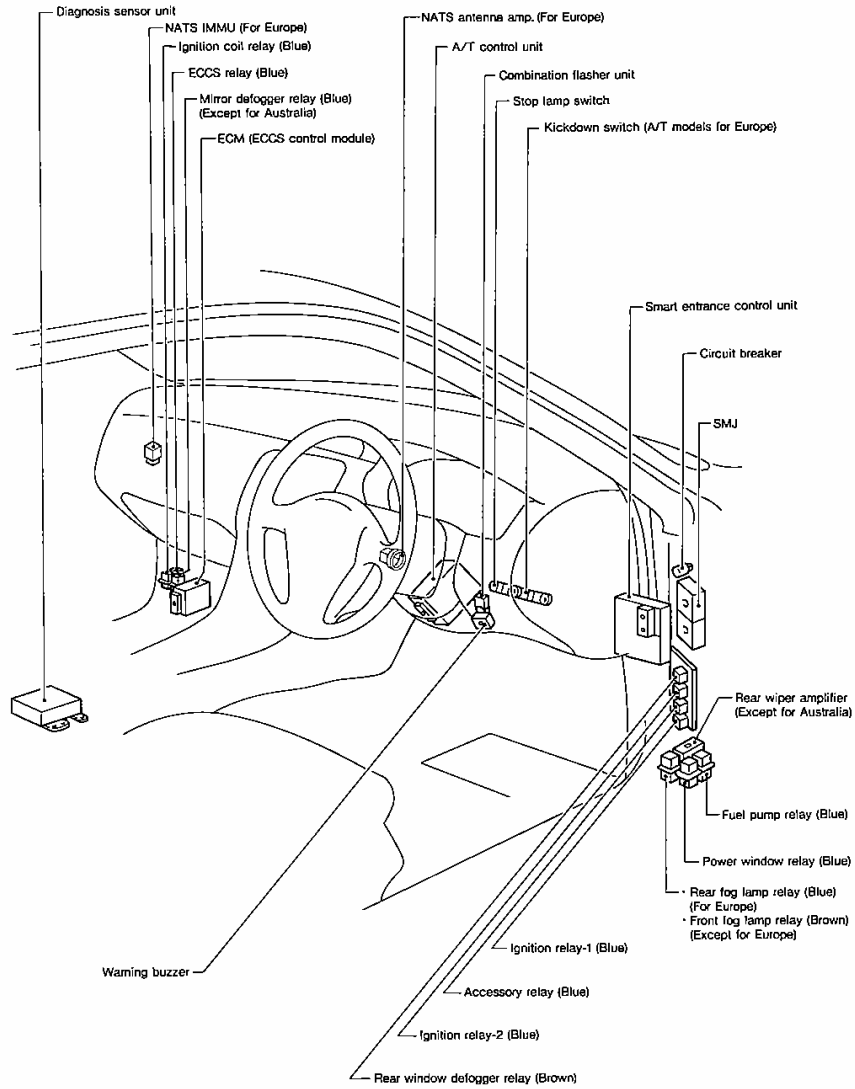

EL

HEL248

HARNES LAYOUT

Main Harness

LHD MODELS

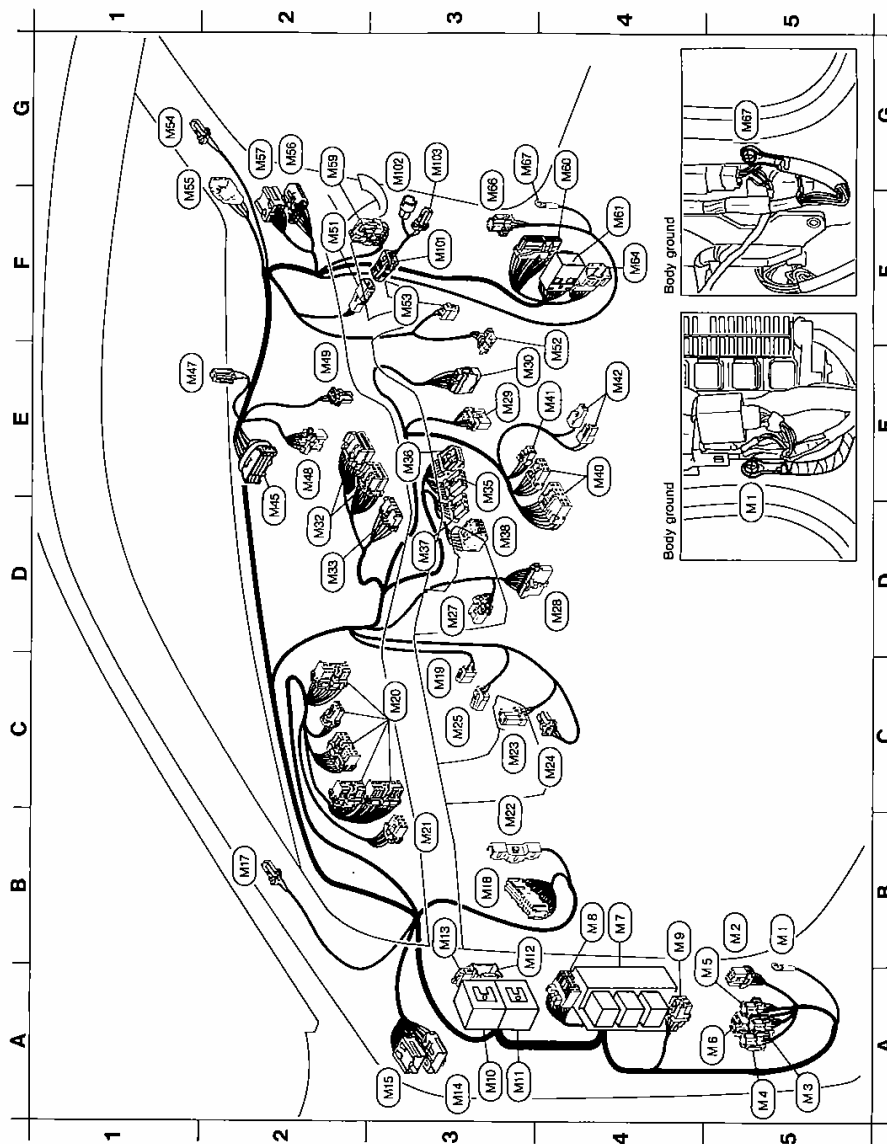

HARNES LAYOUT

Main Harness (Cont'd)

B5	(M1)	: Body ground	E2	(M46)	: Thermo control amplifier
B5	(M2)	: Rear wiper amplifier	F2	(M51)	: To (M10)
A5	(M3)	: Fuel pump relay	E4	(M52)	: Fan resistor
A5	(M4)	: Power window relay	F3	(M53)	: Blower motor
A5	(M5)	: Rear fog lamp relay (Models without daytime light system)	G1	(M54)	: Pillar speaker RH
A5	(M6)	: Rear fog lamp relay (Models with daytime light system)	F1	(M55)	: To (B1)
B4	(M7)	: Fuse block	G2	(M56)	: To (M10)
B4	(M8)	: Delete link connector for CONSULT	G2	(M57)	: To (M10)
B4	(M9)	: Rear window defogger relay	G2	(M58)	: NATS IMMU (For Europe)
A3	(M10)	: To (ED) (SMJ)	G4	(M60)	: To (F4)
A3	(M11)	: To (B1) (SMJ)	F4	(M61)	: To (E5) (A/T models)
B3	(M12)	: To (E10)	F4	(M64)	: To (E5)
B3	(M13)	: Circuit breaker	F3	(M65)	: Mirror defogger relay
A3	(M14)	: To (D1)	G3	(M67)	: Body ground
A3	(M15)	: To (D2)			
B2	(M17)	: Pillar speaker LH	F3	(M10)	: To (M51)
B3	(M18)	: Smart entrance control unit	G3	(M12)	: Glove box lamp
C3	(M19)	: Kickdown switch (A/T models)	G3	(M13)	: Glove box lamp switch
C3	(M20)	: Combination meter			
B3	(M21)	: Illumination control switch			
B3	(M22)	: A/T control unit (A/T models)			
C3	(M23)	: Combination flasher unit			
C4	(M24)	: Buzzer			
C3	(M25)	: Stop lamp switch			
D3	(M27)	: Air mix door motor			
D4	(M28)	: Mode door motor			
E3	(M29)	: BI-level door motor			
E3	(M30)	: To (Z5)			
D2	(M31)	: Push control unit			
D2	(M32)	: Fan switch			
E3	(M33)	: Hazard switch			
E3	(M34)	: Headlamp washer switch			
D3	(M37)	: Rear window defogger switch			
D3	(M38)	: Rear fog lamp switch			
E4	(M40)	: Radio			
E4	(M41)	: Not Used			
E4	(M42)	: Cigarette lighter			
D2	(M45)	: Joint connector			
E1	(M47)	: NATS security indicator (For Europe)			
E2	(M48)	: Intake door motor			



HARNES LAYOUT

Main Harness (Cont'd)

RHD MODELS

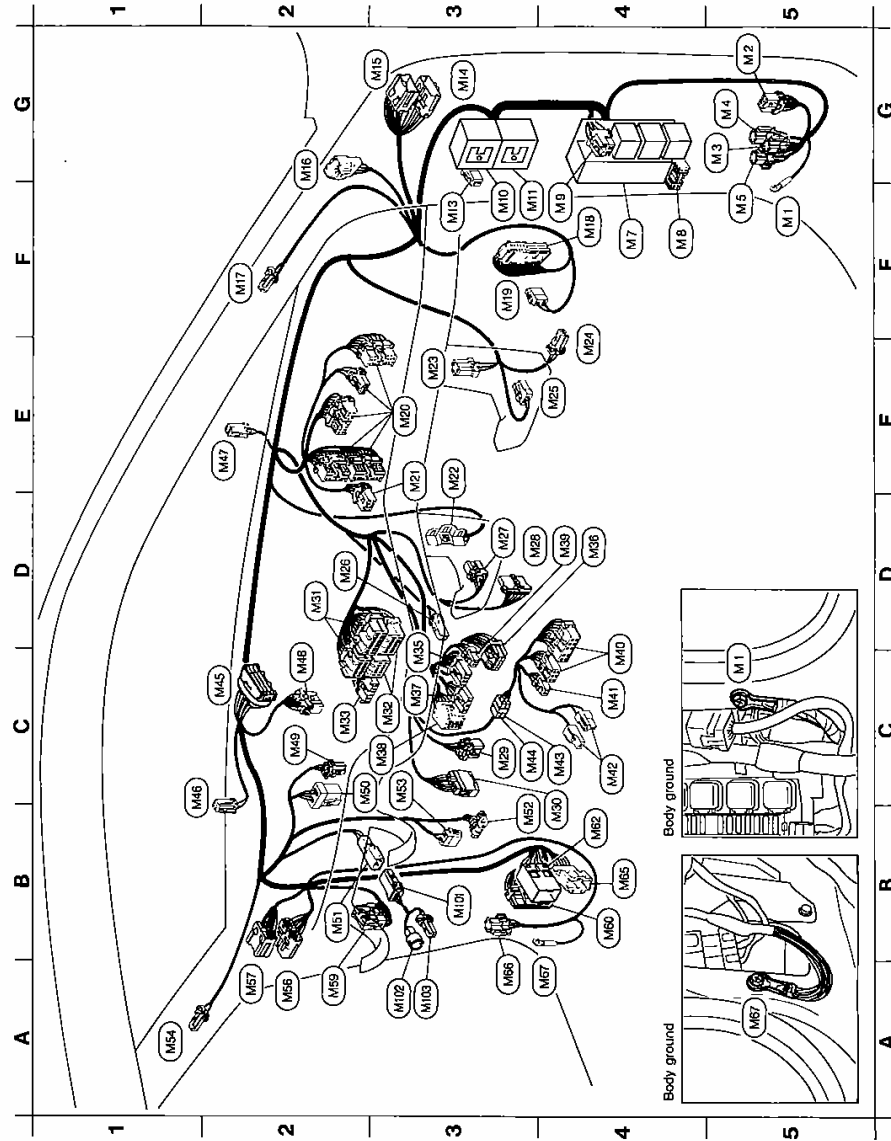

HARNES LAYOUT

Main Harness (Cont'd)

- F5 (M1) : Body ground
- G5 (M2) : Rear wiper amplifier (Except for Australia)
- G6 (M3) : Fuel pump relay
- G6 (M4) : Power window relay
- F6 (M5) : Rear fog lamp relay (For Europe)
- F4 (M7) : Fuse block
- F4 (M8) : Data link connector for CONSULT
- F4 (M9) : Rear window delogger relay
- F3 (M10) : To (E10) (SMJ)
- F3 (E11) : To (E1) (SMJ)
- G3 (M13) : Circuit breaker
- G3 (M14) : To (D1)
- G3 (M15) : To (D2)
- G2 (M16) : To (E1)
- F2 (M17) : Pillar speaker RH
- F4 (M18) : Smart entrance control unit
- F3 (M19) : Kickdown switch (A/T models)
- E3 (M20) : Combination meter
- E3 (M21) : Illumination control switch
- E3 (M22) : A/T control unit (A/T models)
- E4 (M23) : Combination flasher unit
- E4 (M24) : Buzzer
- E4 (M25) : Stop lamp switch
- D2 (M26) : In-vehicle sensor (Auto A/C)
- D3 (M27) : Air mix door motor
- D3 (M28) : Mode door motor
- C3 (M29) : Bi-level door motor
- B4 (M30) : To (E3)
- D2 (M31) : Auto A/C unit (Auto A/C)
- C3 (M32) : Push control unit (Except auto A/C)
- C2 (M33) : Fan switch (Except auto A/C)
- C3 (M34) : Hazard switch
- D4 (M35) : Headlamp washer switch (For Europe)
- C3 (M37) : Rear window delogger switch
- C3 (M38) : Rear fog lamp switch (For Europe)
- D4 (M39) : Security indicator (Except for Europe)
- C4 (M40) : Radio
- C4 (M41) : Not used
- C4 (M42) : Cigarette lighter

- C4 (M43) : Diode (Except for Europe)
- C3 (M44) : Diode (Except for Europe)
- B1 (M45) : Joint connector
- B1 (M46) : Sunload sensor (Auto A/C)
- E2 (M47) : NATS security indicator (For Europe)
- C2 (M48) : Intake door motor
- C2 (M49) : Thermo control amplifier
- C2 (M50) : Fan control amplifier (Auto A/C)
- B2 (M51) : To (E10) (Except for Australia)
- B3 (M52) : Fan resistor (Except auto A/C)
- A1 (M53) : Blower motor
- A1 (M54) : Pillar speaker LH
- A2 (M56) : To (D10)
- A2 (M57) : To (E12)
- A2 (M58) : NATS IMMJ (For Europe)
- B4 (M60) : To (E1)
- B4 (M62) : To (E7) (A/T models)
- B4 (M63) : To (E67) (Models with ABS)
- A3 (M65) : Mirror delogger relay (Except for Australia)
- A4 (M67) : Body ground

- B3 (M10) : To (M51)
- A3 (M109) : Glove box lamp
- A3 (M103) : Glove box lamp switch

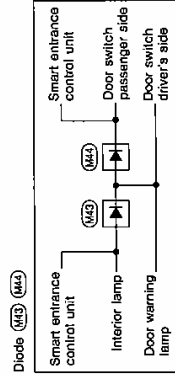

HARNES LAYOUT

Engine Room Harness

ENGINE COMPARTMENT (RHD models)

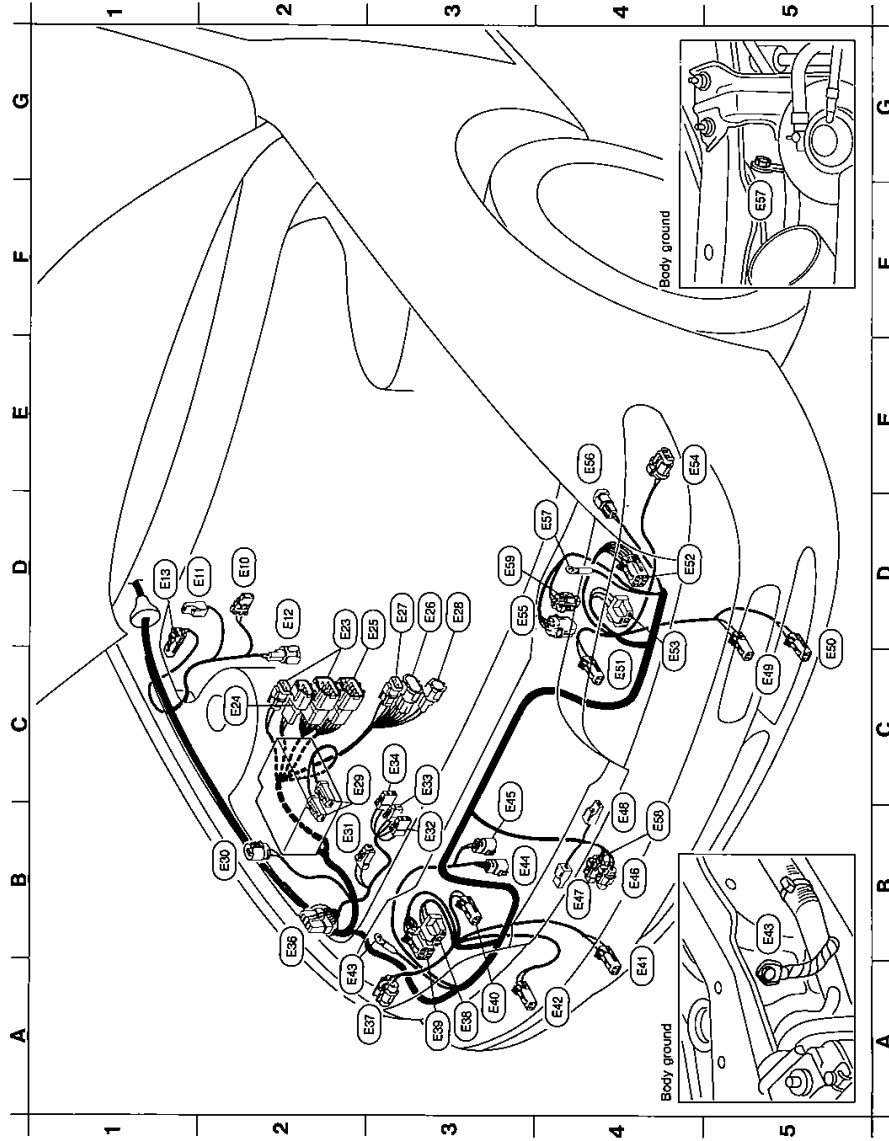

HEL207

HARNES LAYOUT

Engine Room Harness (Cont'd)

- C5 (E49) : Front turn signal lamp LH
- C5 (E50) : Front fog lamp LH
- C4 (E51) : Headlamp LH inner
- D4 (E52) : Headlamp aiming motor LH (For Europe)
- C4 (E53) : Headlamp LH outer
- E4 (E54) : Clearance lamp LH
- D3 (E55) : Triple-pressure switch (Except for Europe)
- E4 (E56) : To (E20)
- D4 (E57) : Body ground
- B4 (E58) : Ambient sensor (For outside temperature)
- D3 (E59) : Dual-pressure switch (For Europe)

(Fusible link and fuse box)

- (E1) : Cooling fan relay-2 (Except for Europe)
- (E2) : Fusible link and fuse block-1
- (E3) : Cooling fan relay-1
- (E4) : Theft warning relay (Except for Europe)
- (E5) : Air conditioner relay
- (E6) : Horn relay
- (E7) : Theft warning horn relay (Except for Europe)
- (E8) : Front fog lamp relay (For Europe)
- (E9) : Fusible link and fuse block-2
- (E10) : Fusible link and fuse block-3
- (E11) : Brake fluid level switch
- (E12) : Theft warning horn (Except for Europe)
- (E13) : Front wheel sensor RH (For ABS)
- (E14) : Side turn signal lamp RH
- (E15) : Inhibitor switch (A/T models)
- (E16) : Revolution sensor (A/T models)
- (E17) : To terminal code assembly (A/T models)
- (E18) : To (E20)
- (E19) : To (E20)
- (E20) : Battery
- (E21) : Hood switch (Except for Europe)
- (E22) : Washer fluid level switch
- (E23) : Headlamp washer motor (For Europe)
- (E24) : Front washer motor
- (E25) : Rear washer motor (Except for Australia)
- (E26) : Headlamp washer amplifier (For Europe)
- (E27) : Clearance lamp RH
- (E28) : Headlamp RH outer
- (E29) : Headlamp aiming motor RH (For Europe)
- (E30) : Headlamp RH inner
- (E31) : Front fog lamp RH
- (E32) : Front turn signal lamp RH
- (E33) : Body ground
- (E34) : Cooling fan motor (Except for Europe)
- (E35) : Cooling fan motor (For Europe)
- (E36) : Ambient sensor (For auto A/C)
- (E37) : Horn (High)
- (E38) : Horn (Low)

Fusible link and fuse box

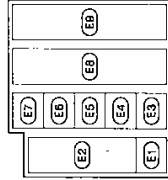

HARNES LAYOUT

Engine Room Harness (Cont'd)

PASSENGER COMPARTMENT (LHD models)

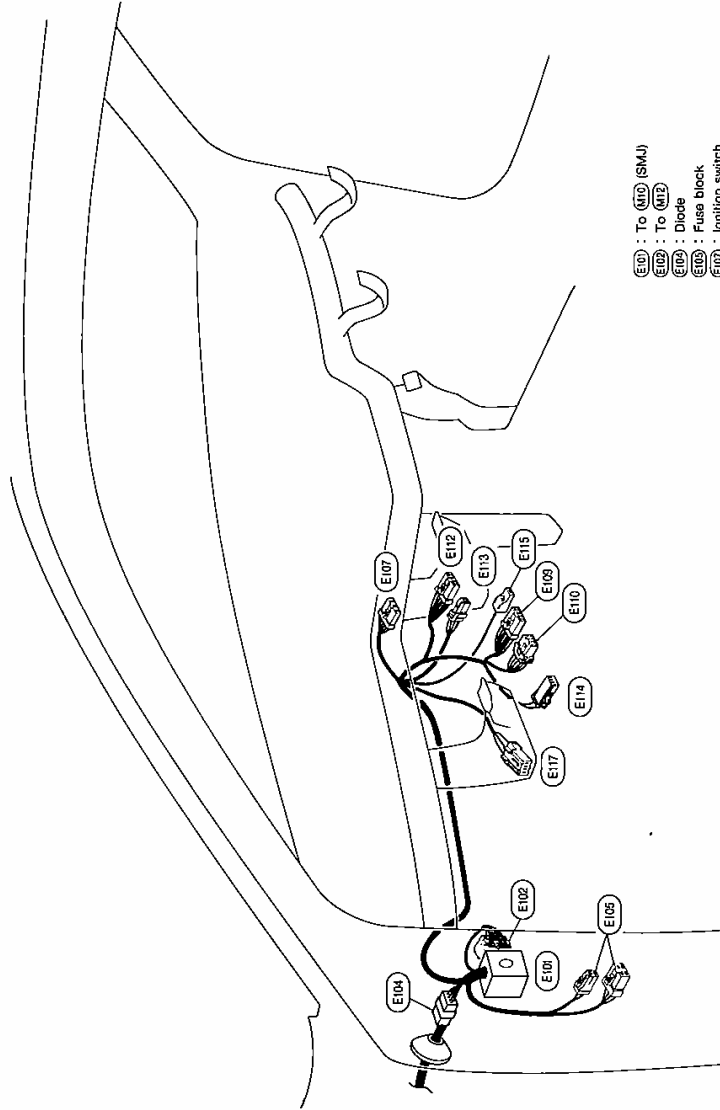

- E10 : To M10 (SMJ)
- E102 : To M12
- E104 : Diode
- E105 : Fuse block
- E106 : Ignition switch
- E107 : Lighting switch
- E108 : Turn signal switch
- E109 : Front wiper and washer switch
- E110 : Rear wiper and washer switch
- E111 : Rear fog lamp switch
- E112 : Horn switch
- E113 : NATS antenna amp. (For Europe)

Diode (E104)

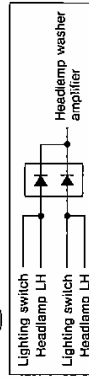

HARNESS LAYOUT

Engine Room Harness (Cont'd)

PASSENGER COMPARTMENT (RHD models)

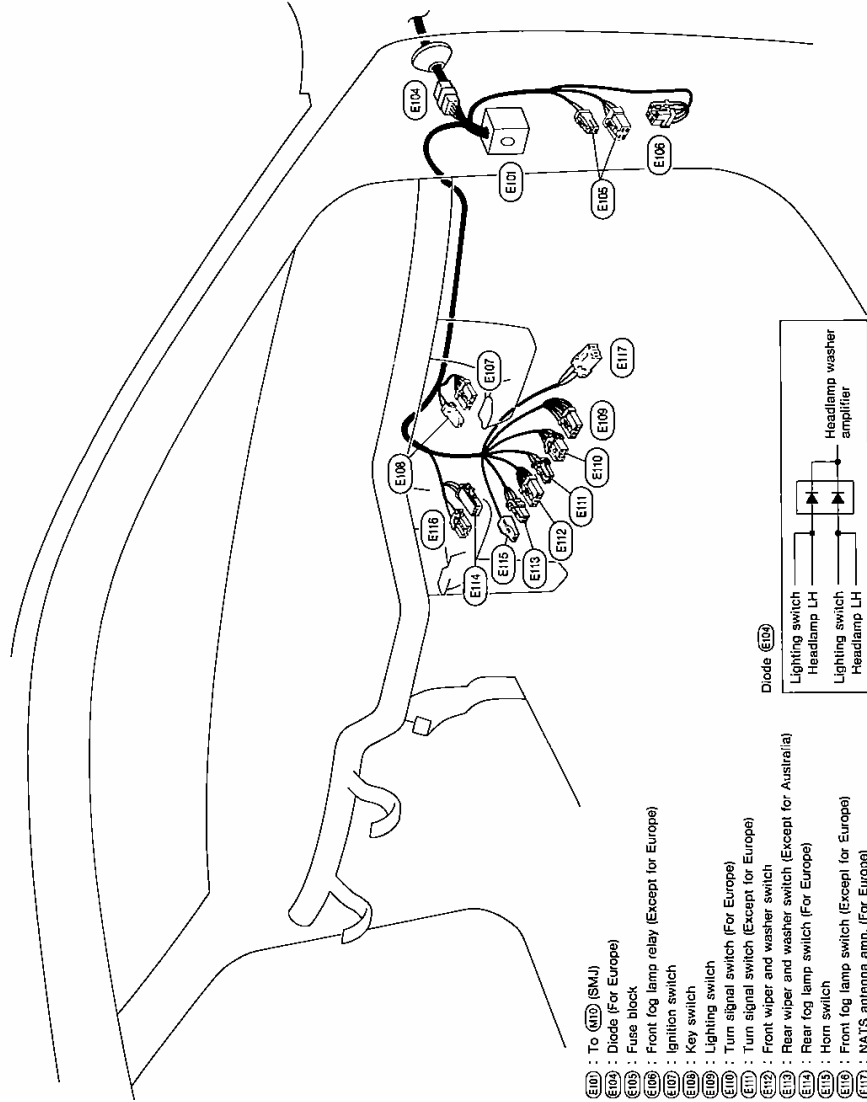

- E10 : To (M13) (SMJ)
- E104 : Diode (For Europe)
- E105 : Fuse block
- E106 : Front fog lamp relay (Except for Europe)
- E107 : Ignition switch
- E108 : Key switch
- E109 : Lighting switch
- E110 : Turn signal switch (For Europe)
- E111 : Turn signal switch (Except for Europe)
- E112 : Front wiper and washer switch
- E113 : Rear wiper and washer switch (Except for Australia)
- E114 : Rear fog lamp switch (For Europe)
- E115 : Horn switch
- E116 : Front fog lamp switch (Except for Europe)
- E117 : NATS antenna amp. (For Europe)

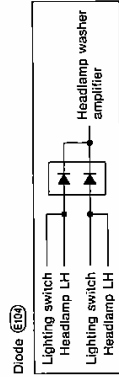

HARNESS LAYOUT

Engine Control Harness

LHD MODELS

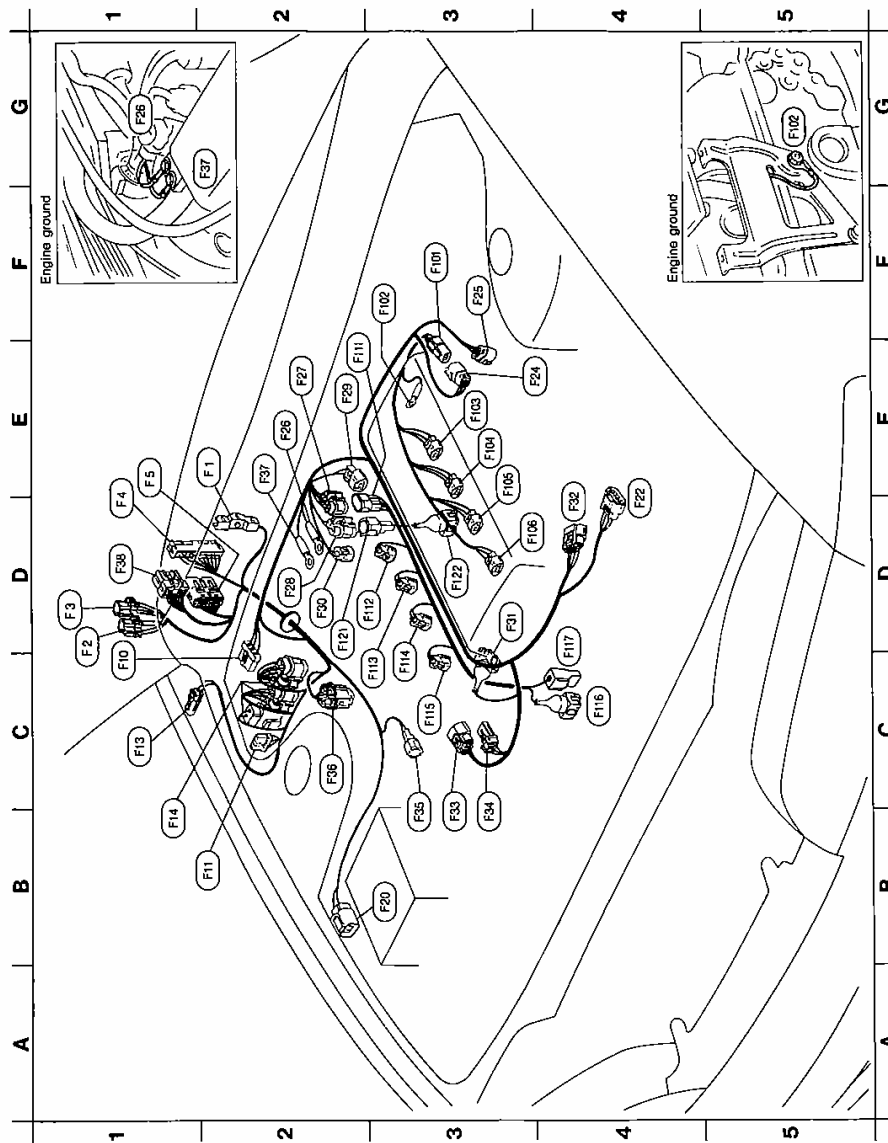

HARNES LAYOUT

Engine Control Harness (Cont'd)

E2	(F1)	: ECM (ECCS control module)	Sub-harness
D1	(F2)	: ECSS relay	F3 (F01) : To (F24)
D1	(F3)	: Ignition coil relay	F3 (F02) : Engine ground
D1	(F4)	: To (F03)	E3 (F03) : Ignition coil No.4
E1	(F5)	: To (E03)	E3 (F04) : Ignition coil No.3
C1	(F6)	: Front wiper motor	E3 (F05) : Ignition coil No.2
B2	(F1)	: Front wiper amplifier	D3 (F06) : Ignition coil No.1
C1	(F13)	: Side turn signal lamp RH	E2 (F17) : To (E27)
B1	(F14)	: ABS actuator	D3 (F12) : Injector No.4
B3	(F20)	: To (E05)	C3 (F13) : Injector No.3
D4	(F22)	: Mass air flow sensor	C3 (F14) : Injector No.2
E3	(F24)	: To (E10)	C3 (F15) : Injector No.1
F3	(F25)	: Heated oxygen sensor	C4 (F16) : Engine coolant temperature sensor
E2	(F26)	: Engine ground	C4 (F17) : Thermal transmitter
E2	(F27)	: To (E11)	D2 (F18) : To (F28)
D2	(F28)	: To (E12)	D3 (F22) : Knock sensor
E2	(F28)	: IACV/FICD solenoid valve	
D2	(F30)	: ICAV-AAC valve	
D3	(F31)	: VTC solenoid valve	
D4	(E26)	: Camshaft position sensor	
B3	(E33)	: Throttle position sensor (Brown)	
B3	(F34)	: Throttle position switch (Grey) (A/T models)	
B3	(F35)	: Front wheel sensor RH (For ABS)	
C2	(F36)	: Triple-pressure switch	
E2	(F37)	: Engine ground	
D1	(F38)	: To (E01) (A/T models)	

EL

HEL212

HARNES LAYOUT

Engine Control Harness (Cont'd)

RHD MODELS

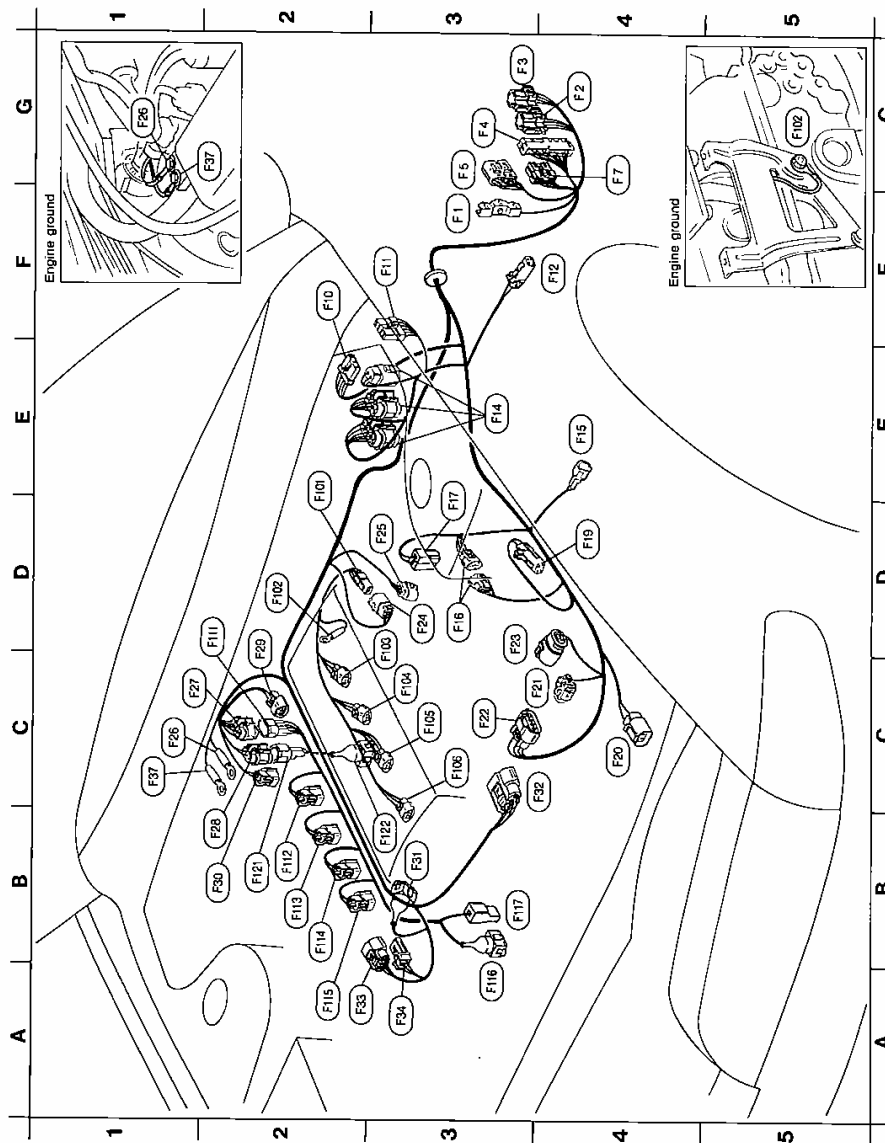

HARNES LAYOUT

Engine Control Harness (Cont'd)

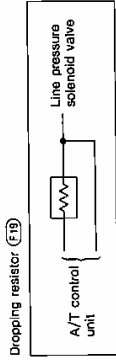

- Sub-harness**
- D2 (F10) : To (F24)
 - D2 (F10) : Engine ground
 - C3 (F10) : Ignition coil No.4
 - C3 (F10) : Ignition coil No.3
 - C3 (F10) : Ignition coil No.2
 - C3 (F10) : Ignition coil No.1
 - D2 (F11) : To (F27)
 - B2 (F12) : Injector No.4
 - B2 (F13) : Injector No.3
 - B2 (F14) : Injector No.2
 - A2 (F15) : Injector No.1
 - A3 (F16) : Engine coolant temperature sensor
 - B3 (F17) : Thermal transmitter
 - B2 (F18) : To (F28)
 - B3 (F22) : Knock sensor

- F3 (F1) : ECM (ECOS control module)
- G4 (F2) : ECOS relay
- G3 (F3) : Ignition coil relay
- G3 (F4) : To (M8)
- G3 (F5) : To (B53) (Model with ABS)
- G4 (F7) : To (M82) (A/T models)
- F2 (F10) : Front wiper motor
- F3 (F11) : Front wiper amplifier
- F4 (F12) : Side turn signal lamp LH
- E3 (F14) : ABS actuator (For ABS)
- E4 (F16) : Front wheel sensor LH (For ABS)
- D3 (F18) : Power transistor unit
- D3 (F17) : Wastegate valve control solenoid valve
- D4 (F19) : Dropping resistor (A/T models)
- C4 (F20) : To (E56)
- C3 (F21) : Compressor
- C3 (F22) : Mass air flow sensor
- D3 (F23) : Power steering oil pressure switch
- D3 (F24) : To (F10)
- D3 (F25) : Heated oxygen sensor
- C1 (F26) : Engine ground
- C1 (F27) : To (F11)
- B2 (F28) : To (F21)
- C2 (F29) : IACV-FICD solenoid valve
- B2 (F30) : IACV-AAC valve
- B3 (F31) : VTC solenoid valve
- C4 (F32) : Camshaft position sensor
- A2 (F33) : Throttle position sensor (Brown)
- A3 (F34) : Throttle position switch (Grey) (A/T models)
- C1 (F37) : Engine ground

EL

HARNES LAYOUT

Body Harness

LHD MODELS

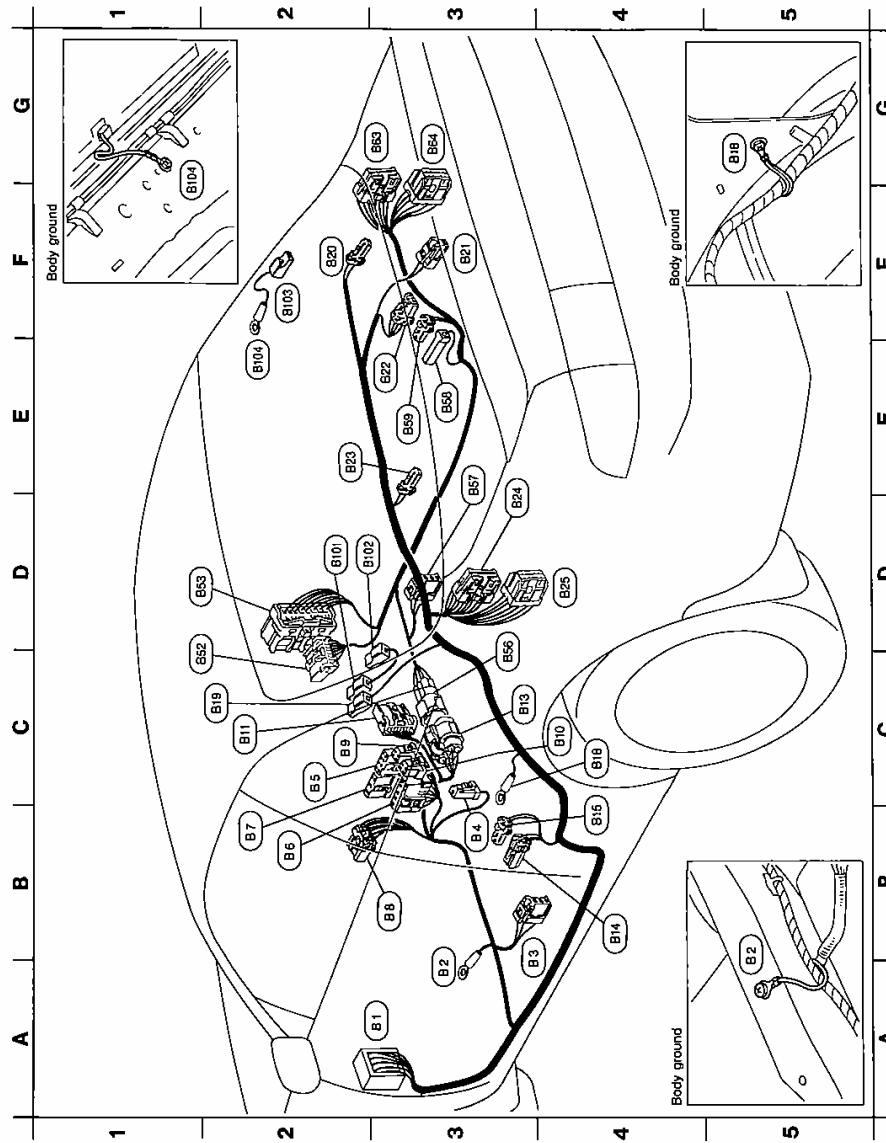

EL-96

HEL215

HARNES LAYOUT

Body Harness (Cont'd)

A3	(81)	To (M1)
A3	(82)	: Body ground
B3	(83)	: Heated seat LH
B3	(84)	: Parking brake switch
C2	(85)	: Headlamp aiming switch
B2	(86)	: Door mirror control switch
B2	(87)	: Front fog lamp switch
B3	(88)	: Overdrive switch - A/T illumination
C2	(89)	: Heated seat switch RH
C4	(90)	: Heated seat switch LH
C2	(91)	To (Z2)
C3	(92)	To (85B)
B4	(93)	: Door switch (Driver's side)
B4	(94)	: Seat belt pre-tensioner (Driver's side)
C4	(95)	: Body ground
C2	(96)	: Condenser (For rear window defogger)
F2	(97)	: Rear speaker RH
F3	(98)	: Trunk room lamp
E3	(99)	: Rear wiper motor
E2	(100)	: Rear speaker LH
D3	(101)	To (L1)
D4	(102)	To (T2)
C2	(103)	To (M8)
D2	(104)	To (E2)
C3	(105)	To (813)
E3	(106)	: Heated seat RH
E3	(107)	: Door switch (Passenger side)
E3	(108)	: Seat belt pre-tensioner (Passenger side)
G3	(109)	To (T2)
G3	(110)	To (T2)

Sub-harness

D2	(109)	: Condenser (For rear window defogger)
F2	(109)	: Rear window defogger (+)
F2	(110)	: Rear window defogger (-)
E2	(110)	: Body ground



HARNES LAYOUT

Body Harness (Cont'd)

RHD MODELS

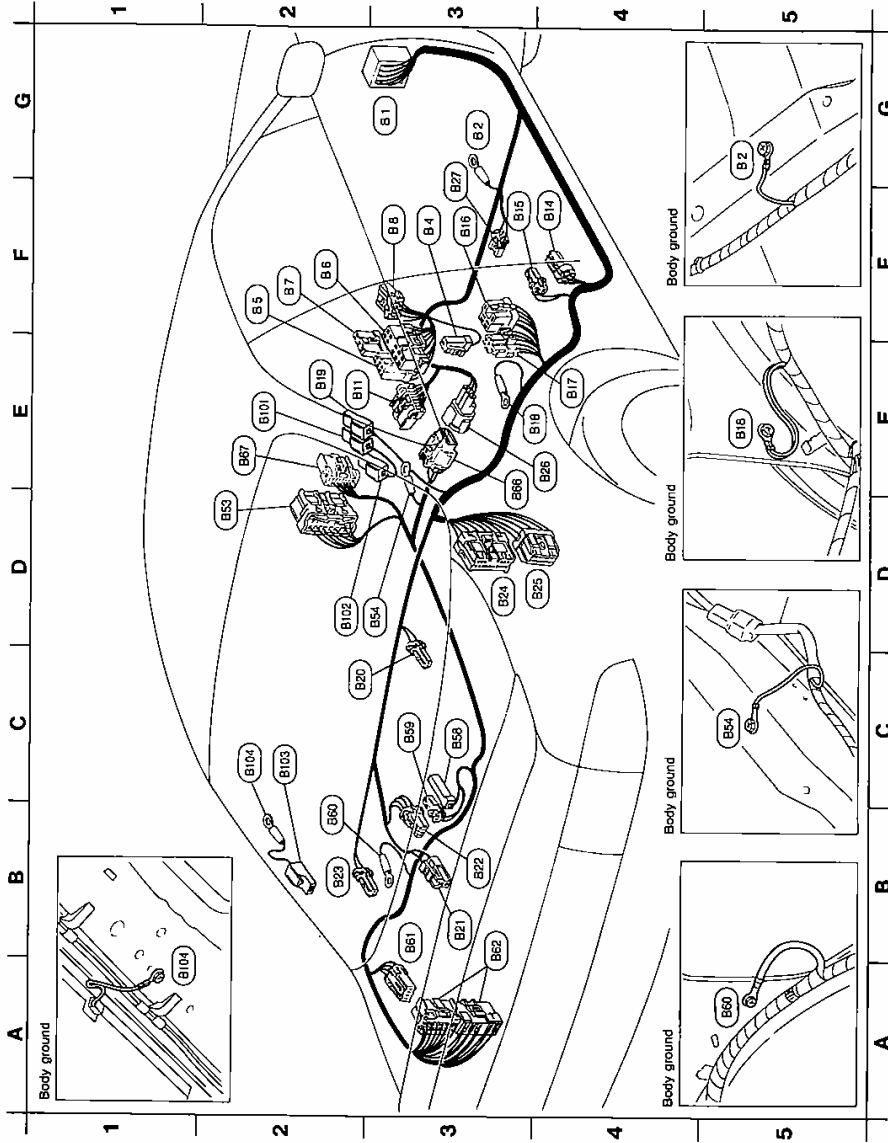

HARNES LAYOUT

Body Harness (Cont'd)

- Sub-harnesses
- E2 (810) : Condenser (For rear window defogger)
 - D2 (810) : Rear window defogger (+)
 - C2 (810) : Rear window defogger (-)
 - C2 (810) : Body ground
- G3 (81) : To (X11)
 - G3 (82) : Body ground
 - F3 (84) : Parking brake switch
 - F2 (85) : Headlamp aiming switch (For Europe)
 - F2 (86) : Door mirror control switch
 - F2 (87) : Front fog lamp switch (For Europe)
 - F3 (88) : Overdrive switch • A/T illumination
 - E2 (811) : To (Z2)
 - F4 (814) : Door switch (Driver's side)
 - F3 (815) : Seat belt pre-tensioner (Driver's side) (For Europe)
 - F3 (816) : Multi-remote control relay-1 (Except for Europe)
 - E4 (817) : Multi-remote control relay-2 (Except for Europe)
 - E3 (818) : Body ground
 - E2 (819) : Condenser (For rear window defogger)
 - C2 (820) : Rear speaker RH
 - B3 (821) : Trunk room lamp
 - B3 (822) : Rear wiper motor (Except for Australia)
 - B2 (823) : Rear speaker LH
 - D3 (824) : To (T1)
 - D4 (825) : To (T2)
 - E4 (826) : To (826)
 - G3 (827) : Seat belt switch (For Australia)
 - D2 (853) : To (F5) (Models with ABS)
 - D3 (854) : Body ground
 - C3 (858) : Door switch (Passenger side)
 - C3 (859) : Seat belt pre-tensioner (Passenger side) (For Europe)
 - B2 (860) : Body ground (Models with ABS)
 - B3 (861) : To (T2) (Models with ABS)
 - B3 (862) : ABS control unit (For ABS)
 - E3 (866) : To (836)
 - E2 (867) : To (867) (Models with ABS)



HARNES LAYOUT

Door Harness (LHD models)

FRONT LH

- (D1) : To (M14)
- (D2) : To (M15)
- (D3) : Door speaker
- (D4) : Power window regulator
- (D5) : Door mirror defogger
- (D6) : Door mirror
- (D9) : Power window main switch
- (D13) : Lock knob switch

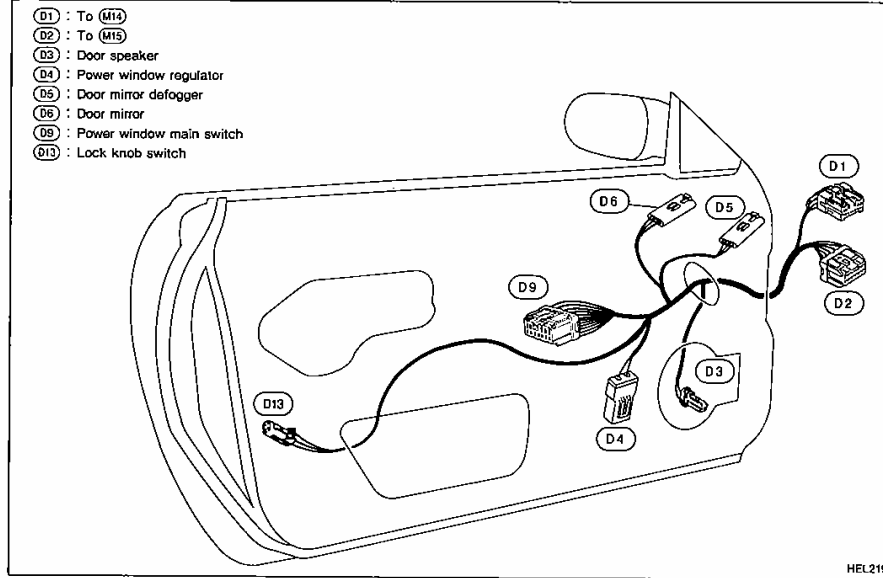

HARNESS LAYOUT

Door Harness (RHD models)

FRONT RH

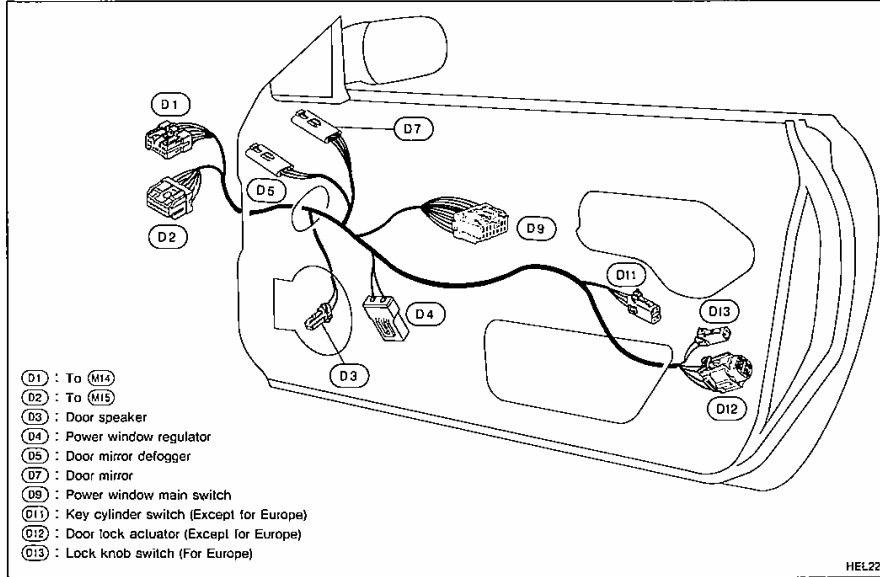

EL

HARNES LAYOUT

NOTE

EL-102

ALPHABETICAL INDEX

SECTION **IDX**

IDX

ALPHABETICAL INDEX

A

A/C circuit diagram (manual A/C) HA-2
 A/C wiring diagram (auto A/C) HA-18
 A/C wiring diagram (manual A/C) HA-3
 AT diagnosis communication line
 (Except for Europe) EC-117
 AT diagnosis communication line
 (For Europe) EC-44

B

Battery EL-15
 Baulk ring (MT) MT-3
 Boost pressure control EC-8

C

Camshaft position sensor inspection
 (Except for Europe) EC-98
 Camshaft position sensor inspection
 (For Europe) EC-23
 Combination meter EL-35
 CONSULT for ECCS EC-18
 CONSULT general information GI-5
 Cooling fan motor inspection (For
 Europe) EC-77
 Cooling fan relay inspection (For
 Europe) EC-77
 Counter gear (MT) MT-3
 Coupling sleeve (MT) MT-3

D

Data link connector for Consult (For
 Europe) EC-93
 Dual pressure switch HA-17

E

ECCS circuit diagram EC-6
 ECCS component parts location EC-2
 ECCS system diagram and chart EC-3
 ECCS trouble diagnoses (Except for
 Europe) EC-94
 ECCS trouble diagnoses (For Europe) EC-19
 ECCS trouble diagnoses EC-14
 EGR & canister control solenoid valve
 inspection (Except for Europe) EC-119
 EGR & canister control solenoid
 valve inspection (For Europe) EC-51

Electrical load signal circuit (For
 Europe) EC-91
 Electrical units location EL-82
 Engine coolant temperature sensor
 inspection (Except for Europe) EC-104
 Engine coolant temperature sensor inspection
 (For Europe) EC-29

F

Fog lamp, front EL-17
 Fog lamp, rear - See Rear fog lamp EL-19
 Front fog lamp EL-17
 Fuel gauge EL-36
 Fuel pump inspection (Except for
 Europe) EC-125
 Fuel pump inspection (For Europe) EC-61

G

Gauges EL-35
 Gears (MT) MT-3

H

Harness layout EL-84
 Hazard warning lamp EL-21
 Heated oxygen sensor heater inspec-
 tion (Except for Europe) EC-123
 Heated oxygen sensor heater inspec-
 tion (For Europe) EC-55
 How to read wiring diagrams GI-4
 How to use this manual GI-3

I

IACV - FICD solenoid valve inspec-
 tion (Except for Europe) EC-128
 IACV - FICD solenoid valve inspec-
 tion (For Europe) EC-73
 IACV-AAC valve inspection (For
 Europe) EC-70
 Ignition coil inspection (Except for
 Europe) EC-107
 Ignition coil inspection (For Europe) EC-32
 Ignition control system (Except for
 Europe) EC-107
 Ignition control system (For Europe) EC-32
 Illumination EL-27
 Injector inspection (Except for
 Europe) EC-124
 Injector inspection (For Europe) EC-58

ALPHABETICAL INDEX

Interior lamp EL-27, 33

K

Knock sensor (KS) inspection (For Europe)..... EC-39

L

Location of electrical units..... EL-82

M

Main drive gear (MT) MT-3
 Mainshaft (MT)..... MT-3
 Malfunction indicator lamp (MIL) (For Europe)..... EC-93
 Mass air flow sensor inspection (Except for Europe)..... EC-101
 Mass air flow sensor inspection (For Europe)..... EC-26
 Mass air flow sensor inspection EC-137
 Meter and gauges EL-35
 MIL & Data link connectors circuit (For Europe)..... EC-93
 MT overhaul..... MT-2
 Multi-remote control system EL-53

N

NATS (Nissan Anti-Theft System) EL-63
 NATS V2.0 precautions (For Europe)..... GI-2
 Neutral position switch inspection (Except for Europe)..... EC-130
 Neutral position switch inspection (For Europe)..... EC-87

P

Power door mirror..... EL-51
 Power steering oil pressure switch inspection (For Europe)..... EC-85
 Power supply routing EL-4
 Power transistor inspection (Except for Europe) EC-107
 Power transistor inspection (For Europe)..... EC-32
 Power window..... EL-46

R

Rear fog lamp EL-19
 Rear window signal (For Europe) EC-91
 Refrigerant lines HA-24
 Reverse gear (MT) MT-3
 Reverse idler shaft (MT) MT-3

S

Self-diagnostic results EC-16
 SMJ (super multiple junction)..... Foldout
 Speedometer..... EL-36
 Spot lamp..... EL-33
 Starter EL-16
 Starting system EL-16
 Symbols and abbreviations GI-3
 Synchronizer (MT) MT-3

T

Tachometer EL-36
 Theft warning system EL-57
 Throttle position sensor inspection (Except for Europe)..... EC-114
 Throttle position sensor inspection (For Europe)..... EC-41
 Tightening torque of standard bolts..... GI-6
 Transmission case (MT)..... MT-2
 Trunk room lamp EL-33
 Turn signal lamp..... EL-21

V

Vacuum hose drawing (ECCS) EC-5
 Vehicle speed sensor (VSS) inspection (For Europe) EC-49
 VTC solenoid valve inspection (For Europe)..... EC-67

W

Warning buzzer..... EL-44
 Warning lamps..... EL-37
 Wastegate Valve Control Solenoid Valve (For Europe) EC-64
 Water temperature gauge EL-36

IDX

